

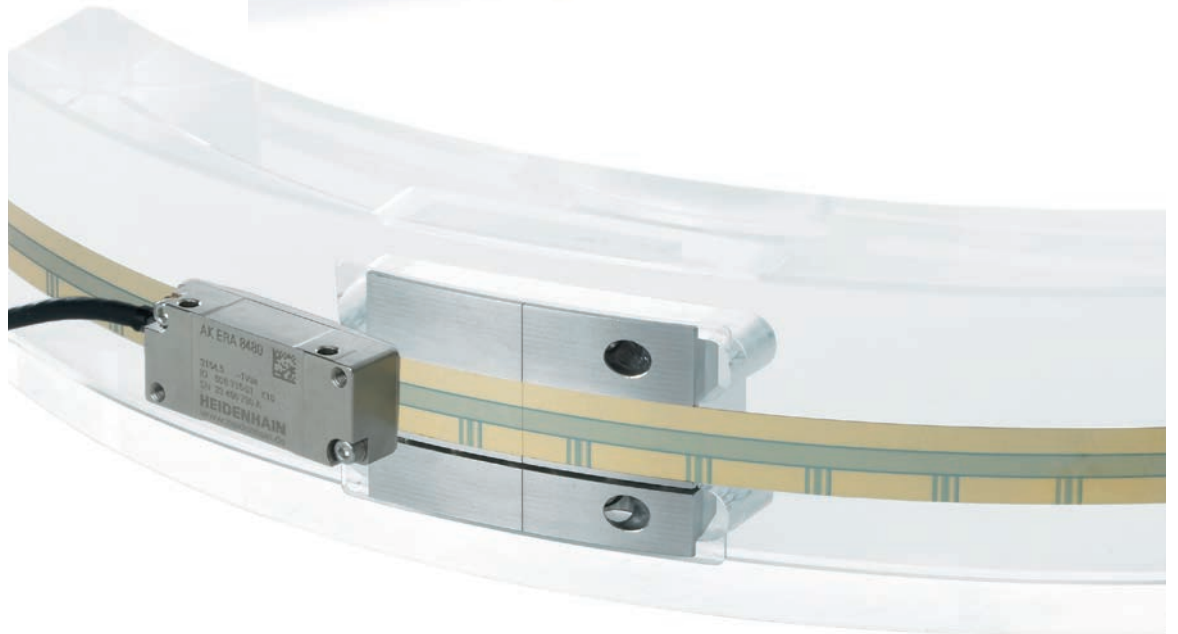

HEIDENHAIN

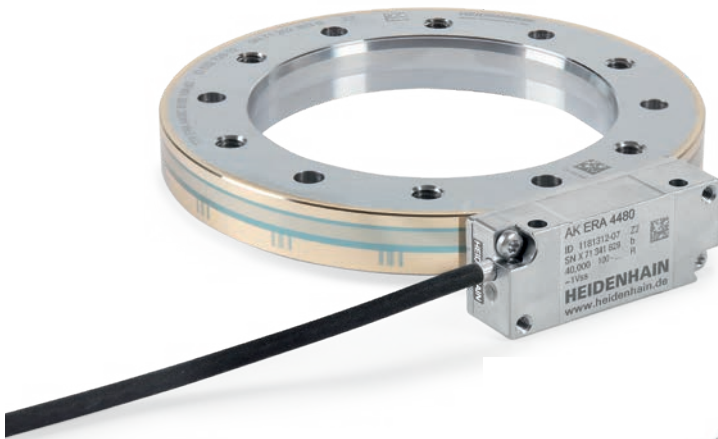

Modular Angle Encoders
with Scale Drum
or Scale Tape



Information on

- Sealed angle encoders
- Rotary encoders
- Encoders for servo drives
- Exposed linear encoders
- Linear encoders for numerically controlled machine tools
- HEIDENHAIN interface electronics
- HEIDENHAIN controls

is available upon request as well as on the Internet at www.heidenhain.com.

This brochure supersedes all previous editions, which thereby become invalid. The basis for ordering from HEIDENHAIN is always the brochure edition valid when the order is placed.

Standards (ISO, EN, etc.) apply only where explicitly stated in the brochure.



Further information:

For comprehensive descriptions of all available interfaces, as well as general electrical information, please refer to the *Interfaces of HEIDENHAIN Encoders* brochure.

Table of contents

Overview		
Angle encoders from HEIDENHAIN		4
Selection guide		6
Technical features and mounting information		
Measuring principles		12
Scanning principles		14
Measurement accuracy		16
Reliability		22
Angle encoders on direct-drive motors		24
Mechanical design types and mounting		25
General information		34
Functional safety		36
Specifications	<i>Series or model</i>	
Modular angle encoders with optical scanning and scale drum	ECA 4400 series	40
	ERA 4000 series	48
Modular angle encoders with magnetic scanning and scale drum	ECM 2400 series	58
	ERM 2000 series	64
Modular angle encoders with optical scanning and scale tape	ERA 7000 series	76
	ERA 8000 series	80
Further information		
Testing equipment and diagnostics		84

Angle encoders from HEIDENHAIN

Angle encoders are used in applications requiring angular measurement at high resolution or at accuracies of down to just a few arc seconds.

Examples:

- Rotary tables on machine tools
- Swivel heads on machine tools
- C axes on lathes
- Measuring machines for gears
- Printing units of printing machines
- Spectrometers
- Telescopes

By contrast, rotary encoders are used in applications where accuracy requirements are less stringent, including automation, electric motors and many other applications.



Angle encoders differ in terms of the following physical design characteristics:

Sealed angle encoders with a hollow shaft and stator coupling

The stator coupling is designed so that the coupling absorbs only the torque arising from bearing friction, especially during angular acceleration of the shaft. These angle encoders therefore provide excellent dynamic performance. Due to the stator coupling, the stated system accuracy includes the error of the shaft coupling.

The RCN, RON and RPN angle encoders have an integrated stator coupling, while the ECN is externally mounted.

Other benefits:

- Compact size for limited installation space
- Hollow shaft diameters of up to 100 mm
- Easy installation
- Also available with functional safety



RCN 8000 absolute angle encoder



ECA 4000 absolute angle encoder

Modular angle encoders with optical scanning

The ERP, ERO, ERA and ECA modular angle encoders are particularly well suited for high-accuracy applications with low installation space. Particular benefits:

- Wide hollow-shaft diameter (of up to 10 m with a scale tape)
- High shaft speeds of up to 20000 rpm
- No additional starting torque from shaft seals
- Segment solutions
- Also available with functional safety

Modular angle encoders with optical scanning are available with various graduation carriers:

- *ERP/ERO*: Glass circular scale with hub
- *ERA/ECA 4000*: Steel drum
- *ERA 7000/8000*: Steel scale tape

Because these angle encoders do not come with an enclosure, the required degree of protection must be ensured through proper installation.



ECM 2000 absolute angle encoder

Modular angle encoders with magnetic scanning

Thanks to their robust design, the ERM and ECM modular angle encoders are highly immune to cooling lubricant and contamination in production machines. They are ideal for medium to high accuracy requirements and low installation space:

- Large shaft diameters
- High shaft speeds of up to 60000 rpm
- No additional starting torque from shaft seals
- High immunity to contamination
- Available with functional safety

Selection guide



Modular angle encoders with optical scanning and a scale drum

Series	Overall dimensions in mm	Diameter	Accuracy of graduation	Mechanically permissible speed ¹⁾	Design
ECA 4400 ²⁾		D1: 70 mm to 512 mm D2: 104.63 mm to 560.46 mm	±3.7" to ±2"	≤ 15000 rpm ³⁾ to ≤ 2750 rpm	Steel drum with centering collar
ECA 4402			±3" to ±1.5"	≤ 15000 rpm to ≤ 2750 rpm	Steel drum with three-point centering
ERA 4x00		D1: 40 mm to 512 mm D2: 76.5 mm to 560.46 mm	±5" to ±2"	≤ 20000 rpm ³⁾ to ≤ 2750 rpm	Steel drum with centering collar
ERA 4202			±4" to ±1.7"	≤ 20000 rpm to ≤ 4750 rpm	Steel drum with three-point centering

¹⁾ May be limited during operation by the electrically permissible shaft speed

²⁾ Also available with functional safety

³⁾ Limited in the case of mechanical fault exclusion

	Signal periods/ revolution	Interface	Reference marks	Page
	–	EnDat 2.2 Fanuc Mitsubishi Panasonic Yaskawa	–	40
	3000 to 52000	\sim 1 V _{PP} 	Distance-coded or one	48
	12000 to 52000	\sim 1 V _{PP} 	Distance-coded or one	52



ECA 4000

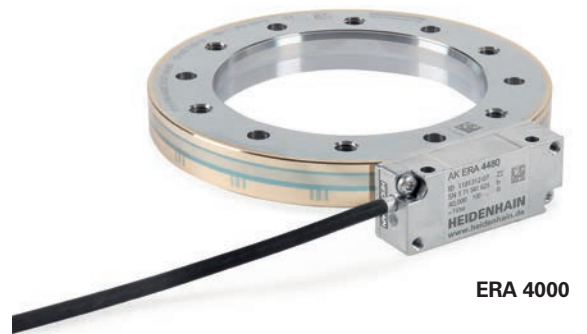

ERA 4000

Modular angle encoders with magnetic scanning and a scale drum

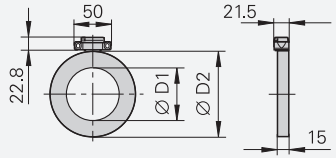
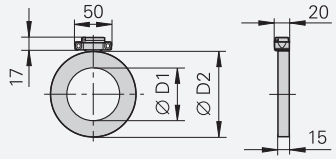
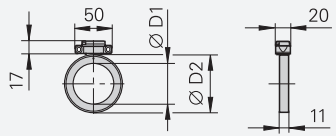
Series	Overall dimensions in mm	Diameter	Accuracy of graduation	Mechanically perm. speed	Design
ECM 2400		D1: 70 mm to 260 mm D2: 113.16 mm to 326.9 mm	$\pm 8''$ to $\pm 3.5''$	14500 rpm to 4500 rpm	Fastening via screws
ERM 2200		D1: 40 mm to 410 mm D2: 64.37 mm to 452.64 mm	$\pm 12''$ to $\pm 2.5''$	22000 rpm to 3000 rpm	Fastening via screws
ERM 2203		D1: 40 mm to 295 mm D2: 64.37 mm to 326.90 mm	$\pm 8''$ to $\pm 1.5''$	22000 rpm to 4500 rpm	
ERM 2400		D1: 40 mm to 512 mm D2: 64.37 mm to 603.52 mm	$\pm 13''$ to $\pm 3''$	22000 rpm to 1600 rpm	
ERM 2404		D1: 30 mm to 100 mm D2: 45.26 mm to 128.75 mm	$\pm 24''$ to $\pm 9''$	60000 rpm to 20 000 rpm	Friction-locked fastening through clamping of the drum
ERM 2904		D1: 35 mm to 100 mm D2: 54.43 mm to 120.96 mm	$\pm 72''$ to $\pm 33''$	50000 rpm to 16 000 rpm	
ERM 2405		D1: 40 mm; 55 mm D2: 64.37 mm; 75.44 mm	$\pm 17''$ to $\pm 14''$	33000 rpm; 27000 rpm	Friction-locked fastening through clamping of the drum; additional slot for machine key as anti- rotation element

Signal periods/revolution	Interface	Page
900 to 2600	EnDat 2.2 Fanuc Mitsubishi	58
1024 to 7200	~ 1 V _{PP}	64
1024 to 5200		66
512 to 4800	□ TTL ~ 1 V _{PP} EnDat 2.2	68
360 to 1024	~ 1 V _{PP}	70
180 to 400		70
512; 600		71

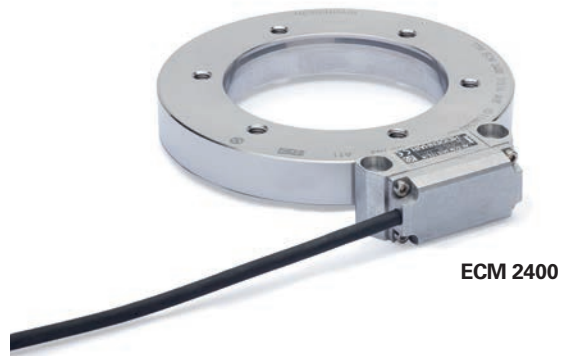

ECM 2400



ERM 2203



ERM 2404

Modular angle encoders with optical scanning and a scale tape

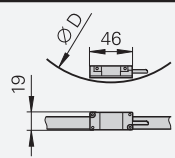
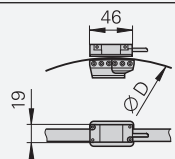
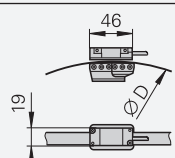
Series	Overall dimensions in mm	Diameter	Accuracy of graduation	Mechanically permissible speed ¹⁾	Design
ERA 7000		458.62 mm to max. 3000 mm upon request	±3.9" to ±0.7"	≤ 250 rpm to approx. 85 rpm	For inner mounting, full-circle and segment version ²⁾
ERA 8000		458.11 mm to max. 3000 mm upon request	±4.7" to ±0.9"	≤ 50 rpm to ≤ 15 rpm	For outer mounting, full-circle and segment version ²⁾
ERA 8900		≥ 3000 mm upon request	Upon request	Upon request	Outer mounting, very wide operating tolerances, full-circle and segment version ²⁾

¹⁾ May be limited during operation by the electrically permissible shaft speed

²⁾ Segment solutions upon request

Signal periods/ revolution	Interface	Reference marks	Page
36000 to ≈ 230 000	~ 1 V _{PP}	Distance-coded	76
36000 to ≈ 230 000	~ 1 V _{PP}	Distance-coded	80
Upon request	~ 1 V _{PP}	Distance-coded	Upon request



ERA 7000

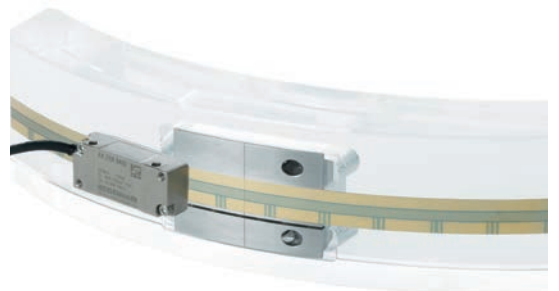

ERA 8000

Measuring principles

Measuring standard

HEIDENHAIN encoders use measuring standards consisting of periodic structures known as graduations. The optical graduations are applied to a glass or steel carrier substrate. For encoders with large measuring lengths, the graduation carrier is a steel tape.

HEIDENHAIN manufactures the precision graduations in the following specially developed, photolithographic processes:

- METALLUR: contamination-tolerant graduation consisting of metal lines on gold; typical grating period: 20 μm
- SUPRADUR phase grating: optically three-dimensional, planar structure; particularly tolerant to contamination; typical grating period: 8 μm and finer
- OPTODUR phase grating: optically three-dimensional, planar structure with particularly high reflectance; typical grating period: 2 μm and finer
- TITANID phase grating: exceptionally robust, optically three-dimensional structure with a high degree of reflectance; typical grating period: 8 μm

Along with the very fine grating periods, these processes permit high edge definition and excellent homogeneity of the graduation. In combination with the photoelectric scanning method, these characteristics are critical for attaining high-quality output signals.

Magnetic encoders use a graduation carrier made of a magnetizable steel alloy. A write head creates strong local magnetic fields in different directions, resulting in a graduation consisting of magnetically north and south poles (MAGNODUR procedure). In combination with the magnetoresistive scanning method, this technology delivers a measuring method that is robust despite environmental factors.

Absolute measuring method

In the absolute measuring method, the position value is available immediately upon encoder switch-on and can be requested by the downstream electronics at any time. There is no need to move the axes to find the reference position. Instead, the absolute position information is read **from the graduation on the measuring standard**, which is designed as a serial absolute code structure. To obtain the position value, a separate incremental track is interpolated.



Graduation of absolute angle encoders

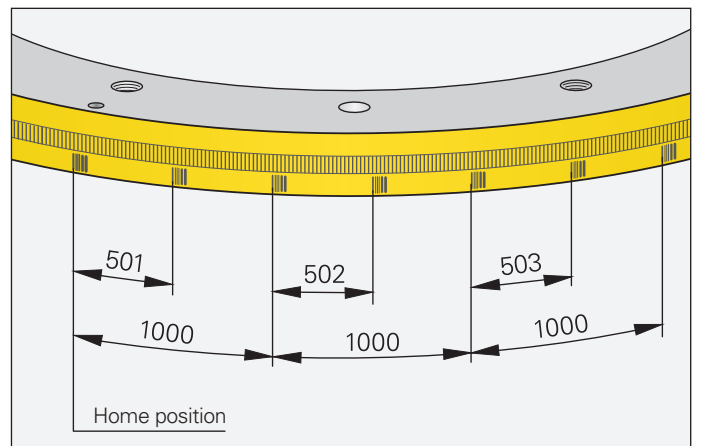

Schematic representation of a circular graduation with distance-coded reference marks (example for ERA 4480 with 20000 lines)

Incremental measuring method

In the **incremental measuring method**, the graduation is a periodic grating structure. The position information is obtained **through counting** the individual increments (measuring steps) starting at a freely selectable point of origin. Since position measurement requires an absolute point of reference, the measuring standard features an additional track containing a **reference mark**. The absolute position on the scale, established by the reference mark, is gated with exactly one measuring step.

The reference mark must therefore be traversed before an absolute point of reference can be established or before the most recently selected reference point is refound.

In some cases, this may require rotation by up to nearly 360°. To simplify these reference runs, many HEIDENHAIN encoders feature **distance-coded reference marks**: the reference-mark track contains multiple reference marks at different defined intervals. The downstream electronics determine the absolute reference point after just two neighboring reference marks have been traversed; in other words, after just a few degrees of rotational motion (see "Nominal increment N" in the table). Encoders with distance-coded reference marks are identified with a "C" after the model designation (e.g., TTR ERA 4200C).

Graduation drum: TTR ERA 4000C

Number of signal periods based on graduation period			Number of reference marks	Nominal increment N
20 µm	40 µm	80 µm		
–	–	3 000	6	120°
8 192	4 096	4 096	8	90°
–	–	5 000	10	72°
12 000	6 000	–	12	60°
–	–	7 000	14	51.429°
16 384	8 192	8 192	16	45°
20 000	10 000	10 000	20	36°
24 000	12 000	12 000	24	30°
–	–	13 000	26	27.692°
28 000	14 000	–	28	25.714°
32 768	16 384	–	32	22.5°
40 000	20 000	–	40	18°
48 000	24 000	–	48	15°
52 000	26 000	–	52	13.846°
–	38 000	–	76	9.474°
–	44 000	–	88	8.182°

Graduation drum: TTR ERM 2200C

Number of signal periods	Number of reference marks	Nominal increment N
1024	16	45°
1200	24	30°
1440	30	24°
1800	36	20°
2048	32	22.5°
2400	40	18°
2800	50	14.4°
3392	32	22.50°
4096	64	11.25°
5200	52	13.85°
7200	90	8°

Scale tape: MSB ERA 7480 C, MSB ERA 8480 C

Number of signal periods	Number of reference marks	Nominal increment N
36 000	72	10°
45 000	90	8°
90 000	180	4°

Graduation drum: TTR ERM 2400C

Number of signal periods	Number of reference marks	Nominal increment N
512	16	45°
600	20	36°
720	24	30°
900	30	24°
1024	32	22.5°
1200	30	24°
1400	40	18°
1696	32	22.5°
2048	32	22.5°
2600	52	13.85°
3600	60	12°
3850	70	10.3°
4800	80	9°

Scanning principles

HEIDENHAIN encoders employ different measuring principles. All of these principles involve detecting exceedingly fine graduation lines on a carrier material and generating output signals as a result. The specific characteristics of the scanning principle affect data collection in the target application and should therefore be properly matched.

HEIDENHAIN uses two scanning principles for scale-drum and scale-tape modular angle encoders:

- Optical scanning for the ECA and ERA
- Magnetic scanning for the ECM and ERM

Optical scanning

Put simply, the imaging scanning principle uses projected-light signal generation: two gratings with equal or similar grating periods are moved relative to each other. These are the scale and the scanning reticle. The carrier material of the scanning reticle is transparent. The measuring standard's graduation can be applied to transparent or reflective material.

Parallel light passes through a grating structure, casting dark and light fields at a certain distance, where there is an index grating with the same or similar grating period. When the two gratings move relative to each other, the incident light is modulated: If the gaps are aligned, light passes through. If the lines of one grating coincide with the gaps of the other, no light passes through. Photocells convert these light fluctuations into electrical signals. The specially structured grating of the scanning reticle filters the light so as to generate nearly sinusoidal output signals. The smaller the graduation period of the grating structure, the closer and more tightly tolerated the gap must be between the scanning reticle and the scale. In encoders that use the imaging scanning principle, workable mounting tolerances are attainable starting at a minimum grating period of 10 μm .

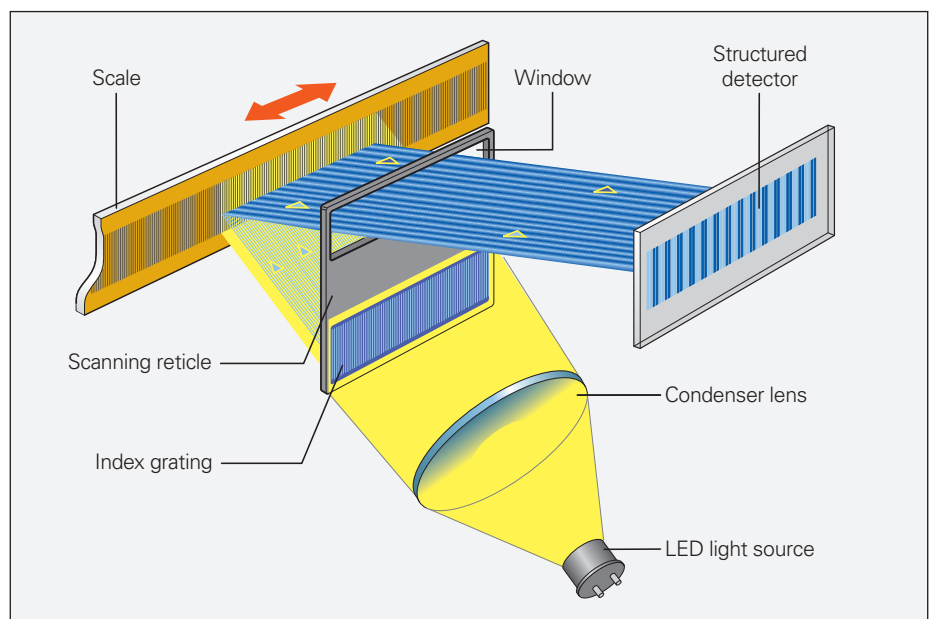

Photoelectric scanning in accordance with the imaging principle and single-field scanning

Magnetic scanning

The permanent-magnet MAGNODUR graduation is scanned by magnetoresistive sensors. They consist of resistive tracks whose resistance values change in response to a magnetic field. When voltage is applied to the sensor, and when there is relative motion between the scanning head and the scale drum, the current is modulated in accordance with the magnetic field.

The special geometric configuration of the resistive sensors, combined with the manufacturing process used for the scanning PCBs on glass substrates, ensures high signal quality. In addition, the large scanning surface enables filtering of the signal harmonics. Such are the requirements for low position error within a signal period.

The graduation periods are at approx. 200 μm to 1000 μm . For this reason, devices with magnetoresistive scanning are used in applications with mid-level accuracy requirements.

Encoders with MAGNODUR scanning are highly immune to contamination and are well suited for use at higher operating temperatures.

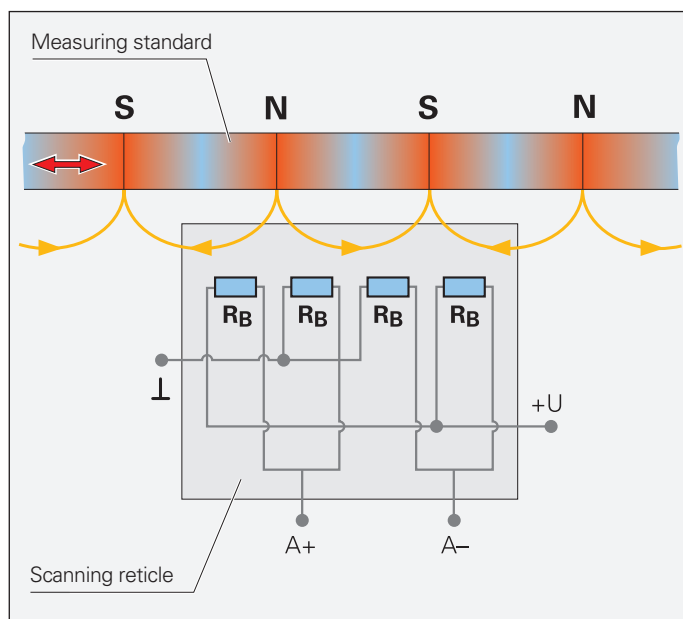

Magnetoresistive scanning principle

Measurement accuracy

Encoder-specific error

The accuracy of angular measurement is mainly determined by:

- The quality of the graduation
- The stability of the graduation carrier
- The scanning quality
- The quality of the signal processing electronics
- The eccentricity of the graduation relative to the bearing
- The bearing error
- The coupling to the measured shaft

These factors can be divided into encoder-specific error and application-dependent factors. For assessment of the attainable **overall accuracy**, all of these individual factors must be taken into account.

Encoder-specific error

The encoder-specific error includes:

- The graduation accuracy
- The interpolation accuracy
- The position noise

The graduation accuracy

The graduation accuracy results from the quality of the graduation. It includes:

- Homogeneity and period definition of the graduation
- The alignment of the graduation on the graduation carrier
- *For encoders with solid graduation carriers:* the stability of the graduation carrier, ensuring accuracy even after mounting
- *For encoders with a steel scale tape:* the error due to irregular scale-tape expansion during mounting, as well as the error at the scale-tape butt joints in full-circle applications

The accuracy of the graduation is the **baseline error**. This accuracy is ascertained under ideal conditions via measurement of the position error by means of a serially produced scanning head. The distance between the measuring points is equivalent to the integer multiple of the signal period. As a result, the interpolation error has no effect.

For modular angle encoders, the graduation accuracy is stated in accuracy grades for easier differentiation. Accuracy grade *a* defines the upper limit of the baseline error within the measuring range.

Accuracy of the interpolation

The interpolation error has an effect even at very low traversing speeds and causes speed fluctuations, especially in the speed control loop. Within the application, the interpolation error affects the machining quality, such as the surface quality.

The accuracy of the interpolation is primarily influenced by:

- The fineness of the signal period
- The homogeneity and period definition of the graduation
- The quality of scanning filter structures
- The characteristics of the sensors
- The quality of the signal processing electronics

These factors are taken into account in the stated interpolation error within one signal period.

The interpolation accuracy is stated in the form of a maximum value u of the interpolation error. For specific values, see the technical data.

Position noise

Position noise causes small, random deviations from the expected position. Position noise is also dependent on signal processing. Typically, the position noise is less than 1‰ of the signal period.

Static hysteresis during magnetic scanning

Whenever there is a change in direction, there is also the effect of hysteresis. This hysteresis depends on the size of the signal period and on the mounting conditions. HEIDENHAIN therefore recommends measuring this constant value in order to compensate for it. The ERM 2203 series encoders do not exhibit any hysteresis.

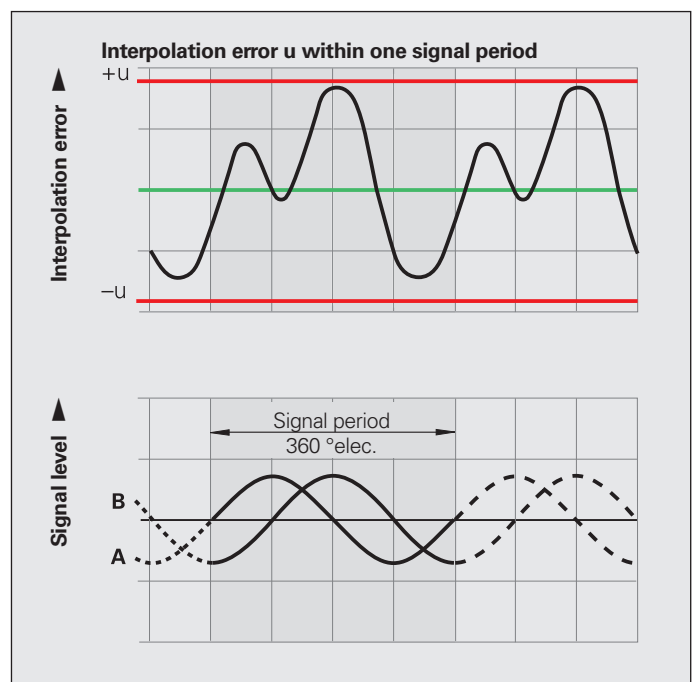
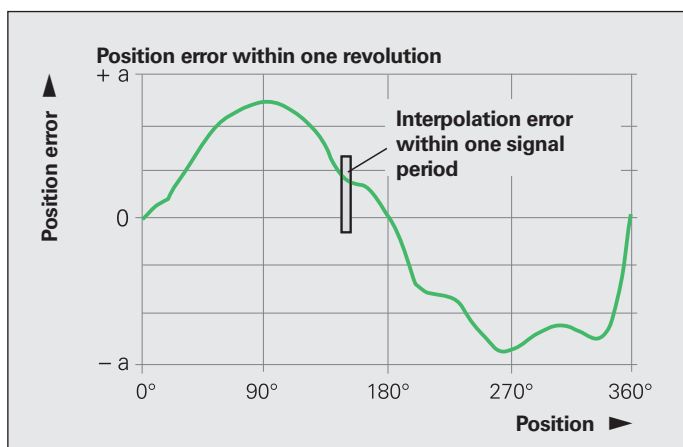

Application-dependent error

The quality of the mounting and adjustment of the scanning head, in addition to the given encoder-specific error, normally has a significant effect on the accuracy that can be achieved by **encoders without integral bearings**. Of particular importance are the mounting eccentricity of the graduation and the radial runout of the measured shaft. The application-dependent error values must be measured and calculated individually in order to evaluate the overall accuracy.

In contrast, the specified system accuracy for encoders with integral bearing already includes the error of the bearing and the shaft coupling (see the *Angle Encoders with Integral Bearing* brochure).

Error due to eccentricity of the graduation relative to the bearing

Mounting-related eccentricity between the graduation and the bearing can be expected during mounting of the disk/hub assembly, the scale drum or the steel scale tape. Dimensional and geometric errors exhibited by the mating shaft can also add to the eccentricity. The following relationship exists between the eccentricity e , the diameter of the graduation D and the measurement error $\Delta\varphi$ (see bottom left figure):

$$\Delta\varphi = \pm 412 \cdot \frac{e}{D}$$

$\Delta\varphi$ = Measurement error in " (arc seconds)

e = Eccentricity of the scale drum relative to the bearing in μm (1/2 radial runout)

D = Mean graduation diameter in mm

M = Center of graduation

φ = "True" angle

φ' = Scanned angle

Calculation example:

ECA 4000 angle encoder with a drum outside diameter of 208.89 mm, radial runout of the scale drum $2\ \mu\text{m}$ ($\hat{=}$ eccentricity of $1\ \mu\text{m}$)

$$\Delta\varphi = \pm 412 \cdot \frac{1}{208.89} \approx \pm 2.0''$$

Alternative: Use the graph at the bottom right

Mean graduation diameter D for:

ERA 4000 ECA 4000 ERM 2000 ECM 2000	$D \hat{=}$ Drum outside diameter
ERA 7000 ERA 8000	$D \hat{=}$ Scale mating diameter

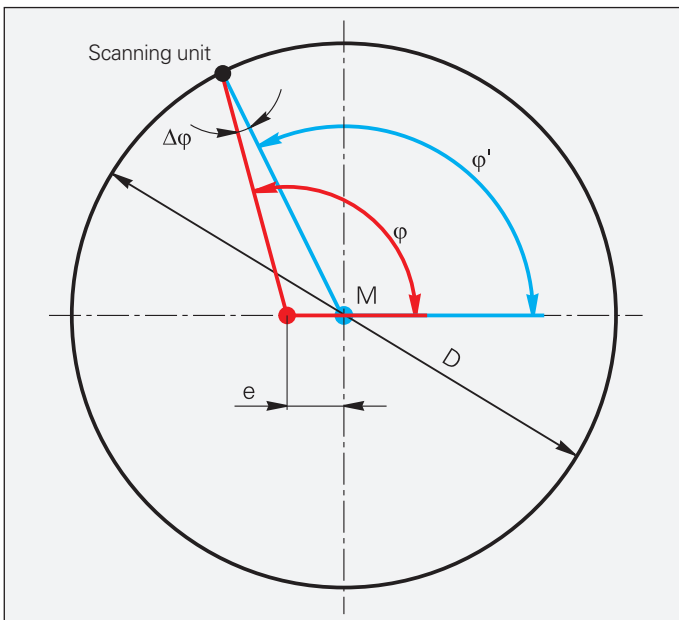

Eccentricity of the graduation relative to the bearing

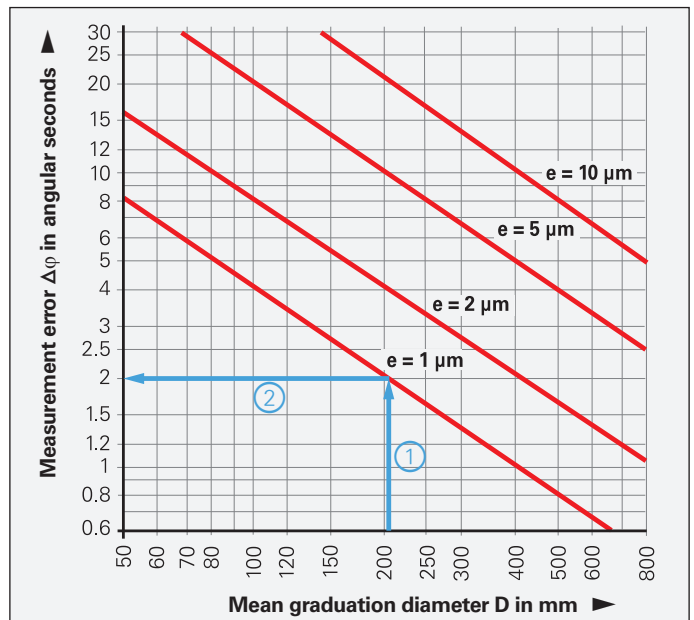

Resulting measurement error $\Delta\varphi$ for various eccentricities e as a function of the mean graduation diameter D (with graph-reading example)

Radial runout error of the bearing

The function for finding the measurement error $\Delta\varphi$ also applies to the radial runout error of the bearing when the eccentricity (half of the displayed radial runout error) is entered for e . The mechanical compliance of the bearing under radial shaft loads causes similar errors.

Deformation of the graduation resulting from mounting

Characteristics of the scale drums, such as their cross section, reference surfaces, screw holes and the position of the graduation relative to the mounting surface, are designed such that the accuracy of the encoders is only marginally affected by mounting and operation.

Geometric and diameter errors of the bearing surface (for ERA 7000 and ERA 8000)

Geometric errors of the bearing surface can affect the attainable system accuracy.

The segment solutions exhibit additional angular error $\Delta\varphi$ if the nominal scale-tape diameter is not precisely complied with:

$$\Delta\varphi = (1 - D'/D) \cdot \varphi \cdot 3600$$

With

$\Delta\varphi$ = Error for segment in arc seconds

φ = Segment angle in degrees

D = Nominal scale-tape carrier diameter

D' = Actual scale-tape carrier diameter

This error can be eliminated if the signal period per $360^\circ z'$ that is valid for the actual scale-tape carrier diameter D' can be entered into the controller. The following relationship is valid:

$$z' = z \cdot D'/D$$

With

z = Nominal signal period per 360°

z' = Actual signal period per 360°

The angle actually traversed in segment solutions should be measured with a comparative encoder, such as an angle encoder with an integral bearing.

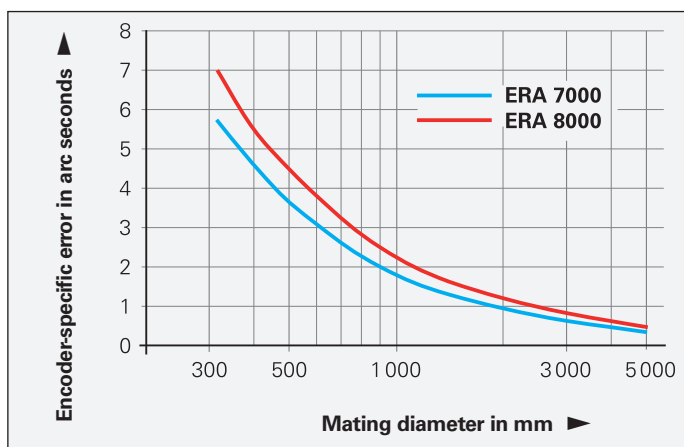

Encoder-specific error with ERA 7000 and ERA 8000

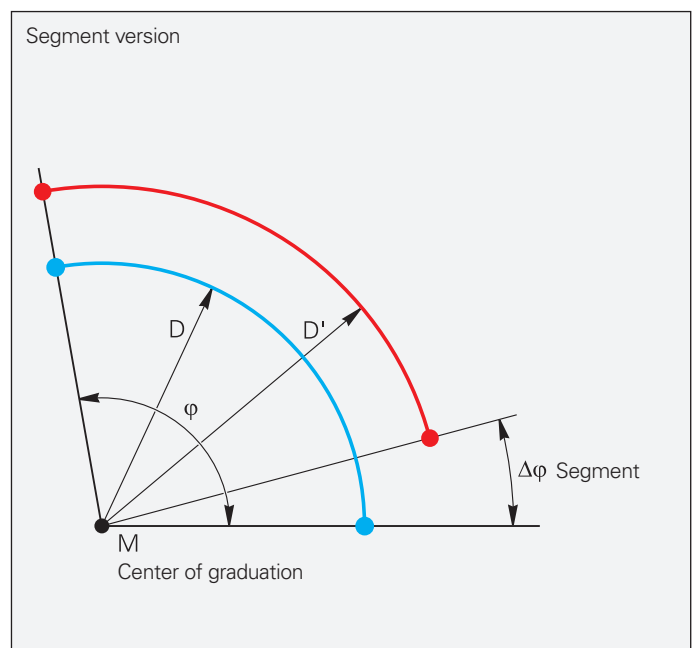

Angular error resulting from variations in the scale-tape carrier diameter

Calibration chart

All modular angle encoders from HEIDENHAIN are inspected for proper functioning prior to shipping and for accuracy during final acceptance. For the ECA 4000, ERA 4000, ECM 2400 and ERM 2203, HEIDENHAIN prepares quality inspection documents and includes them with the scale drums.

The **quality inspection document** confirms the stated **graduation accuracy** of each scale drum and documents measurement parameters along with the measurement uncertainty. The **calibration standards** ensure the traceability, as required by EN ISO 9001, to recognized national or international standards.

The graduation accuracy is determined when a single revolution is traversed, resulting in the display of a measurement curve and the value of the maximum error. The mounting-specific error is not included, nor is **interpolation error** within one signal period, which is a characteristic of the scanning head.

Temperature range

The angle encoders are inspected at a **reference temperature** of 22 °C. This is the temperature at which the system accuracy provided in the calibration chart is valid.

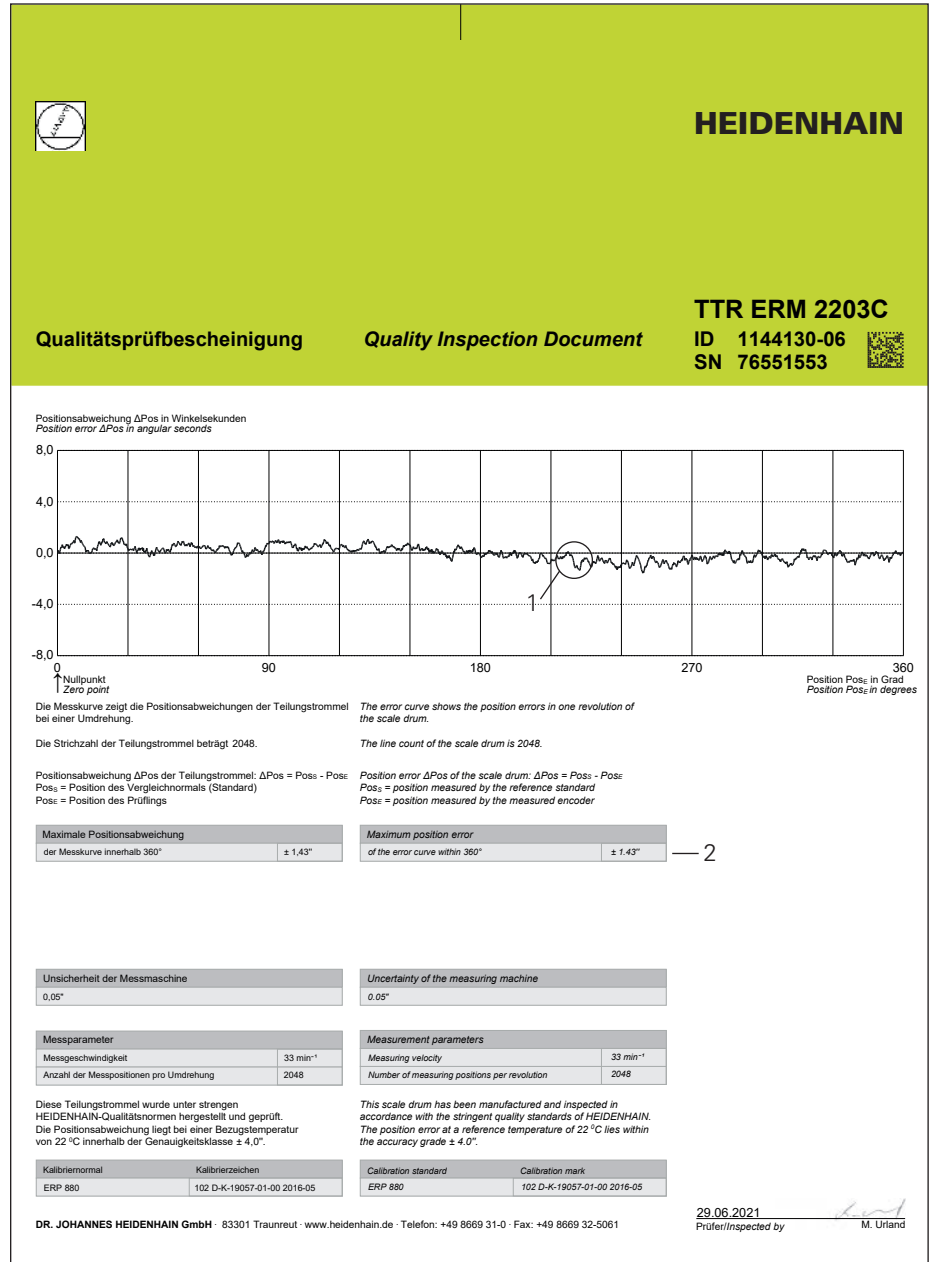

Sample calibration chart for an ERM 2203C scale drum

- 1 Graphical depiction of the graduation accuracy
- 2 Calibration result

Compensation possibilities

Reasons for compensation

For modular angle encoders, the stated encoder-specific error is based on ideal mounting. In the real-world application, however, the attainable overall accuracy of the rotary axis is affected by mounting errors in the scale drum or scanning head, and by the guideway accuracy of the bearing under different loads. Within the overall very high accuracy of modular angle encoders from HEIDENHAIN, these external errors make up most of the error. In some cases, it is therefore necessary to perform accuracy compensation for the rotary axis in order to meet requirements.

This can be done via two different methods:

- **Dynamic compensation:** This method enables the continuous, dynamic compensation of certain error components of the overall angular error during operation. It is particularly well suited for sources of error that change over time or under varying loads.
- **Static compensation:** This method allows the angular error to be compensated for at a certain point in time and during a certain operating state. It is especially well suited for constant errors.

Dynamic compensation

Aids	Compensatable causes for angular error
Two scanning heads	Centering error during mounting
	Radial runout error caused by bearing error
	Load-dependent radial runout error of the bearing
More than two scanning heads	In addition: graduation errors
	For scale-tape systems; in addition, runout errors of the scale-tape slot

Static compensation

Aids	Compensatable causes for angular error
Comparator system (ISO 230-2) or virtual reference	Centering error during mounting
Comparator system (ISO 230-2)	Graduation error of the encoder → Recommended for scale-tape encoders

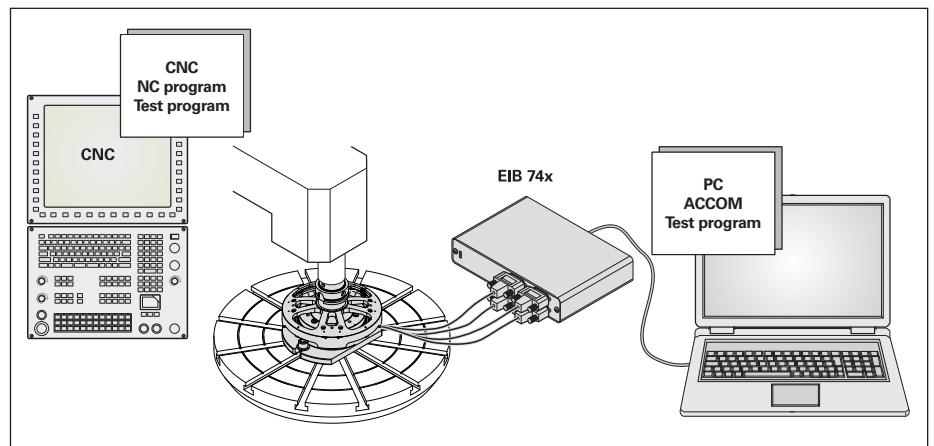

Compensation via comparator system (e.g., RVM 4000)

The following conditions are required for **dynamic compensation**:

- Two scanning heads that are mounted opposite each other.
- The possibility of calculating the positions of the scanning heads in real time. For the ERA and ERM incremental encoders, HEIDENHAIN offers the EIB 15xx. For position calculation with the ECA and ECM encoders, the controller manufacturers provide solutions integrated directly into the controller software.
- For scale-tape encoders with very wide diameters, such as those used in telescopes, four or more scanning heads are often used. In this case, position calculation occurs individually in accordance with the use case and the configuration of the scanning heads.

Good **static compensation** requires a suitable standard for comparison. There are two general approaches:

- Use of an additional calibrated encoder with higher accuracy and higher reproducibility (e.g., RVM 4000) and calibration of the rotary axis in accordance with ISO 230-2. The calculated compensation values are then stored in the controller.
- Use of a virtual reference based on the encoder to be calibrated, aided by an additional scanning head, an appropriate evaluation unit (e.g., the PWM 21) and a software application from HEIDENHAIN. The compensation values can be stored directly in the scanning head. This method is available only for selected HEIDENHAIN encoders. This is beneficial, for example, if compensation is to occur at the component level and not in a fully assembled machine.

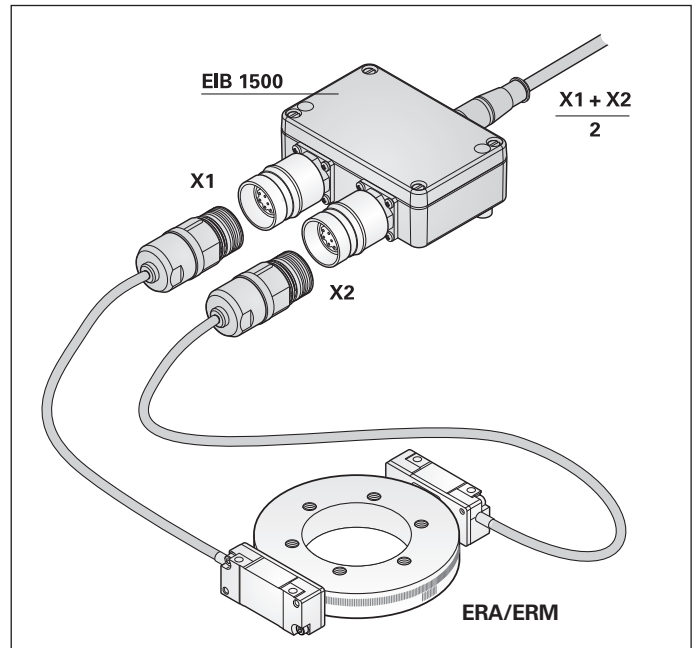

Compensation via position calculation (e.g., the EIB 1500)

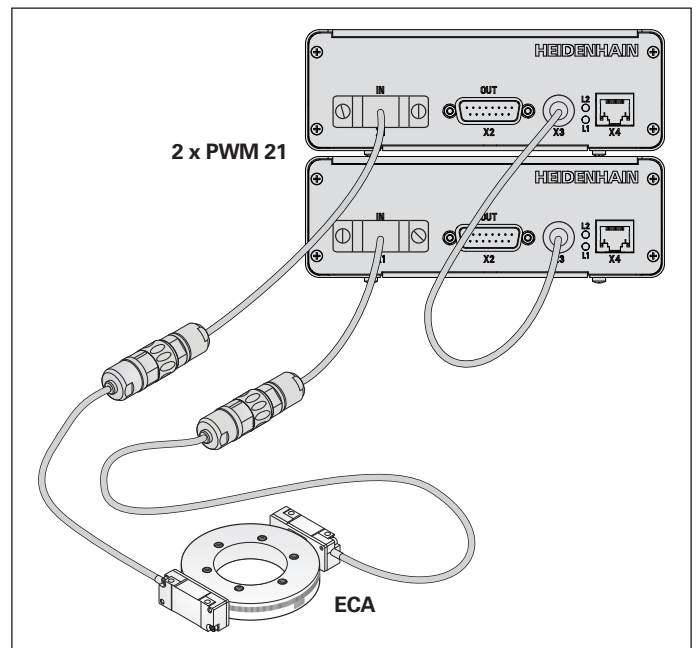

Compensation via a virtual reference with the PWM 21

Reliability

The modular angle encoders from HEIDENHAIN are optimized for use in fast and precise machines. Even with their exposed mechanical design, these encoders are highly immune to contamination, ensure high long-term stability and are fast and easy to mount.

Low sensitivity to contamination

Both the high quality of the grating and the scanning method are responsible for the accuracy and reliability of the encoders. These optical encoders from HEIDENHAIN use **single-field scanning**, by which only one scanning field is used to generate the scanning signals. Local contamination on the measuring standard (e.g., fingerprints or oil residue) influence both the light intensity of the signal components and the quality of the scanning signals. The output signals thereby change in amplitude but not with regard to the offset and phase position. They remain highly interpolable, and the interpolation error within one signal period remains low.

The **large scanning field** further reduces the sensitivity to contamination. Depending on the nature of the contamination, this feature can even prevent encoder failure. The encoders continue to provide high-quality signals even if the contamination comes from printer's ink, PCB dust, water or oil and is up to 3 mm in diameter. The interpolation error within one revolution remains far below the specified accuracy.

The figures at right show the results of contamination tests with the ERA 4000. The maximum interpolation errors within one signal period $|u|$ are shown. Despite significant contamination, the specified value of $\pm 1\%$ is only minimally exceeded.

Magnetic encoders from HEIDENHAIN are fully immune to this contamination test. The measurement signal remains unaffected even under continuous and surrounding contamination. However, metal chips, for example, must be kept out of the cooling lubricant because they could physically damage the cover sheet of the scanning head.

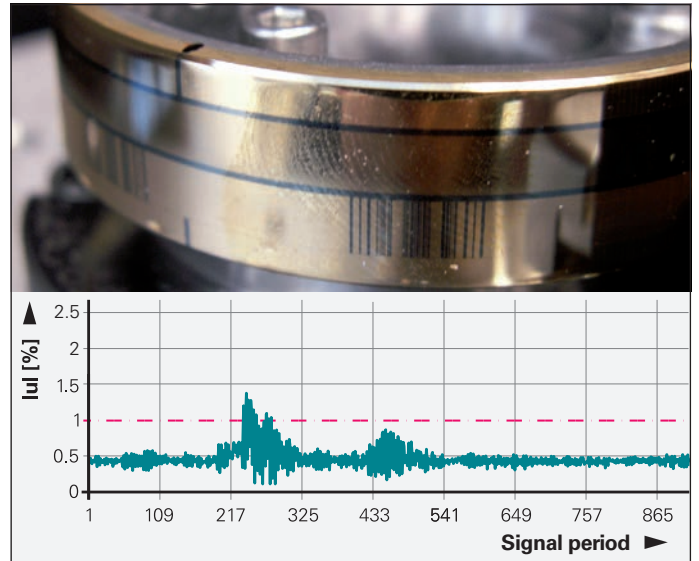

Fingerprint contamination

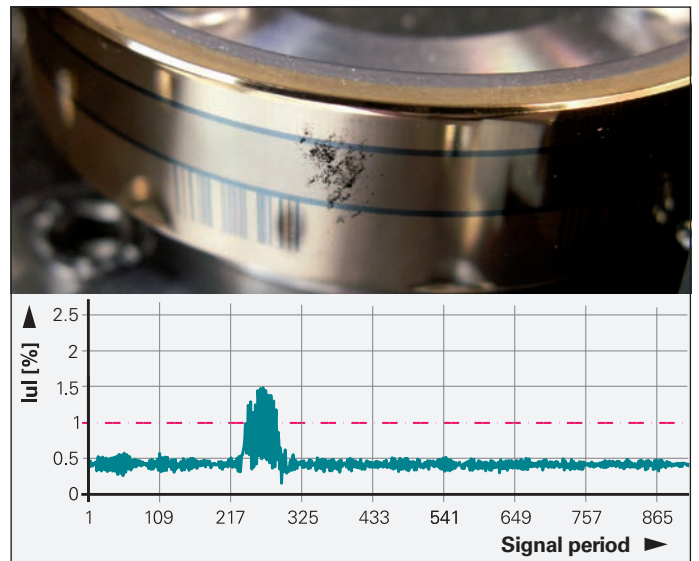

Toner dust contamination

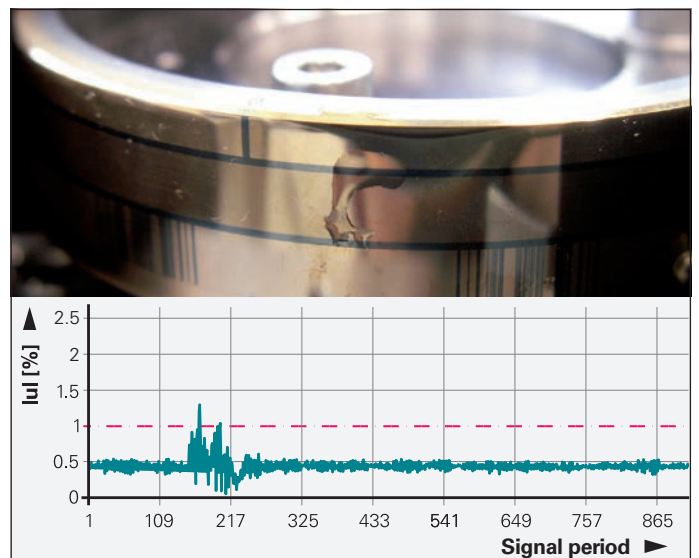

Water droplet contamination

Durable measuring standards

Due to their exposed design, the measuring standards of modular angle encoders with optical scanning are less protected from their environment. For this reason, HEIDENHAIN always uses robust graduations manufactured in special processes.

In the METALLUR process, a reflective gold layer is covered with a thin layer of glass. On this layer are lines of translucent, light-absorbing chrome only several nanometers in thickness. Measuring standards with METALLUR graduations have proven to be particularly robust and insensitive to contamination because the low height of the structure leaves practically no surface for dust, dirt or water particles to accumulate.

In the MAGNODUR process, alternating north and south poles are created on the periphery. Because the graduation lies within the material, contamination on the scale drum has no effect on the signals. This measuring standard becomes damaged only if it comes into direct contact with a magnetic field (e.g., via a tool).

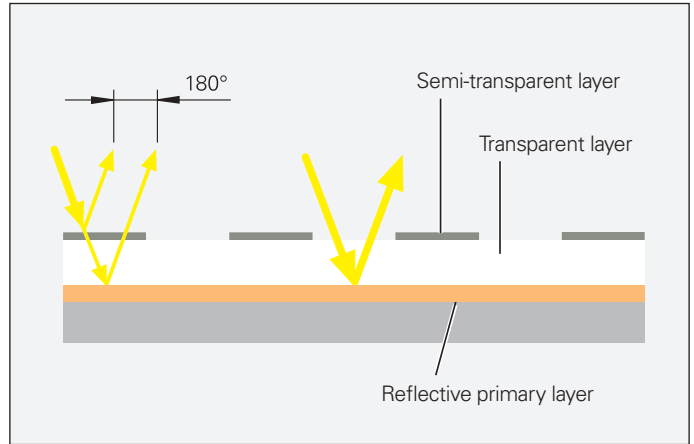

Design of a METALLUR graduation

Application-oriented mounting tolerances

The mounting tolerances of modular angle encoders from HEIDENHAIN have minimal influence on the output signals. In particular, a variation in the scanning gap between the graduation carrier and scanning head causes only negligible change in the signal amplitude, and barely affects the interpolation error within one signal period. This behavior is substantially responsible for the high reliability of angle encoders from HEIDENHAIN.

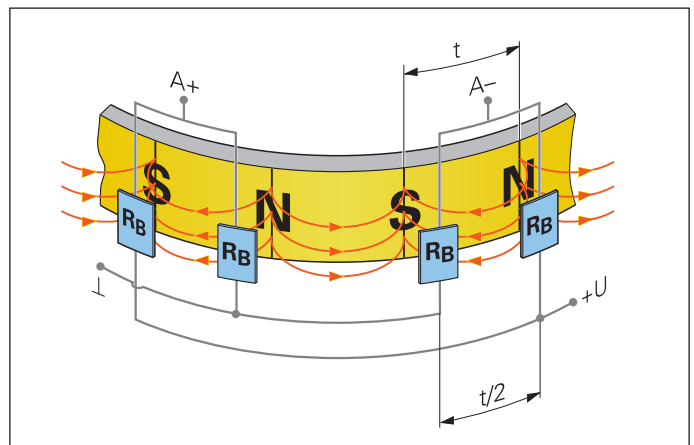

Magnetostrictive scanning principle

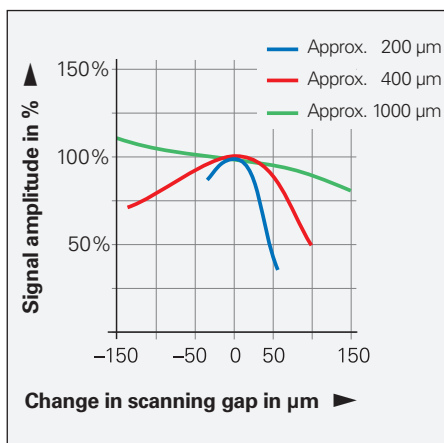

Typical relationship between the signal amplitude and the scanning gap (mounting clearance) for the ECM/ERM 2000

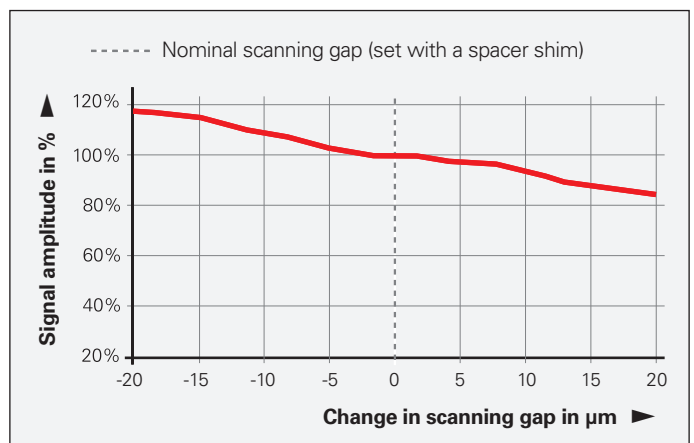

Influence of the scanning gap on the signal amplitude for the ERA 4000

Angle encoders on direct-drive motors

Direct-drive motors are increasingly being used on rotary axes in order, for example, to boost efficiency by increasing the attainable dynamic performance of the axis motion.

Of particular importance for the performance of a direct-drive feed axis is the choice of encoder.

The position and speed feedback of direct-drive motors is achieved with a position encoder. Angle encoder selection must therefore be made on the basis of its usage in the machine:

The higher the speed-stability requirements, particularly at low shaft speeds, the more important are the following factors:

- The signal quality of the encoder, meaning the lowest possible position error within one signal period
- The number of signal periods (with incremental encoders) and the resolution (with absolute encoders)

Limitation in the signal quality of the encoder or the resolution/number of signal periods may cause:

- Increased noise in the motor current and thereby higher power loss and motor heating
- High-frequency noise in the drive train
- Reduced dynamic performance due to the required reduction in gain factors within the position and speed control loops.

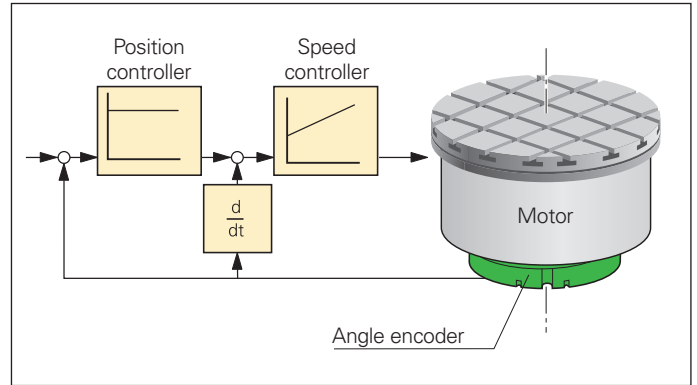

The position feedback from the angle encoder is used as the input for the position controller and speed controller

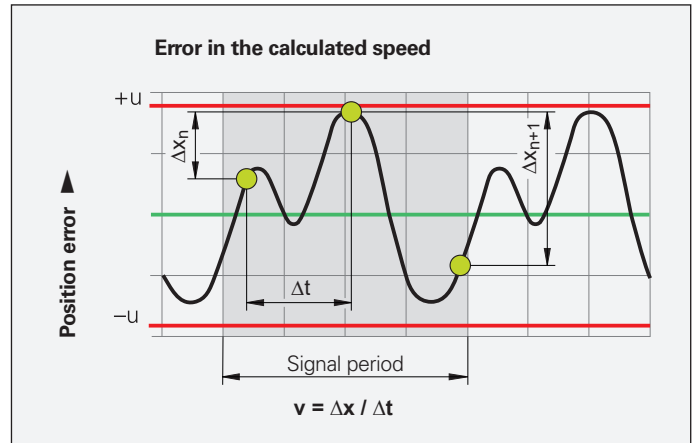

The speed v is calculated from the distance Δx travelled in a time interval Δt ($v = \Delta x / \Delta t$). Position errors within one signal period cause the calculated speed to fluctuate despite constant motion. $(\Delta x_n / \Delta t) \neq (\Delta x_{n+1} / \Delta t)$

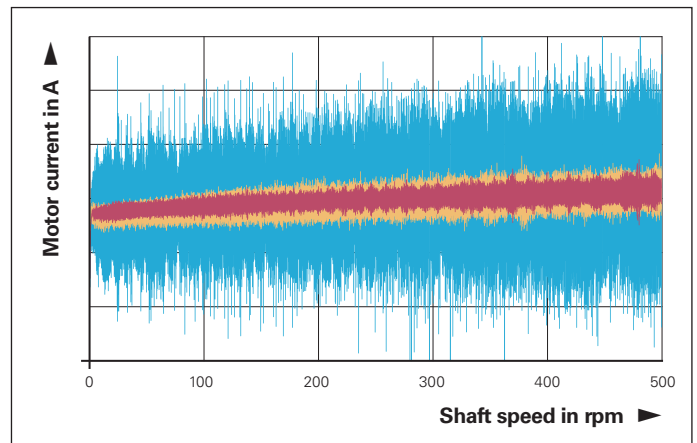

Example of the noise behavior of optical and non-optical angle encoders in rotary tables with a direct-drive motor at a continuously increasing shaft speed

- Optical angle encoder with 32 768 lines
- Optical angle encoder with 16 384 lines
- Non-optical angle encoder with 2 600 lines

Mechanical design types and mounting

Mounting support, functional testing and diagnostics

HEIDENHAIN provides various aids for ensuring easy and optimal initial setup of the modular angle encoder.

Mechanical mounting

High-quality physical mounting within tolerance is essential for ensuring the high reliability of the angle encoder. Please follow the mounting instructions.

Mounting support with the PWM 21

The ERA, ECA and ECM encoders, in conjunction with the PWM 21, offer special, device-specific processes in order to simplify and check for proper mounting.

The ATS software guides users through the necessary individual steps for, say, evaluating the signal quality. It also provides notification if the recommended limit values are not attained.

For incremental encoders, this includes the evaluation of the signal amplitudes, as well as the reference mark position and width. For absolute encoders, evaluation is performed based on valuation numbers and alarms.

Functional testing with the PWT 101 and PWM 21

The PWT 101 and the PWM 21 with the ATS software provide basic functions for all angle encoders. In the case of incremental encoders, for example, the signal quality can be evaluated. Function reserves, warnings and alarms can be output for absolute encoders.

Diagnostics in the control loop

The ECA and ECM absolute encoders transmit valuation numbers to the downstream electronics, thereby enabling diagnostics for the encoders status or determination of the function reserve, including directly within the control loop at the controller. The scaling is the same for all HEIDENHAIN encoders and is stated as a function reserve (from 0% to 100%).

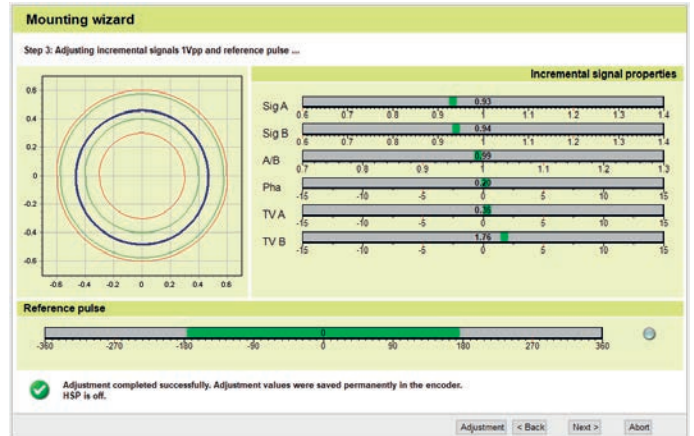

Mounting support for the ERA 4000 with the ATS software and PWM 21

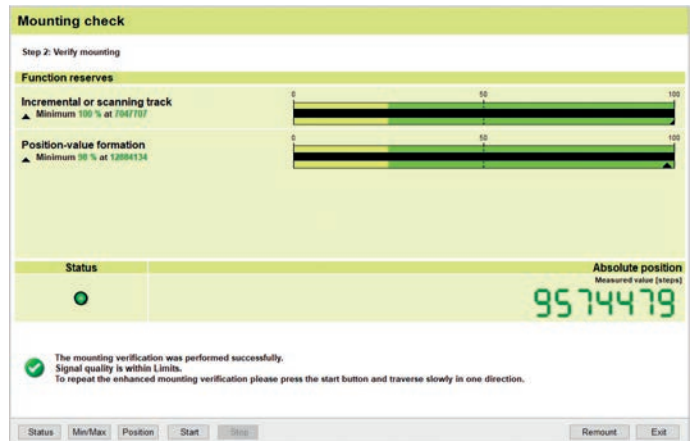

Mounting support, such as for the ECM 2000 with the PWM 21 and ATS software

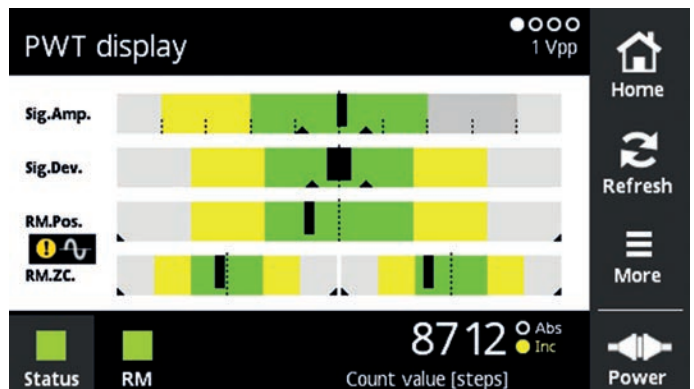

Functionality check, such as for the ERM 2000 with the PWT 101

Signal-quality indicator for the ERA 4000

The ERA 4000 angle encoders feature a built-in signal-quality indicator in the form of a multicolor LED, permitting fast and easy signal-quality checks during operation.

This feature provides a number of benefits:

- Scanning-signal quality visualization through a multicolor LED
- Continuous monitoring of incremental signals over the entire measuring length
- Indication of reference-mark signal behavior
- Quick signal-quality checks in the field without additional aids

The built-in signal-quality indicator permits both a reliable assessment of the incremental signals and inspection of the reference mark signal. The quality of the **incremental signals** is indicated by a range of colors, permitting quite detailed signal-quality differentiation. The tolerance conformity of the **reference mark signal** is shown by means of a pass/fail indicator.

LED indicator for incremental signals

LED color	Quality of the scanning signals
●	Optimal
●	Good
●	Acceptable
●	Unsatisfactory

LED indicator for the reference mark signal
(functional check)

When the reference mark is traversed, the LED briefly lights up in red or blue:

- Out of tolerance
- In tolerance



ERA 4000: Signal-quality indicator in the scanning head

Test film for magnetic graduation for the ECM/ERM 2000

The test film makes magnetic polarity visible. It is ideal for simple inspection in order to detect and prevent damage to the graduation:

- Damage to the magnetic graduation (e.g., demagnetization via a tool)
- Residual magnetism of the tool or screw prior to mounting



Visible marking on the test film after contact with an Allen wrench, as an indicator of tool magnetization

Centering the scale drum

The modular angle encoders are made up of a scanning head and a graduation carrier. The graduation may be implemented in the form of a scale drum or a scale tape. The position of the scanning head and graduation relative to each other is determined solely via the machine guideway. For this reason, the machine must be designed from the very beginning to meet the following prerequisites:

- The **bearing** must be designed such that it meets the accuracy requirements of the axis and the scanning-gap tolerances of the encoder, even during operation (see the *Technical data*).
- The **mounting surface** for the graduation carrier must meet the flatness, roundness, radial runout and diameter requirements of the given encoder.
- To facilitate **adjustment** of the scanning head relative to the graduation, the scanning head should be fastened via a mounting bracket or via appropriate fixed stops.

All modular angle encoders with **scanning drums** are designed such that the specified accuracy can be reached in the actual application. The mounting designs ensure the highest possible reproducibility.

Centering the graduation

Since graduations from HEIDENHAIN have a very high degree of accuracy, the attainable overall accuracy is predominantly affected by mounting errors (mainly eccentricity errors). Various possibilities for centering, depending on the encoder and mounting method, are possible for minimizing the eccentricity errors in practice.

1. Centering collar

The graduation carrier is pressed or shrunk onto the shaft. This very simple method, however, requires a highly exact shaft geometry.

2. Three-point centering

The graduation carrier is centered via three positions marked on the graduation carrier at 120° increments. As a result, any roundness errors of the surface on which the carrier is to be centered do not affect the exact alignment of the axis center point.

3. Centering with two scanning heads

This method is suitable for all modular angle encoders with optical or magnetic scanning and solid graduation carriers. Because HEIDENHAIN graduations exhibit a long-range characteristic error, and because the graduation or the position value itself serves as the reference with this centering method, this is the most accurate centering method.

Scanning heads

Because the modular angle encoders are mounting at the machine, exact mounting of the scanning head is required after mounting of the graduation carrier. In order for the scanning head to be exactly aligned, it must in principle be aligned and adjustable in five axes (see illustration). This adjustment is greatly facilitated by the design of the scanning heads, with the corresponding mounting strategy and wide mounting tolerances.

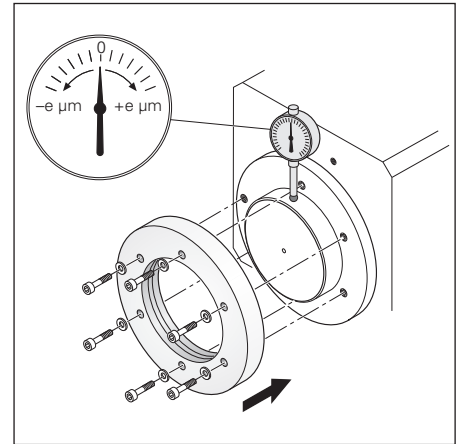

Centering via a centering collar

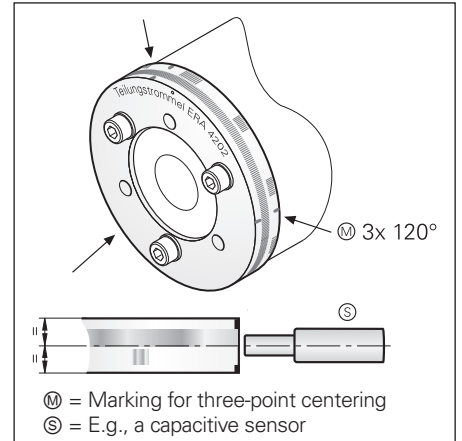

Three-point centering for the ERA

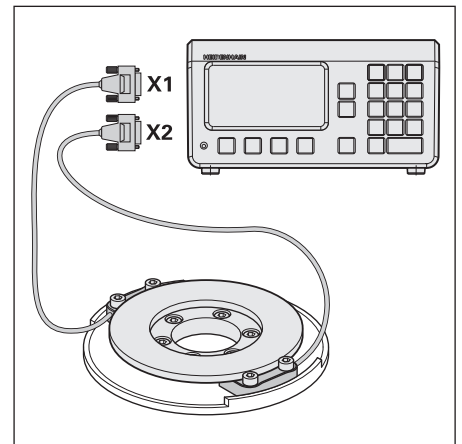

Centering with two scanning heads

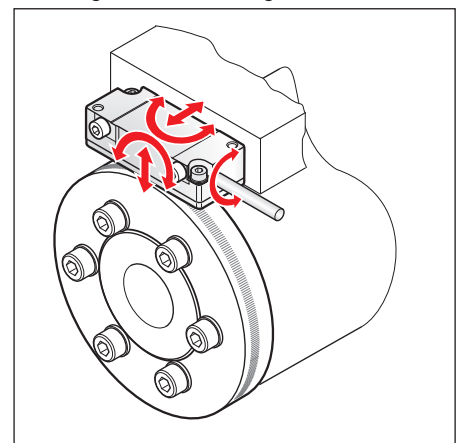

ERA 4000 and ECA 4000 series

The ERA 4000 and ECA 4000 modular angle encoders consist of a scale drum and a scanning head. The scale drums are available in versions with a centering collar and with three-point centering.

The ERA 4x80 versions are available with various grating periods depending on the accuracy requirements. The appropriate scanning heads for the scale drums are shown in the table at the right. Be sure that the diameters or number of signal periods of the scale drum and scanning head match. Protecting the ERA and ECA series encoders from contamination requires special design measures. The ERA 4480 angle encoders can be delivered with an additional sealing-air cover for various scale drum diameters. This requires a special scanning head (with a compressed-air inlet). When ordering the sealing-air cover, be sure that it matches the drum diameter.

Special design features of the ERA and ECA modular angular encoders assure comparatively fast mounting and easy adjustment.

Mounting the ERA 4x00/ECA 4400 scale drums

The scale drum is centered along its inner ring via the centering collar. Two centering methods are possible:

- a) The scale drum is pressed onto the drive shaft or thermally shrunk (see also the Functional Safety section) and fastened with screws. Adjustment of the drum is therefore unnecessary and impossible. The scale drums can and should be heated for assembly. Back-off threads are provided for disassembly.
- b) The scale drums are centered along their inner ring via the centering collar.

Mounting the ERA 4202/ECA 4402 scale drums

The scale drums are centered via three positions at 120° increments on their outer circumference and fastened with screws. The benefits of three-point centering and the solid scale-drum design make it possible to attain very high accuracy when the encoder is mounted, with relatively little mounting effort. The positions for centering are marked on the scale drum. Centering via the inner ring is not possible.

Scale-drum design	Centering methods	Model of scale drum	Appropriate scanning head
With centering collar	<ul style="list-style-type: none"> • Slid or heat-shrunk onto shaft • Centering on the inner ring 	TTR ERA 4200	AK ERA 4280
		TTR ERA 4400	AK ERA 4480
		TTR ERA 4800	AK ERA 4880
		TTR ECA 4400	AK ECA 4410 AK ECA 4490
With three-point centering	<ul style="list-style-type: none"> • Centering along the outer ring 	TTR ERA 4202	AK ERA 4280
		TTR ECA 4402	AK ECA 4410 AK ECA 4490

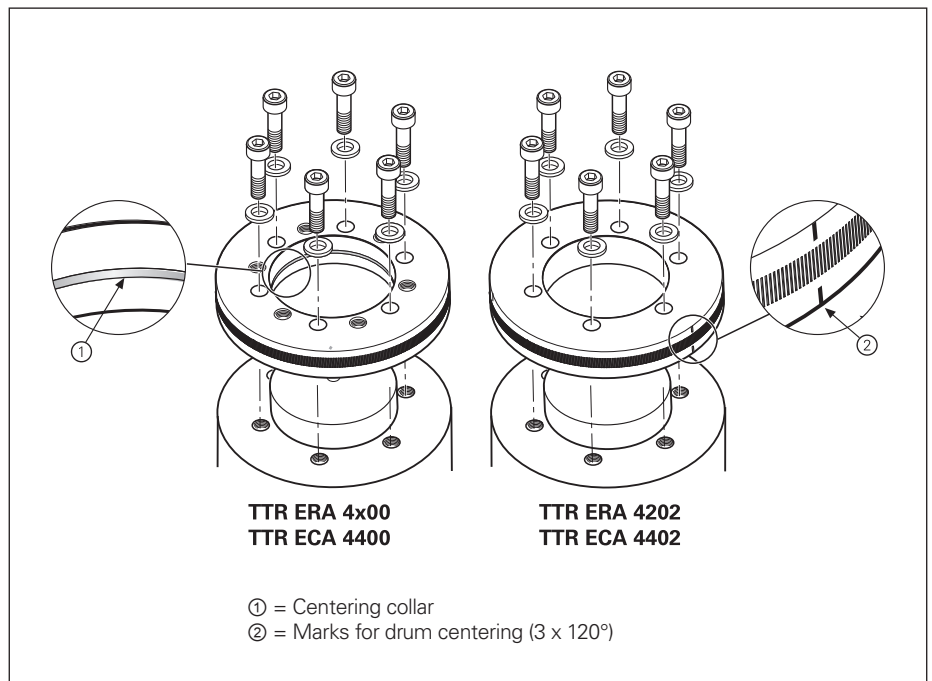

Mounting the scale drums

Along with the encoder-specific centering methods, centering with two scanning heads is possible as well.

Mounting the scanning head

In order for the scanning head to be mounted, a mounting aid is placed between the outer curved surface of the scale drum and the scanning head. The scanning head is pressed against it and then fastened. The shim or mounting aid is then removed.

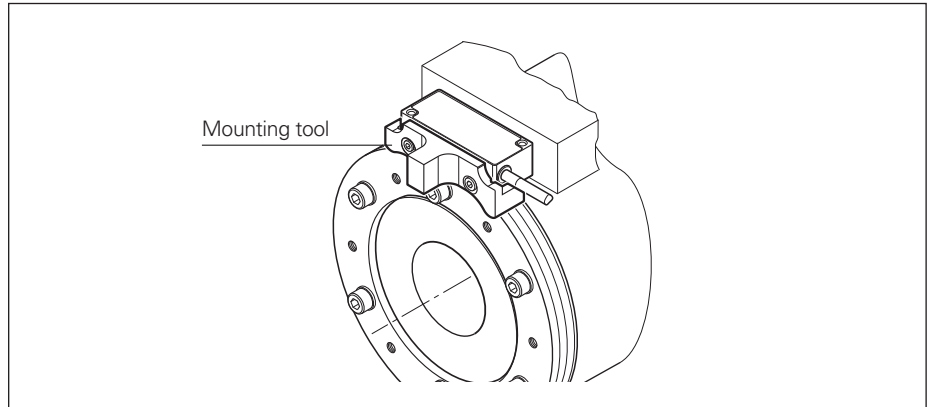

Mounting the scanning head for the ECA 4000/ERA 4000

Mounting the sealing-air cover

Some variants of the ERA 4000 angle encoders are optionally available with sealing-air covers. This cover provides additional protection from contamination when compressed air is applied.

The scale drum and the scanning unit are mounted as described above. The separate spacer shim supplied with the sealing-air cover is laid around the scale drum. It protects the scale drum during mounting of the sealing-air cover and ensures an even scanning gap. The sealing-air cover is then pressed onto the scale drum and fastened. The spacer shim is removed. For information about the compressed-air inlet, see *General mechanical information*.

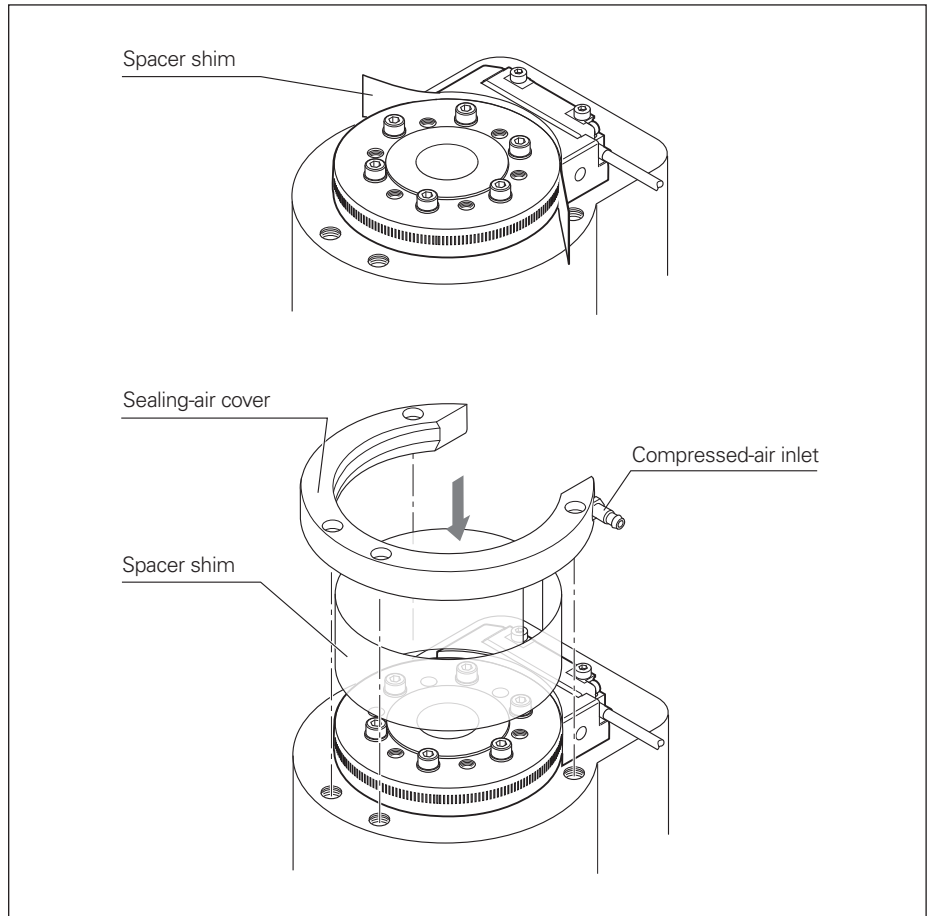

Mounting an ERA 4480 with sealing-air cover

ERM 2000 and ECM 2000 series

The ECM and ERM modular angle encoders consist of a scale drum and a scanning head. This design of the ECM and ERM series enables relatively fast mounting without adjustment work.

The ERM scale drums are available in three versions. The main difference between them is their mounting method. All of the scale drums feature a centering collar on the inner ring.

Mounting the TTR ERM 2200, TTR ERM 2203, TTR ERM 2400 and TTR ECM 2400 scale drums

The scale drum is centered along its inner ring via the centering collar. Two centering methods are possible:

- a) The graduation drum is pressed onto the mating shaft or thermally shrunk (see also the Functional Safety section) and fastened with screws. Adjustment of the drum is therefore unnecessary and impossible. The scale drums can and should be heated for assembly.
- b) The scale drums are centered along their inner ring via the centering collar.

Mounting the TTR ERM 2x00 scale drums

The **TTR ERM 2404** and **TTR ERM 2904** scale drums are clamped to the bearing surface solely via a friction-locked connection. How the scale drum is clamped depends on the mounting situation.

The clamping force must be applied circularly over the plane surface of the drum. The necessary mounting elements depend on the design of the customer's equipment and are therefore the responsibility of the customer. The frictional connection must be strong enough to prevent unintentional rotation or skewing in axial and radial directions, even at high shaft speeds and accelerations.

Designing the mounting elements

For designing the mounting elements, use the following parameters of the scale drum:

Permissible surface pressure:
 $p_{zul} = 100 \text{ N/mm}^2$

Coefficient of thermal expansion:
 $\alpha_{therm} = 10 \cdot 10^{-6} \text{ K}^{-1}$

Average surface roughness of the front mating surfaces:

$R_z \leq 8$ For scale drums with an outside diameter $< 326.9 \text{ mm}$

$R_z \leq 16$ For scale drums with an outside diameter $\geq 326.9 \text{ mm}$

Mounting the TTR ERM 2405 scale drums

The **TTR ERM 2405** scale drums are provided with a keyway. The keyway may be used solely as an anti-rotation element and not for transmitting torque. The special inner shape of the drum for this version also ensures durability even at the highest permissible shaft speeds.

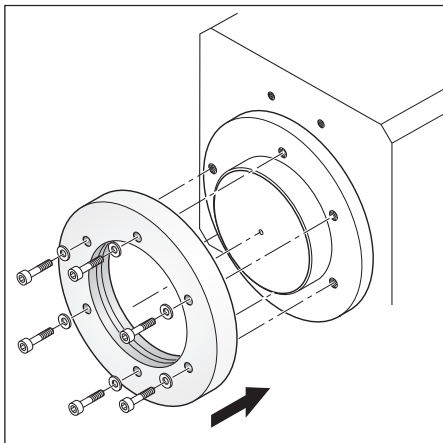

Mounting the scale drum
 TTR ERM 2400
 TTR ERM 2200
 TTR ERM 2203
 TTR ECM 2400

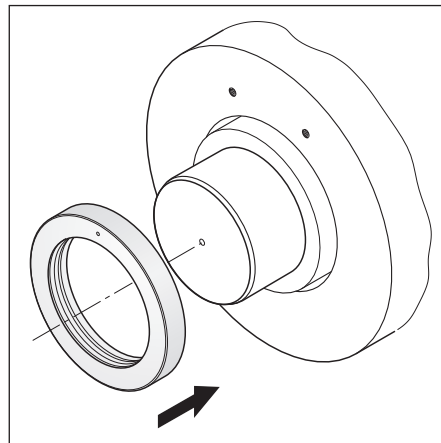

Mounting the scale drum
 TTR ERM 2404
 TTR ERM 2904

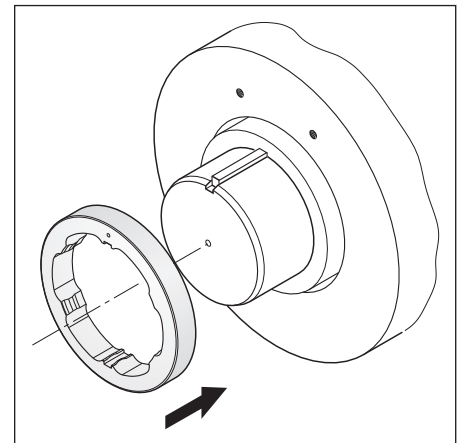

Mounting the scale drum
 TTR ERM 2405

Mounting the scanning head

In order for the scanning head to be mounted, the provided spacer shim is laid on the outer curved surface of the scale drum. The scanning head is pressed against the shim and fastened. The shim is then removed. The scanning heads are available with different cable outlets.

Protection from damage due to magnetic fields

During mounting, ensure that neither the outer curved surface of the scale drum nor the scanning area comes into contact with magnetic fields (e.g., of tools). The use of non-magnetizable tools is recommended. Magnetic field intensities that typically arise during operation (e.g., in the immediate vicinity of motors) do not have any negative effects on the ERM or ECM encoders.

Test film for magnetic graduation

A test film can be used to make the magnetic graduation visible. It enables the user to easily check whether there is any damage to the magnetic graduation, such as demagnetization from a tool. The test film can also be used prior to mounting for checking the tool or screws for residual magnetization in order to prevent damage to the graduation. The test film can be "cleaned" with the aid of a demagnetization device and therefore used repeatedly. The test film and demagnetization device are available as accessories.

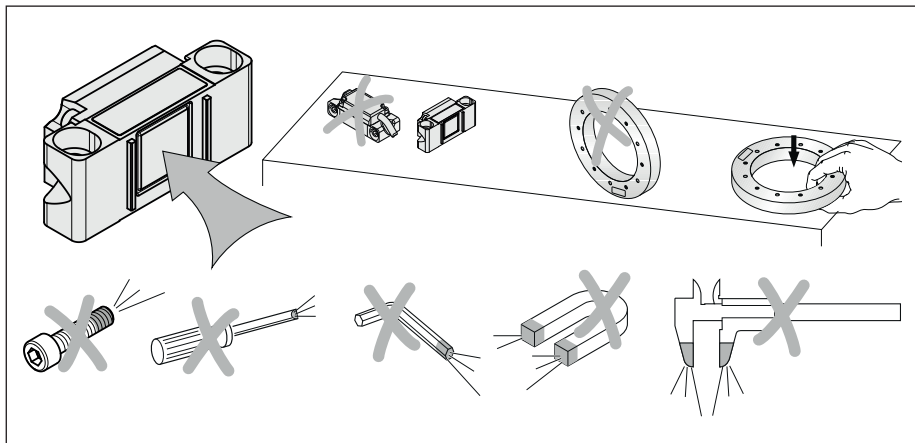

Handling information

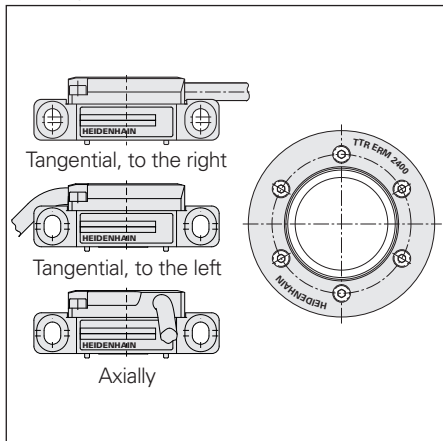

Possible cable outlets

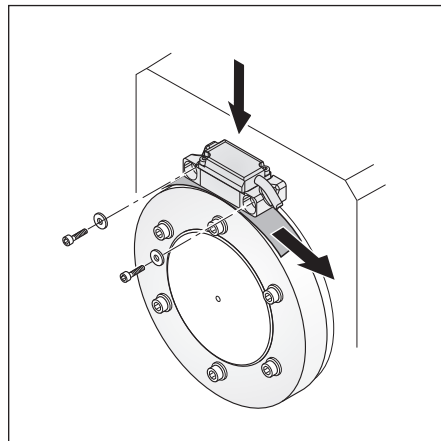

Mounting the scanning head (e.g., AK ERM 2480)

ERA 7000 and ERA 8000 series

The ERA 7000 and ERA 8000 series angle encoders consist of a scanning unit and a single-piece steel scale tape. The steel scale tape is available in lengths of up to 30 m.

The tape is mounted on

- the **inner ring** (ERA 7000 series)
 - the **outer ring** (ERA 8000 series)
- of a machine element.

The ERA 74x0 C and ERA 84x0 C angle encoders are designed for **full-circle applications**. They are therefore ideal for hollow shafts with large inside diameters (approx. 400 mm or larger) and to applications requiring accurate measurement over a large circumference (e.g., large rotary tables, telescopes).

For applications where there is no full circle, or measurement is not required over 360°, **segment solutions** are available.

Mounting the scale tape for full-circle applications

ERA 74x0C: An **internal slot** with a specified diameter is required for receiving the scale tape. The scale tape is inserted starting at the butt joint and is clicked into the slot. The length is cut so that the tape is held in place by its own force.

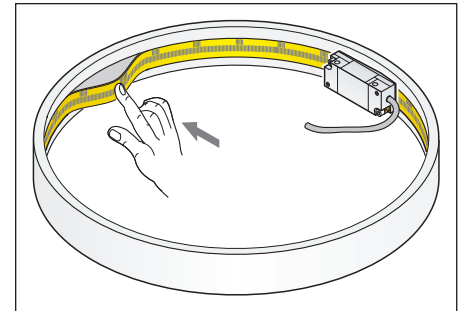

ERA 84x0C: The scale tape is supplied with the halves of the tensioning cleat already mounted to the tape ends. An **external slot** is necessary for mounting, and a recess is required for the tensioning cleat. After the scale tape has been inserted, it is pushed up against the slot edge and tensioned there with the tensioning cleat.

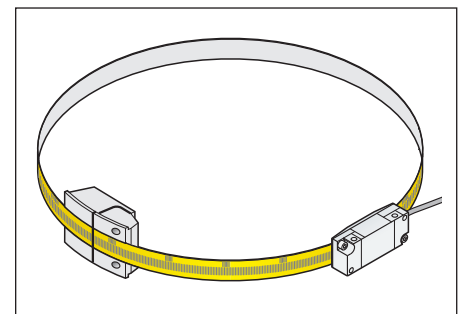

The scale tape ends are manufactured so exactly that only slight angular and signal-shape errors may occur in the area of the butt joint. To ensure that the scale tape does not move within the slot, it is attached near the butt joint with dots of adhesive.

Mounting the scale tape for segment solutions

ERA 74x1C: An internal slot with a specified diameter is required in order to accommodate the scale tape. The two cam disks mounted in this slot are adjusted so that the scale can be pressed into the slot under tension.

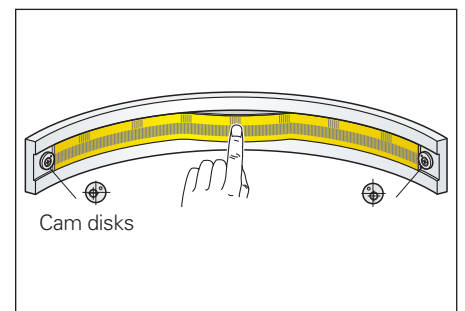

ERA 84x1C: The scale tape is delivered with pre-mounted end pieces. An external slot with recesses for the end pieces is required in order to accommodate the scale tape. The end pieces are fitted with tension springs that ensure optimal preloading of the scale tape and evenly distribute expansion along the entire scale-tape length.

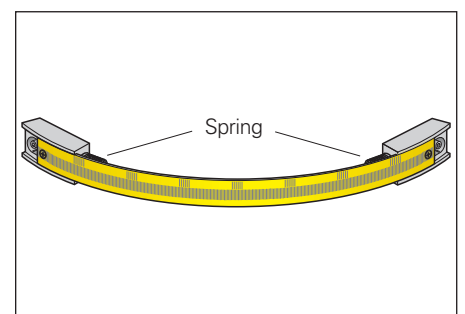

ERA 84x2C: To accommodate the scale tape, an external slot or a single axial edge is recommended. The scale tape is supplied without tensioning elements. It must be preloaded with a spring balance and screw-fastened at the two oblong holes.

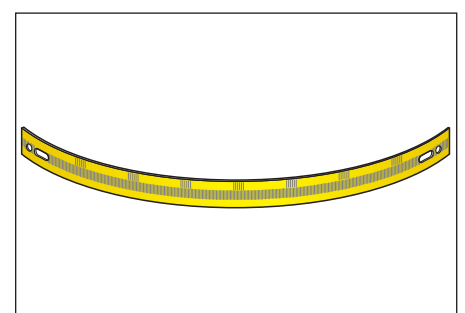

Determining the mating diameter

In order to ensure correct functioning of the distance-coded reference marks, the circumference must be a multiple of 1000 grating periods. The relationship between the mating diameter and the signal period can be seen in the table.

Determining the segment angle

For segment solutions, the angle available as the measuring range must be a multiple of 1000 grating periods. Also, the circumference of the theoretical full circle must be a multiple of 1000 grating periods, since this often simplifies integration with the numerical control.

Mounting the scanning head

For mounting the scanning head, the spacer shim is held against the outer curved surface of the scale drum. The scanning head is pressed against the shim and fastened. The shim is then removed. In addition, the scanning field can be finely adjusted via an eccentric bushing.

Checking the output signals at the butt joint

In order to check whether the scale tapes of the ERA 74x0 C and ERA 84x0 C have been mounted correctly, the output signals should be checked at the butt joint before the adhesive has hardened.

The quality of the output signals can be checked using a PWT phase-angle testing unit from HEIDENHAIN. When the scanning head is moved along the scale tape, the PWT graphically displays the signal quality and the reference mark position.

The PWM 9 phase-angle measuring unit quantitatively displays deviations of the output signals from the ideal signal (see *HEIDENHAIN measuring and testing devices*).

	Mating diameter in mm	Measuring range in degrees for segment solutions
ERA 7000C	$n \cdot 0.01273112 + 0.3$	$n_1 \cdot 4.583204 : (D - 0.3)$
ERA 8000C	$n \cdot 0.0127337 - 0.3$	$n_1 \cdot 4.584121 : (D + 0.3)$

n = Signal period of full circle; n_1 = Signal period of measuring range
 D = Mating diameter [mm]

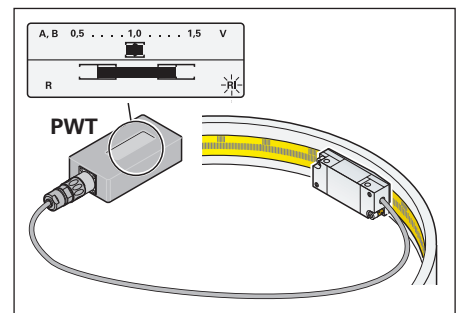
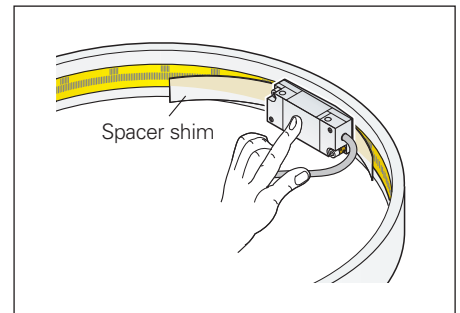
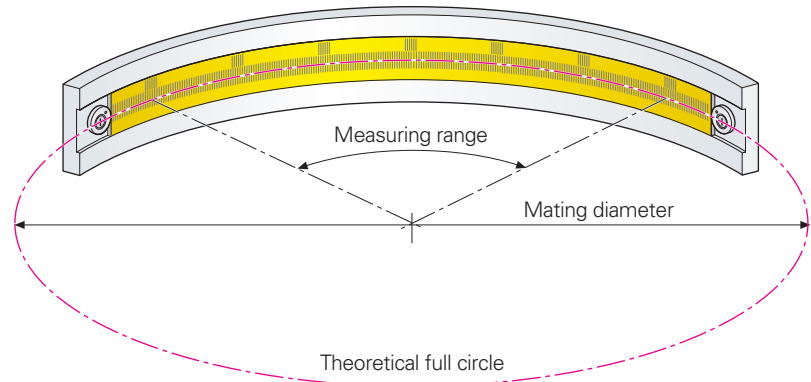

General information

Protection

Modular angle encoders **with optical scanning** must be protected from particulate and liquid contamination in the application. Suitable encapsulation by means of seals and sealing air may be necessary.

The scanning heads themselves partially fulfill the IP40 (ERA) and IP67 (ECA) protection rating in accordance with EN 60529 and IEC 60529.

Optional sealing-air covers are available for several variants of the ERA 4000 angle encoders, permitting a protection rating increase to IP40. Connection to a source of compressed air slightly above atmospheric pressure provides additional protection against condensation. The sealing-air cover is not designed to provide protection from liquid or dust contamination. In many applications, however, the sealing-air cover provides reliable protection. Design-related constraints and operating conditions have a decisive influence.

At a pressure of approx. $1 \cdot 10^5$ Pa (1 bar), the HEIDENHAIN connecting piece with an integrated air inlet ensure a flow rate of approx. 33 liters/rpm. This configuration provides good protection from dust in most cases.

A proven method of avoiding contamination under difficult ambient conditions, both during operation and at standstill, is to adequately cover the area where the encoder is installed (in addition to the sealing-air cover) and flush it with clean compressed air, or to generate slight overpressure.

The compressed air entering the encoder must be purified by a microfilter and comply with the following quality classes as per **ISO 8573-1** (2010 edition):

- Solid contaminants: **Class 1**
Particle size No. of particles per m³
0.1 µm to 0.5 µm ≤ 20 000
0.5 µm to 1.0 µm ≤ 400
1.0 µm to 5.0 µm ≤ 10
- Max. pressure dew point: **Class 4**
(pressure dew point at 3 °C)
- Total oil content: **Class 1**
(max. oil concentration: 0.01 mg/m³)

Accessory:

DA 400 compressed air unit
ID 894602-01

DA 400

HEIDENHAIN offers the DA 400 compressed-air filter system for purifying the compressed air. It is designed specifically for connecting compressed air to encoders.

The DA 400 consists of three filter stages (pre-filter, microfilter and activated carbon filter) and a pressure regulator with a manometer. The sealing air function can be effectively monitored using a manometer and pressure switch (available as an accessory).

The compressed air introduced into the DA 400 must fulfill the requirements of the following purity classes as per **ISO 8573-1** (2010 edition):

- Solid contaminants: **Class 5**
Particle size No. of particles per m³
0.1 µm to 0.5 µm Not specified
0.5 µm to 1.0 µm Not specified
1.0 µm to 5.0 µm ≤ 100 000
- Max. pressure dew point: **Class 6**
(pressure dew point at 10 °C)
- Total oil content: **Class 4**
(max. oil concentration 5 mg/m³)



Further information:

For more information, please request our *DA 400* Product Information.



DA 400

Temperature range

The **operating temperature range**

indicates the ambient temperature limits between which the angle encoders will function properly.

The **storage temperature range** applies to the device within its packaging (ERA/ECA: -20 °C to 70 °C, ERM/ECM: -30 °C to 70 °C).

Protection from contact

After installation of the encoder, all rotating parts must be protected from accidental contact during operation.

Acceleration

Angle encoders are subject to various types of acceleration during operation and installation.

- The indicated maximum values for **vibration resistance** are valid in accordance with EN 60068-2-6.
- The maximum values for the permissible acceleration (sinusoidal shock) for **shock and impact loads** apply at 6 ms (EN 60068-2-27). Impacts or jarring with a hammer, such as in order to align the encoder, are never permitted.

Shaft speeds

The maximum permissible shaft speeds were determined in accordance with the FKM guideline. This guideline serves as a mathematical attestation of component strength with regard to all relevant influences, and it reflects the current state of the art. The requirements for fatigue strength (10^7 million reversals of load) were considered in the calculation of the permissible shaft speeds. Because installation has a significant influence, all requirements and directions in the specifications and mounting instructions must be followed in order for the shaft-speed data to be valid.

RoHS

HEIDENHAIN has tested its products to ensure the use of non-hazardous materials in accordance with the European Directives 2002/95/EC (RoHS) and 2002/96/EC (WEEE). For a Manufacturer's Declaration on RoHS, please consult your sales agency.

Parts subject to wear

Encoders from HEIDENHAIN are designed for a long service life. Preventive maintenance is not required. However, they do contain components that are subject to wear, depending on the application and how they are deployed. This especially applies to cables that are subject to frequent flexing.

System tests

Encoders from HEIDENHAIN are usually integrated as components into complete systems. Such applications require **comprehensive testing of the entire system**, irrespective of the encoder's specifications.

The specifications provided in this brochure apply only to the encoder and not to the entire system. Any operation of the encoder outside of the specified range or outside of its proper and intended use is at the user's own risk. In safety-related systems, the encoder's position value must be tested by the higher-level system after switch-on.

Mounting

The steps and dimensions that must be complied with during mounting are specified solely in the mounting instructions supplied with the device. All mounting-related information in this brochure is therefore provisional and non-binding, and will not become the subject matter of a contract.

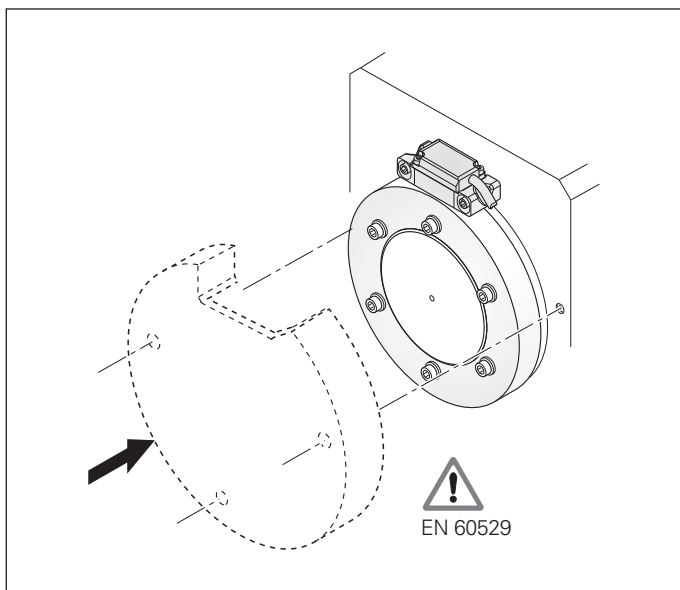

Protection from contact

Functional safety

Safe axes

Driven axes on machine tools usually pose a significant hazard for humans. Particularly when the human interacts with the machine (e.g., during workpiece setup), it must be ensured that the machine tool does not make any uncontrolled movements. Here, the position information of the axes is needed in order to implement a safety function. As an evaluating safety module, the controller detects faulty position information and reacts to it accordingly.

Various safety strategies can be pursued, depending on the topology of the axis and the evaluation capabilities of the controller. In a single-encoder system, for example, only one encoder per axis is evaluated for the safety function. However, on axes with two encoders, such as a rotational axis with a rotary encoder and an angle encoder, the two redundant position values can be compared with each other in the controller.

Safety-related fault detection can be ensured only if the two components, the controller and the encoder, are properly matched to each other. In this case, it must be noted that the safety designs may vary by controller manufacturer. This also means that the requirements placed on the connected encoders may differ.

Type-examined encoders

Modular angle encoders from HEIDENHAIN thrive in a wide variety of safety designs with a variety of controllers. Particularly noteworthy are the type-examined ECA 4410 and ECM 2410 encoders with the EnDat interface. These encoders can be operated as single-encoder systems in conjunction with a suitable controller in applications with the controller category SIL 2 (as per EN 61508) or performance level "d" (as per EN ISO 13849). Unlike incremental encoders, the ECA 4410/ECM 2410 absolute angle encoders always provide a safe absolute position value, including immediately after switch-on or

a power failure. The reliable transmission of the position is based on two independently generated absolute position values and on error bits provided to the safe controller. The purely serial data transmission also offers other advantages, such as greater reliability, improved accuracy, diagnostic capabilities and reduced costs through simpler connection technology.

Standard encoders

In addition to those encoders explicitly certified for safety applications, standard angle encoders can also be used in safe axes (e.g., with 1 V_{PP} signals or Fanuc interface). In this case, the characteristics of the encoders must be matched to the requirements of the respective controller. HEIDENHAIN can provide additional data about the individual encoders (failure rate, fault model as per EN 61800-5-2).

Service life

Unless otherwise specified, HEIDENHAIN encoders are designed for a service life of 20 years (in accordance with ISO 13849).

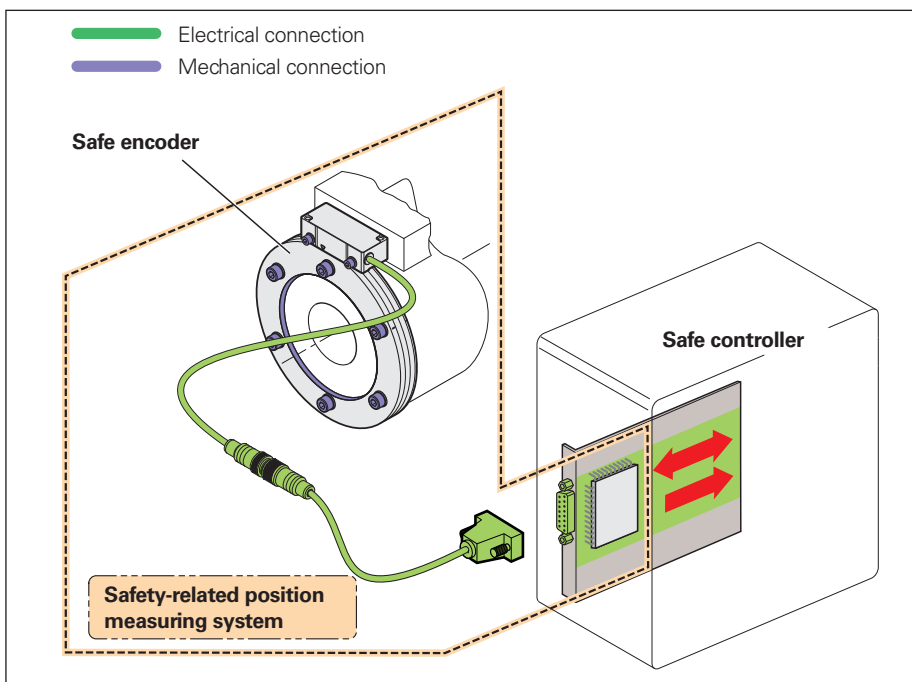

Encoder with mechanical connection and electrical interface



Further information:

The safety-related characteristic values are listed in the encoder specifications. The Technical Information document *Safety-Related Position Encoders* provides explanations about the characteristic values.

Upon request, HEIDENHAIN can also provide additional data about the individual products (failure rate, fault model as per EN 61800-5-2) for the use of standard encoders in safety-related applications.

Fault exclusion for the loosening of the mechanical connection

Irrespective of the interface, many safety designs require the safe mechanical connection of the encoder. The standard for electric motors, EN 61800-5-2, requires that the loosening of the mechanical connection between the encoder and the motor be considered as a fault. Because the controller may not be able to detect these errors, fault exclusion is required in many cases.

This mechanical fault exclusion has been certified for a wide range of encoder applications. This means that the fault exclusion is ensured for the operating conditions listed below.

The requirements for fault exclusion can result in additional constraints in the permissible limit values in the specifications. In addition, fault exclusions for the loosening of the mechanical coupling usually require additional measures during installation of the encoder or in the event of servicing (e.g., anti-rotation lock for screws). These factors must be considered for the selection of a suitable encoder and mounting method.

Fault exclusion for scanning heads and scale drums

There are various mounting possibilities for the scanning heads that offer fault exclusion for the loosening of the mechanical connection. The fault exclusions apply to all scanning heads, regardless of the interface. Among the scale drums, the TTR ECA 4400, TTR ERA 4x00, TTR ECM 2400, TTR ERM 2x00 and TTR ERM 2203 scale drum types provide fault exclusion for the loosening of the mechanical connection. If no mechanical fault exclusion is required for the safety design, then the scale drum can be mounted without a press-fit.

Mechanical connection		Fastening	Safe position for the mechanical coupling ³⁾	Constrained characteristic values ⁴⁾
ERA ECA	Scale drum	Press-fit as per dimension drawing Screw connection: ^{1) 2)} ISO 4762-M5x20-8.8 screws ISO 4762-M6x25-8.8 screws	Drum outside diameter 104.63 mm to 127.64 mm: ±0.025°	See <i>Specifications</i> : <ul style="list-style-type: none"> • Vibration (possibly) • Shock • Maximum angular acceleration • Operating temperature See <i>Dimensions</i> : <ul style="list-style-type: none"> • Mounting tolerances • Mating dimensions See <i>Mounting information</i> : <ul style="list-style-type: none"> • Material • Mounting conditions
	Scanning head	Mounting type I: Screw connection: ²⁾ ISO 4762-M3x25-8.8 screws	Drum outside diameter 148.2 mm or larger: ±0.0°	
		Mounting type II: Screw connection: ²⁾ M3x20 ISO 4762 8.8 screws		
ERM ECM	Scale drum	Press-fit as per dimension drawing (W2) Screw connection: ²⁾ M5 ISO 4762 8.8 screws	±0.025°	
	Scanning head	Screw connection: ²⁾ M4 ISO 4762 8.8 screws		

¹⁾ A material bonding anti-rotation lock must be used for the screw connections of the scale drums (mounting/servicing)

²⁾ Friction Class B as per VDI 2230

³⁾ Fault exclusions exist only for the explicitly stated mounting conditions

⁴⁾ Unlike the ECA/ERA 4xxx and ECM/ERM 2xxx, without mechanical fault exclusion

Mounting the scale drum

A press-fit of the scale drum on the shaft is required for fault exclusion. Preferably, the scale drum should be thermally shrunk onto the mating shaft and fastened with screws. For this purpose, the scale drum must be slowly heated prior to mounting, such as with a heating plate (caution: do not use induction heating sources). The diagram shows the recommended minimum temperatures for the different drum diameters. The maximum temperature must not exceed 140 °C.

During shrink-fitting, make sure that the hole patterns of the scale drum and mating shaft are properly aligned. Appropriate centering aids (setscrews) can facilitate mounting. All of the mounting screws must be retightened at the correct torque after the scale drum has cooled. The mounting screws used for attaching the scanning head and scale drum may be used only to secure the scanning head and the scale drum. These screws may not be used to additionally fasten other components.

Removing the scale drum

The scale drum is removed using the relevant back-off threads in the drum. To do this, insert greased screws, and tighten them in a row until the scale drum comes off the shaft. Prior to renewed mounting of the scale drum, the back-off threads must be recut.

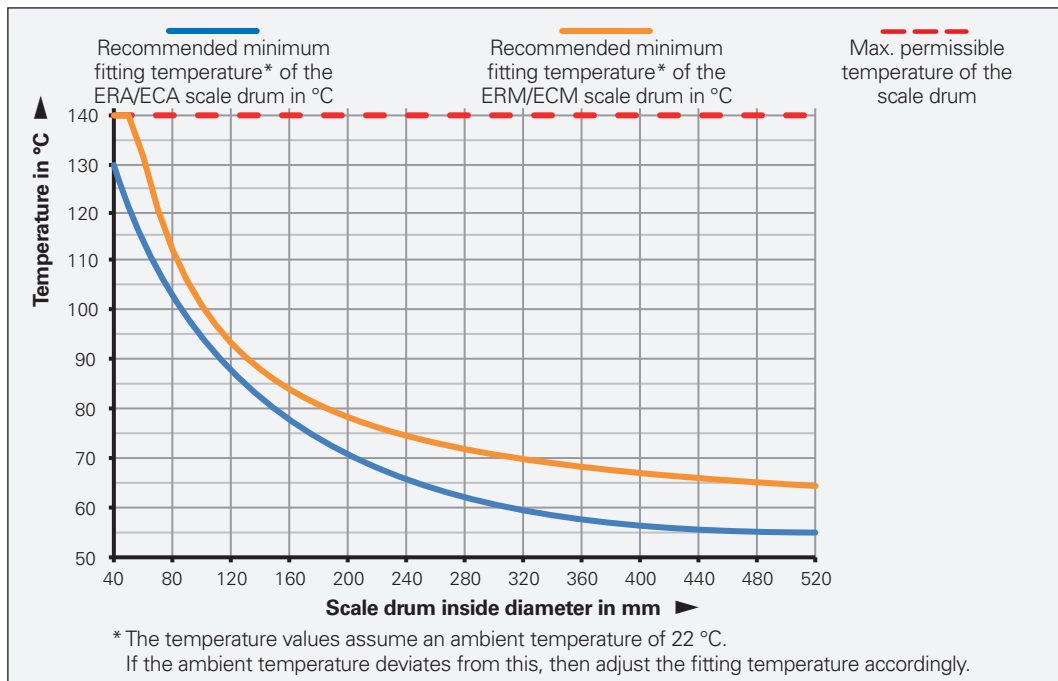

Material

For the mating shaft and the mating stator, use materials in accordance with the table.

Mounting temperature

All information on screw connections is based on a mounting temperature of 15 °C to 35 °C.

Mounting the scanning head

Ensure that the diameter specifications for all encoder components match (scale drum, scanning head, mounting aid for ERA/ECA). The relevant information is indicated on the ID labels. A mounting wizard in the ATS software helps ensure that the scanning head and the scale drum are properly aligned.

Accessories:

- Mounting aid for the ERA/ECA (as per drum diameter)
- Mounting wizard in ATS software

ERM/ECM

	Mating shaft	Mating stator
Material	Steel	Steel/cast iron
Tensile strength R_m	$\geq 600 \text{ N/mm}^2$	$\geq 250 \text{ N/mm}^2$
Shear strength τ_m	$\geq 390 \text{ N/mm}^2$	$\geq 290 \text{ N/mm}^2$
Elastic modulus E	$\geq 200\,000 \text{ N/mm}^2$ to $215\,000 \text{ N/mm}^2$	$110\,000 \text{ N/mm}^2$ to $215\,000 \text{ N/mm}^2$
Coefficient of thermal expansion α_{therm}	$(10 \text{ to } 13) \cdot 10^{-6} \text{ K}^{-1} 1)$	

1) Others upon request

ERA/ECA

	Mating shaft / Mating stator
Material	Steel
Tensile strength R_m	$\geq 600 \text{ N/mm}^2$
Shear strength τ_m	$\geq 390 \text{ N/mm}^2$
Elastic modulus E	$\geq 200\,000 \text{ N/mm}^2$ to $215\,000 \text{ N/mm}^2$
Coefficient of thermal expansion α_{therm}	$(10 \text{ to } 13) \cdot 10^{-6} \text{ K}^{-1} 1)$

1) Others upon request



Further information:

Comply with the requirements described in the following documents to ensure correct and intended operation:

- Mounting Instructions and possibly Operating Instructions of the given product
 - AK ECA 4410 Functional Safety 1177157
 - TTR ECA 4400 1177156
 - TTR ECA 4402 1125430
 - Mounting assistant for the ECA 44xx 1126455

- AK ECM 2410/2490 M/2490 F 1308377
- TTR ECM 2400 1308375
- Mounting assistant for the ECM 24x0 1356342

- Technical Information: *Safety-Related Position Measuring Systems* 596632

For implementation in a controller:

- Specification for safe controller 533095

ECA 4400 series

Absolute angle encoder with high accuracy

- Steel scale drums with three-point centering or centering collar
- Consists of a scanning head and scale drum
- Also for safety-related applications
- Mechanical fault exclusion for scanning heads and scale drum



ECA 4000

With mechanical fault exclusion

Scanning head

Interface

Ordering designation

Clock frequency

Calculation time t_{cal}

Functional safety

for applications with up to

PFH

Electrical connection

Cable length¹⁾

Supply voltage

Power consumption (max.)

Current consumption (typical)

Vibration: 55 to 2000 Hz

Shock: 6 ms

Operating temperature

Protection EN 60529³⁾

Mass

Scanning head
Cable
M12 coupling
D-sub connector

AK ECA 4410 	AK ECA 4410	AK ECA 4490F	AK ECA 4490M	AK ECA 4490P	AK ECA 4490Y
EnDat 2.2		Fanuc Serial Interface; αi Interface	Mitsubishi high speed interface	Panasonic Serial Interface	Yaskawa Serial Interface
EnDat22		Fanuc05	Mit03-4	Pana02	YEC07
≤ 16 MHz		-			
≤ 5 μs		-			
<ul style="list-style-type: none"> • SIL 2 as per EN 61508 (other basis for testing: IEC 61800-5-3) • Category 3, PL "d" as per EN ISO 13849-1:2015 	-				
≤ 20 · 10 ⁻⁹ (up to 6000 m above sea level)	-				
Cable (1 m or 3 m) with 8-pin M12 coupling (male) or 15-pin D-sub connector					
≤ 100 m		≤ 50 m	≤ 30 m	≤ 50 m	
DC 3.6V to 14 V					
At 3.6 V: 700 mW At 14 V: 800 mW		At 3.6 V: 850 mW At 14 V: 950 mW			
At 5 V: 90 mA (without load)		At 5 V: 100 mA (without load)			
≤ 200 m/s ² (EN 60068-2-6) ≤ 200 m/s ² (EN 60068-2-27)	≤ 500 m/s ² (EN 60068-2-6) ≤ 1000 m/s ² (EN 60068-2-27)				
-10 °C to 70 °C ²⁾	-10 °C to 70 °C				
IP67					
18 g (without cable) 20 g/m 15 g 32 g					

¹⁾ With HEIDENHAIN cable; clock frequency ≤ 8 MHz

²⁾ With a drum outside diameter of 104.63 mm: 10 °C to 70 °C

³⁾ In the application, the device must be protected from contamination by solids and liquids. If necessary, use a suitable enclosure with sealing air and a seal

Optionally with mechanical fault exclusion

Scale drum	TTR ECA 4400								
Measuring standard Coefficient of expansion	Steel drum with centering collar $\alpha_{\text{therm}} \approx 10.4 \cdot 10^{-6} \text{ K}^{-1}$								
Drum inside diameter*	70 mm	80 mm	120 mm	120 mm	150 mm	180 mm	270 mm	425 mm	512 mm
Drum outside diameter*	104.63 mm	127.64 mm	148.2 mm	178.55 mm	208.89 mm	254.93 mm	331.31 mm	484.07 mm	560.46 mm
Safe position ^{1) 2)}	±0.88°		±0.44°			±0.22°		±0.11°	
Safety-related measuring step SM	0.352° (10 bits)		0.176° (11 bits)			0.088° (12 bits)		0.044° (13 bits)	
Mech. permissible speed									
With mechanical fault exclusion	8500 rpm	6250 rpm	5250 rpm	4500 rpm	4250 rpm	3250 rpm	2500 rpm	1800 rpm	1500 rpm
Without mechanical fault exclusion	15000 rpm	12250 rpm	10500 rpm	8750 rpm	7500 rpm	6250 rpm	4750 rpm	3250 rpm	2750 rpm
Max. angular acceleration	14 000 rad/s ²	6600 rad/s ²	7900 rad/s ²	2700 rad/s ²	1800 rad/s ²	1000 rad/s ²	1300 rad/s ²	900 rad/s ²	1200 rad/s ²
Elec. permissible speed	≤ 7000 rpm	≤ 5750 rpm	≤ 4400 rpm	≤ 3000 rpm	≤ 2550 rpm	≤ 2100 rpm	≤ 900 rpm	≤ 600 rpm	≤ 550 rpm
Moment of inertia	$0.81 \cdot 10^{-3} \text{ kgm}^2$	$1.9 \cdot 10^{-3} \text{ kgm}^2$	$2.3 \cdot 10^{-3} \text{ kgm}^2$	$7.1 \cdot 10^{-3} \text{ kgm}^2$	$12 \cdot 10^{-3} \text{ kgm}^2$	$28 \cdot 10^{-3} \text{ kgm}^2$	$59 \cdot 10^{-3} \text{ kgm}^2$	$195 \cdot 10^{-3} \text{ kgm}^2$	$258 \cdot 10^{-3} \text{ kgm}^2$
Permissible axial movement	≤ ±0.4 mm (scale drum relative to the scanning head)								
Positions per revolution	134217728 (27 bits)					268435456 (28 bits)		536870912 (29 bits)	
Measuring step	0.0097"					0.0048"		0.0024"	
Signal periods	8195	10 010	11 616	14 003	16 379	19 998	25 993	37 994	44 000
Accuracy of graduation	±3.7"	±3.0"	±2.8"	±2.5"	±2.5"	±2.5"	±2.5"	±2.0"	±2.0"
Interpolation error per signal period	±0.20"	±0.16"	±0.14"	±0.12"	±0.10"	±0.08"	±0.06"	±0.04"	±0.04"
Protection EN 60529 ³⁾	Complete encoder after mounting: IP00								
Mass	≈ 0.40 kg	≈ 0.68 kg	≈ 0.51 kg	≈ 1.2 kg	≈ 1.5 kg	≈ 2.3 kg	≈ 2.6 kg	≈ 3.8 kg	≈ 3.6 kg

* Please select when ordering

¹⁾ Further deviations may arise in the downstream electronics after position value comparison (contact mfr. of the downstream electronics)

²⁾ *Mechanical coupling*: Fault exclusion for the loosening of the scanning head and scale drum, see *Functional safety*

³⁾ In the application, the device must be protected from contamination by solids and liquids.
If necessary, use a suitable enclosure with a seal and sealing air

Without mechanical fault exclusion

Scale drum	TTR ECA 4402								
Measuring standard Coefficient of expansion	Steel drum with three-point centering $\alpha_{\text{therm}} \approx 10.4 \cdot 10^{-6} \text{ K}^{-1}$								
Drum inside diameter*	70 mm	80 mm	120 mm/ 150 mm	130 mm	150 mm/ 185 mm	180 mm/ 210 mm	270 mm	425 mm	512 mm
Drum outside diameter*	104.63 mm	127.64 mm	178.55 mm	148.20 mm	208.89 mm	254.93 mm	331.31 mm	484.07 mm	560.46 mm
Mech. permissible speed	15000 rpm	12250 rpm	8750 rpm	10500 rpm	7500 rpm	6250 rpm	4750 rpm	3250 rpm	2750 rpm
Elec. permissible speed	≤ 7000 rpm	≤ 5750 rpm	≤ 3000 rpm	≤ 4400 rpm	≤ 2550 rpm	≤ 2100 rpm	≤ 900 rpm	≤ 600 rpm	≤ 550 rpm
Moment of inertia	$0.83 \cdot 10^{-3} \text{ kgm}^2$	$2.0 \cdot 10^{-3} \text{ kgm}^2$	$7.1 \cdot 10^{-3} \text{ kgm}^2 /$ $4.5 \cdot 10^{-3} \text{ kgm}^2$	$1.7 \cdot 10^{-3} \text{ kgm}^2$	$12 \cdot 10^{-3} \text{ kgm}^2 /$ $6.5 \cdot 10^{-3} \text{ kgm}^2$	$28 \cdot 10^{-3} \text{ kgm}^2 /$ $20 \cdot 10^{-3} \text{ kgm}^2$	$59 \cdot 10^{-3} \text{ kgm}^2$	$199 \cdot 10^{-3} \text{ kgm}^2$	$263 \cdot 10^{-3} \text{ kgm}^2$
Permissible axial movement	≤ ±0.4 mm (scale drum relative to the scanning head)								
Positions per revolution	134217728 (27 bits)					268435456 (28 bits)		536870912 (29 bits)	
Measuring step	0.0097"					0.0048"		0.0024"	
Signal periods	8195	10010	14003	11616	16379	19998	25993	37994	44000
Accuracy of graduation	±3"	±2.5"	±2"	±2.3"	±1.9"	±1.8"	±1.7"	±1.5"	±1.5"
Interpolation error per signal period	±0.20"	±0.16"	±0.12"	±0.14"	±0.10"	±0.08"	±0.06"	±0.04"	±0.04"
Protection EN 60529¹⁾	Complete encoder after mounting: IP00								
Mass	≈ 0.42 kg	≈ 0.69 kg	≈ 1.2 kg/ ≈ 0.66 kg	≈ 0.35 kg	≈ 1.5 kg/ ≈ 0.66 kg	≈ 2.3 kg/ ≈ 1.5 kg	≈ 2.6 kg	≈ 3.8 kg	≈ 3.7 kg

* Please select when ordering

¹⁾ In the application, the device must be protected from contamination by solids and liquids.

If necessary, use a suitable enclosure with a seal and sealing air

ECA 4410, ECA 4490 (scale drum with centering collar)

Dimensions

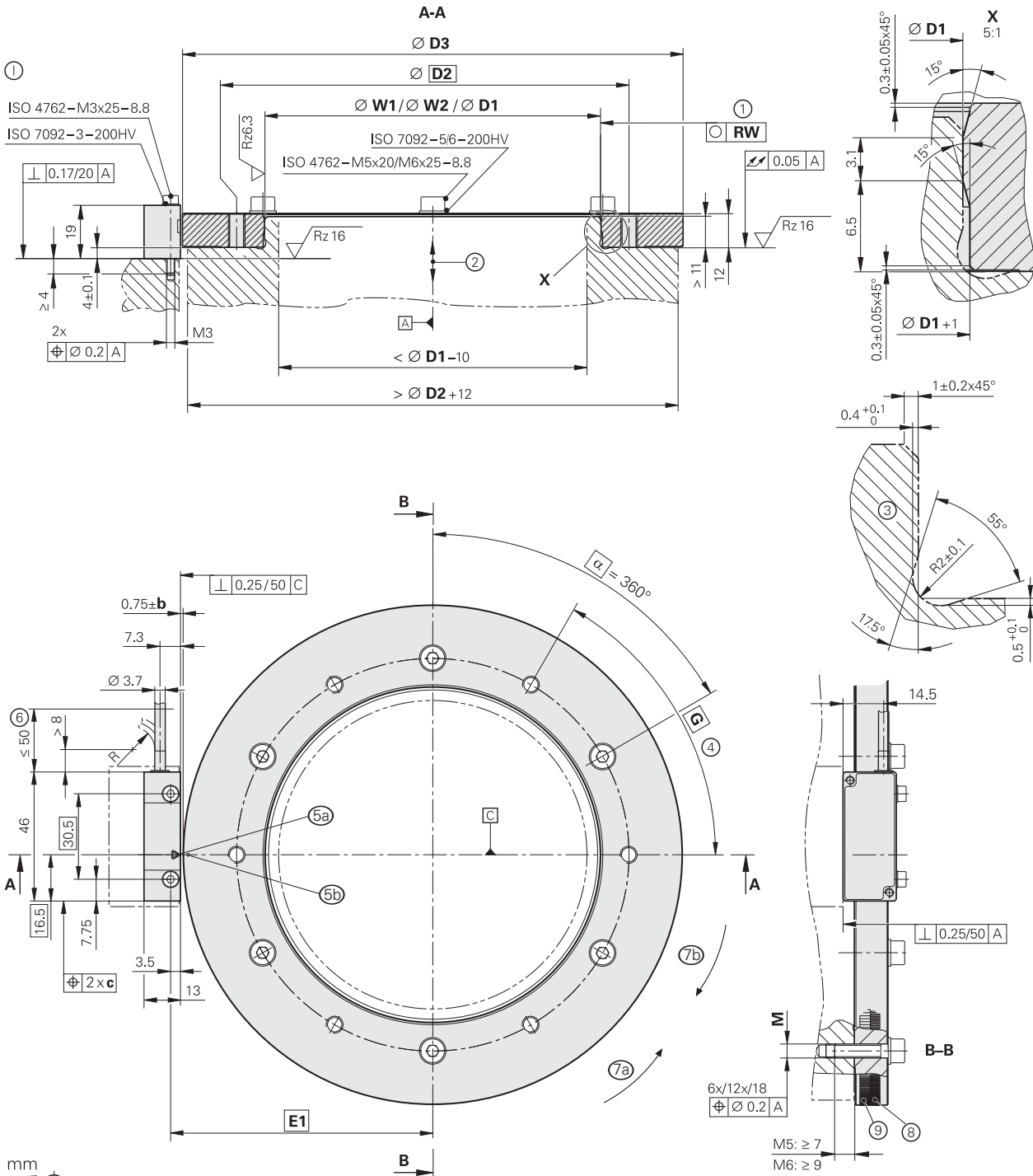

mm
 Tolerancing ISO 8015
 ISO 2768:1989-mH
 ≤ 6 mm: ±0.2 mm

- W1** = Without mechanical fault exclusion
- W2** = With mechanical fault exclusion
- ①, ② = Mounting possibilities
- ▣ = Bearing of mating shaft
- W = Mating diameter (shaft)
- 1 = Roundness of mating diameter (shaft)
- 2 = Permissible axial motion of measured shaft: ≤ ±0.4 mm
- 3 = Proposed design for undercut
- 4 = Back-off thread, not permitted for drum fastening

- 5 = Optical centerline
- 6 = Cable support
- 7a = Positive direction of rotation for scanning heads **with** functional safety
- 7b = Positive direction of rotation for scanning heads **without** functional safety
- 8 = Incremental track
- 9 = Absolute track
- 10 = Space for mounting aid
- 11 = Mounting aid

	b [mm]	c [mm]
∅ 70	±0.05	0.3
∅ 80	±0.07	0.3
∅ 120	±0.07	0.3
∅ 120	±0.10	0.3
∅ 150	±0.12	0.5
∅ 180	±0.12	0.5
∅ 270	±0.15	1.0
∅ 425	±0.15	1.0
∅ 512	±0.15	1.0

II

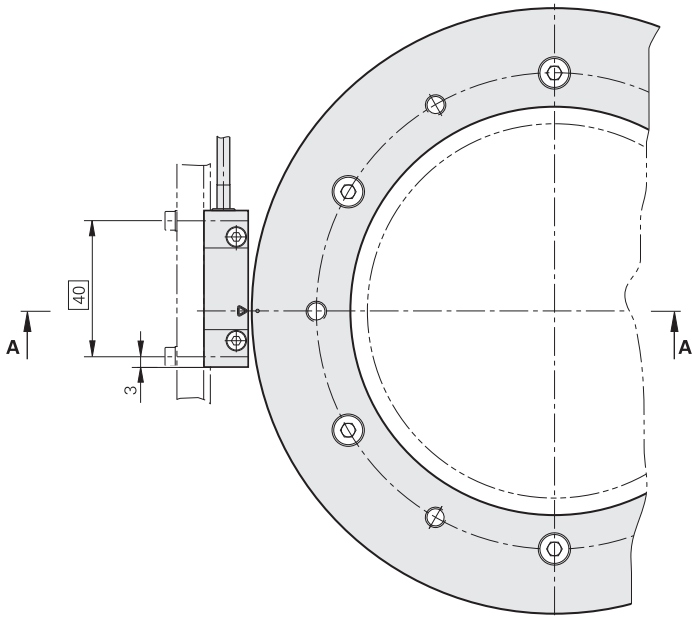
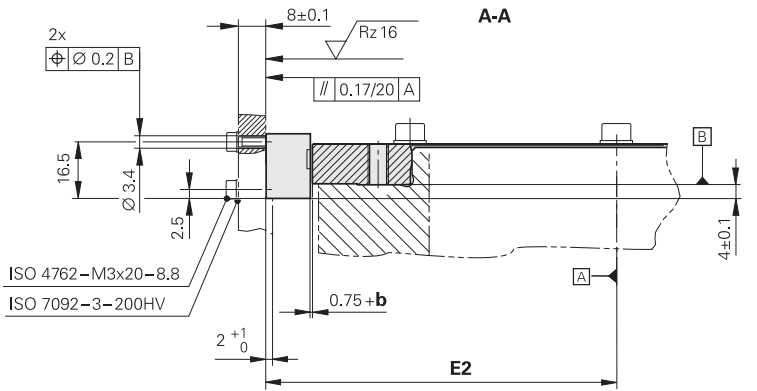

Accessory: Mounting aid

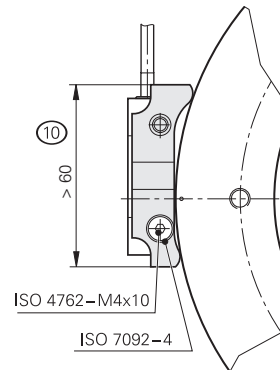
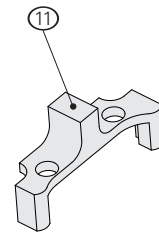
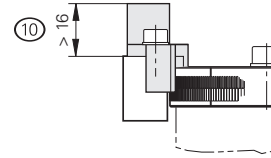

D1	W1	W2	RW	D2	D3	E1	E2	α	M	G
Ø 70 -0.001/-0.005	Ø 70 +0.005	Ø 70 +0.007/+0.002	0.001	Ø 85	Ø 104.63	56.57	66.07	6x60°	6x M5	6x M6
Ø 80 -0.001/-0.005	Ø 80 +0.006	Ø 80 +0.009/+0.003	0.0015	Ø 95	Ø 127.64	68.07	77.57	6x60°	6x M5	6x M6
Ø 120 -0.001/-0.008	Ø 120 +0.008	Ø 120 +0.040/+0.022	0.002	Ø 134	Ø 148.20	78.35	87.85	6x60°	6x M5	6x M6
Ø 120 -0.001/-0.008	Ø 120 +0.008	Ø 120 +0.040/+0.022	0.002	Ø 140	Ø 178.55	93.52	103.02	6x60°	6x M5	6x M6
Ø 150 -0.001/-0.008	Ø 150 +0.008	Ø 150 +0.046/+0.028	0.002	Ø 165	Ø 208.89	108.69	118.19	6x60°	6x M5	6x M6
Ø 180 -0.001/-0.008	Ø 180 +0.010	Ø 180 +0.050/+0.030	0.003	Ø 200	Ø 254.93	131.71	141.21	6x60°	6x M5	6x M6
Ø 270 0/-0.01	Ø 270 +0.012	Ø 270 +0.067/+0.044	0.003	Ø 290	Ø 331.31	169.90	179.40	12x30°	12x M5	12x M6
Ø 425 0/-0.01	Ø 425 +0.015	Ø 425 +0.094/+0.067	0.006	Ø 445	Ø 484.07	246.29	255.79	12x30°	12x M6	12x M6
Ø 512 0/-0.015	Ø 512 +0.016	Ø 512 +0.109/+0.076	0.007	Ø 528	Ø 560.46	284.48	293.98	18x20°	18x M6	12x M8



Further information:

For CAD data, visit cad.heidenhain.com

ECA 4412, ECA 4492 (scale drum without centering collar)

Dimensions

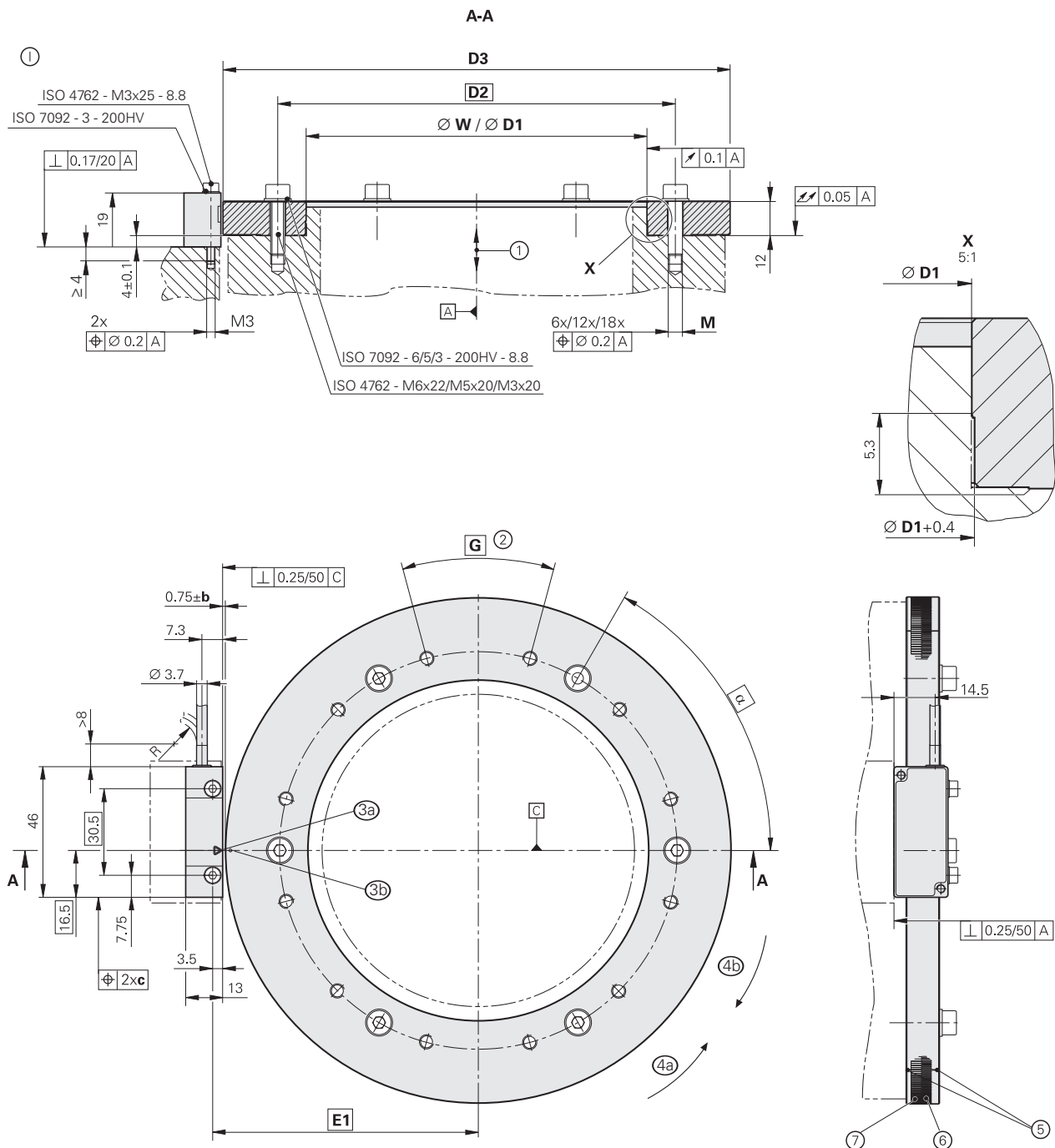

⊙, ⊕ = Mounting possibilities

⊠ = Bearing

W = Mating diameter (shaft)

1 = Permissible axial motion of the motor shaft: $\leq \pm 0.4$ mm

2 = Not permissible for drum fastening

3 = Optical center line and marking for 0° position

4a = Positive direction of rotation for scanning heads **with** functional safety

4b = Positive direction of rotation for scanning heads **without** functional safety

5 = Marking for drum centering ($3 \times 120^\circ$)

6 = Incremental track

7 = Absolute track

8 = Space for mounting aid

9 = Mounting aid

mm



Tolerancing ISO 8015

ISO 2768:1989-mH

≤ 6 mm: ± 0.2 mm

II

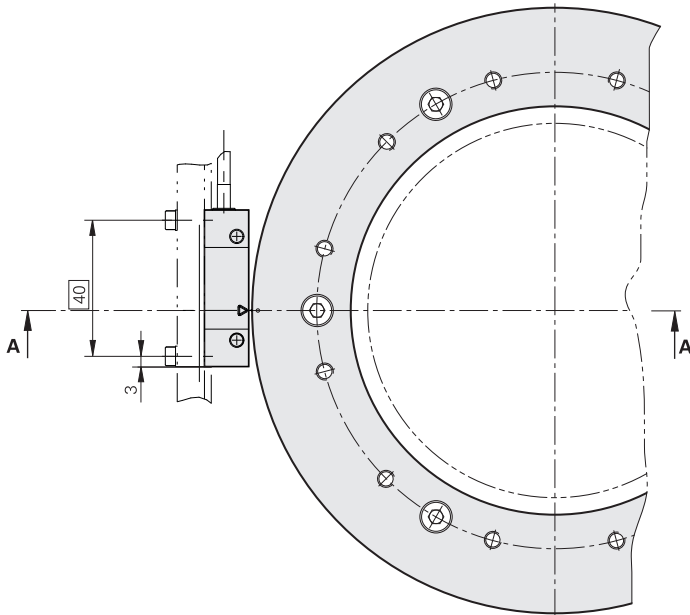
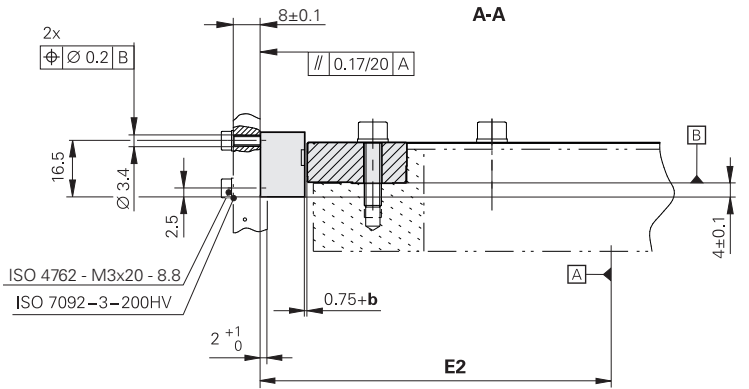

Accessory: Mounting aid

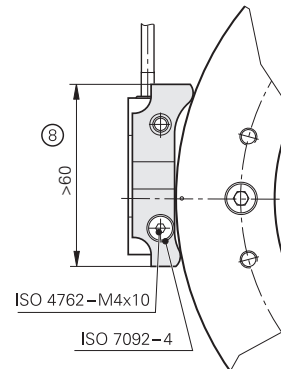
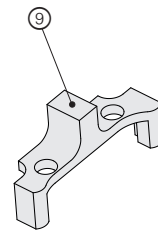
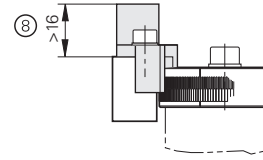

D1	W	D2	D3	E1	E2	α	M	G	b [mm]	c [mm]
$\varnothing 70$ +0.05/+0.07	$\varnothing \leq 70$	$\varnothing 85$	$\varnothing 104.63$	56.57	66.07	6x60° = 360°	6x M5	/	± 0.07	0.3
$\varnothing 80$ +0.05/+0.07	$\varnothing \leq 80$	$\varnothing 95$	$\varnothing 127.64$	68.07	77.57	6x60° = 360°	6x M5	/	± 0.07	0.3
$\varnothing 120$ +0.05/+0.07	$\varnothing \leq 120$	$\varnothing 140$	$\varnothing 178.55$	93.52	103.02	6x60° = 360°	6x M5	/	± 0.10	0.3
$\varnothing 130$ +0.05/+0.07	$\varnothing \leq 130$	$\varnothing 139$	$\varnothing 148.20$	78.35	87.85	12x30° = 360°	12x M3	/	± 0.07	0.3
$\varnothing 150$ +0.05/+0.07	$\varnothing \leq 150$	$\varnothing 163$	$\varnothing 178.55$	93.52	103.02	12x30° = 360°	12x M3	/	± 0.10	0.3
$\varnothing 150$ +0.05/+0.07	$\varnothing \leq 150$	$\varnothing 165$	$\varnothing 208.89$	108.69	118.19	6x60° = 360°	6x M5	/	± 0.12	0.5
$\varnothing 180$ +0.05/+0.07	$\varnothing \leq 180$	$\varnothing 200$	$\varnothing 254.93$	131.71	141.21	6x60° = 360°	6x M5	/	± 0.12	0.5
$\varnothing 185$ +0.05/+0.07	$\varnothing \leq 185$	$\varnothing 197$	$\varnothing 208.89$	108.69	118.19	12x30° = 360°	12x M3	/	± 0.12	0.5
$\varnothing 210$ +0.05/+0.07	$\varnothing \leq 210$	$\varnothing 230$	$\varnothing 254.93$	131.71	141.21	12x30° = 360°	12x M3	/	± 0.12	0.5
$\varnothing 270$ +0.05/+0.07	$\varnothing \leq 270$	$\varnothing 290$	$\varnothing 331.31$	169.90	179.40	12x30° = 360°	12x M5	/	± 0.15	1.0
$\varnothing 425$ +0.05/+0.07	$\varnothing \leq 425$	$\varnothing 445$	$\varnothing 484.07$	246.29	255.79	12x30° = 360°	12x M6	12x M6	± 0.15	1.0
$\varnothing 512$ +0.05/+0.07	$\varnothing \leq 512$	$\varnothing 528$	$\varnothing 560.46$	284.48	293.98	18x20° = 360°	18x M6	12x M8	± 0.15	1.0



Further information:

For CAD data, visit cad.heidenhain.com

ERA 4000 series

High-accuracy incremental angle encoder

- Steel scale drum with three-point centering or centering collar
- Optimized scanning performance for very high reliability
- Integrated three-color LED signal-quality indicator
- Consists of a scanning head and scale drum with optional sealing-air cover

Scanning head	AK ERA 4280 with 20 µm graduation period AK ERA 4480 with 40 µm graduation period AK ERA 4880 with 80 µm graduation period
Interface	~ 1 V _{PP} , HSP
Cutoff frequency -3 dB	1 MHz
Electrical connection	Cable (1 m or 3 m) 12-pin M12 coupling or 12-pin M23 coupling or 15-pin D-sub connector
Cable length	≤ 150 m (with HEIDENHAIN cable)
Supply voltage	DC 5 V ±0.5 V
Current consumption	< 130 mA (without load)
Vibration 55 Hz to 2000 Hz	With mechanical fault exclusion: ≤ 200 m/s ² (EN 60068-2-6) Without mechanical fault exclusion: ≤ 200 m/s ² (EN 60068-2-6)
Shock 11 ms 6 ms	With mechanical fault exclusion: ≤ 200 m/s ² (EN 60068-2-27) Without mechanical fault exclusion: ≤ 1000 m/s ² (EN 60068-2-27)
Operating temperature	-10 °C to 70 °C
Relative air humidity	≤ 93% (at 40 °C/4d as per EN 60068-2-78); condensation excluded
Protection	IP40
Mass	Scanning head ≈ 20 g (without cable) Connecting cable ≈ 20 g/m Coupling (M12) ≈ 15 g Coupling (M23) ≈ 50 g D-sub connector ≈ 32 g

Scanning head	AK ERA 4480 with 40 µm graduation period and sealing-air cover
Interface	~ 1 V _{PP} , HSP
Cutoff frequency -3 dB	1 MHz
Electrical connection	Cable (1 m or 3 m) 12-pin M12 coupling or 12-pin M23 coupling
Cable length	≤ 150 m (with HEIDENHAIN cable)
Supply voltage	DC 5 V ±0.5 V
Current consumption	< 130 mA (without load)
Vibration 55 Hz to 2000 Hz	With mechanical fault exclusion: ≤ 200 m/s ² (EN 60068-2-6) Without mechanical fault exclusion: ≤ 200 m/s ² (EN 60068-2-6)
Shock: 11 ms 6 ms	With mechanical fault exclusion: ≤ 200 m/s ² (EN 60068-2-27) Without mechanical fault exclusion: ≤ 1000 m/s ² (EN 60068-2-27)
Operating temperature	-10 °C to 70 °C
Relative air humidity	≤ 93% (at 40 °C/4d as per EN 60068-2-78); condensation excluded
Protection	IP40
Mass	Scanning head ≈ 35 g (without cable) Cable ≈ 20 g/m Coupling (M12) ≈ 15 g Coupling (M23) ≈ 50 g

Scanning head		AK ERA 4470				
Interface		□□TTL				
Integrated interpolation*		1-fold ¹⁾	10-fold	50-fold	100-fold	500-fold 1000-fold
Scanning frequency ²⁾		≤ 450 kHz	≤ 312.5 kHz	≤ 125 kHz	≤ 62.5 kHz	≤ 12.5 kHz ≤ 6.25 kHz
Edge separation <i>a</i>		≥ 0.220 μs	≥ 0.07 μs	≥ 0.03 μs		
Electrical connection*		Cable (1 m or 3 m) 15-pin D-sub connector (male), with interface electronics in the connector				
Cable length		With HEIDENHAIN cable: ≤ 20 m; during signal adjustment with the PWM 21: ≤ 3 m				
Supply voltage		DC 5 V ±0.5 V				
Current consumption		≤ 250 mA (without load)				
Vibration 55 Hz to 2000 Hz		With mechanical fault exclusion: ≤ 200 m/s ² (EN 60068-2-6) Without mechanical fault exclusion: ≤ 200 m/s ² (EN 60068-2-6)				
Shock 11 ms 6 ms		With mechanical fault exclusion: ≤ 200 m/s ² (EN 60068-2-27) Without mechanical fault exclusion: ≤ 1000 m/s ² (EN 60068-2-27)				
Operating temperature		-10 °C to 70 °C				
Relative air humidity		≤ 93% (at 40 °C/4d as per EN 60068-2-78); condensation excluded				
Protection		IP40				
Mass		Scanning head ≈ 20 g (without cable) Cable ≈ 20 g/m D-sub connector ≈ 74 g				

* Please select when ordering

¹⁾ Suitable for applications that measure the time between individual TTL output signal clock edges;
non-clocked output signals enable low edge jitter

²⁾ Maximum scanning frequency during referencing: 70 kHz

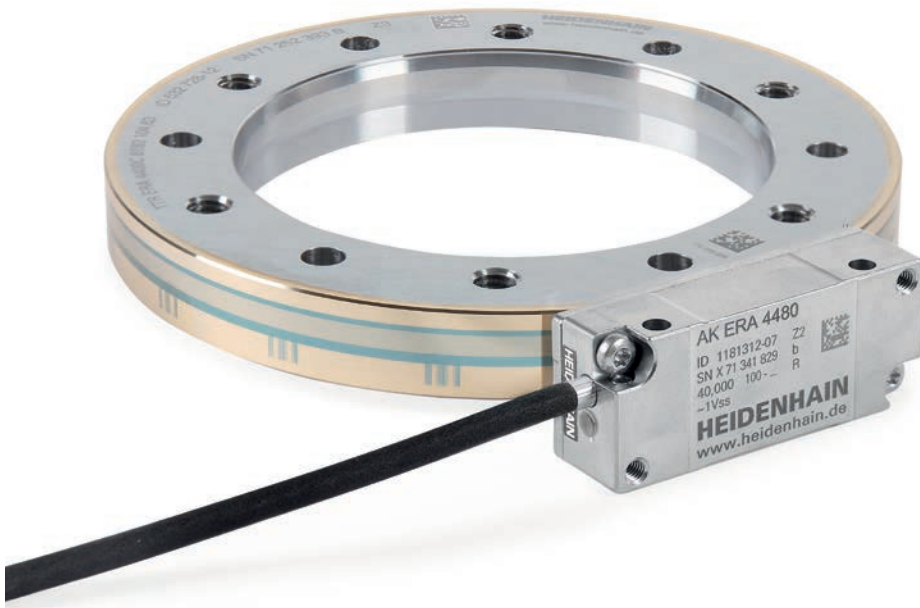

Scale drum with centering collar

Measuring standard

Coefficient of expansion

Signal periods/
interpolation error
per signal period¹⁾

TTR ERA 4200

TTR ERA 4400

TTR ERA 4800

Accuracy of graduation

Reference marks

Drum inside diameter*

Drum outside diameter*

Mech. permissible speed

With mechanical fault exclusion

Without mechanical fault exclusion

Moment of inertia

Maximum angular acceleration with
mechanical fault exclusion

Permissible axial movement

Protection EN 60529

Mass

TTR ERA 4200C with 20 µm graduation period TTR ERA 4400C with 40 µm graduation period TTR ERA 4800C with 80 µm graduation period									
Steel drum $\alpha_{\text{therm}} \approx 10.4 \cdot 10^{-6} \text{ K}^{-1}$									
12000/ $\pm 0.32''$	16384/ $\pm 0.24''$	20000/ $\pm 0.19''$	28000/ $\pm 0.14''$	32768/ $\pm 0.12''$	40000/ $\pm 0.10''$	52000/ $\pm 0.07''$	–	–	–
6000/ $\pm 1.08''$	8192/ $\pm 0.79''$	10000/ $\pm 0.65''$	14000/ $\pm 0.46''$	16384/ $\pm 0.40''$	20000/ $\pm 0.32''$	26000/ $\pm 0.25''$	38000/ $\pm 0.17''$	44000/ $\pm 0.15''$	–
3000/ $\pm 2.16''$	4096/ $\pm 1.58''$	5000/ $\pm 1.30''$	7000/ $\pm 0.93''$	8192/ $\pm 0.79''$	10000/ $\pm 0.65''$	13000/ $\pm 0.50''$	–	–	–
$\pm 5''$	$\pm 3.7''$	$\pm 3''$	$\pm 2.5''$				$\pm 2''$		
Distance-coded or one									
40 mm	70 mm	80 mm	120 mm	150 mm	180 mm	270 mm	425 mm	512 mm	–
76.75 mm	104.63 mm	127.64 mm	178.55 mm	208.89 mm	254.93 mm	331.31 mm	484.07 mm	560.46 mm	–
10000 rpm	8500 rpm	6250 rpm	4500 rpm	4250 rpm	3250 rpm	2500 rpm	1800 rpm	1500 rpm	–
20000 rpm	15000 rpm	12250 rpm	8750 rpm	7500 rpm	6250 rpm	4750 rpm	3250 rpm	2750 rpm	–
$0.27 \cdot 10^{-3} \text{ kgm}^2$	$0.81 \cdot 10^{-3} \text{ kgm}^2$	$1.9 \cdot 10^{-3} \text{ kgm}^2$	$7.1 \cdot 10^{-3} \text{ kgm}^2$	$12 \cdot 10^{-3} \text{ kgm}^2$	$28 \cdot 10^{-3} \text{ kgm}^2$	$59 \cdot 10^{-3} \text{ kgm}^2$	$195 \cdot 10^{-3} \text{ kgm}^2$	$258 \cdot 10^{-3} \text{ kgm}^2$	–
20000 rad/s ²	14000 rad/s ²	6600 rad/s ²	2700 rad/s ²	1800 rad/s ²	1000 rad/s ²	1300 rad/s ²	900 rad/s ²	1200 rad/s ²	–
$\leq \pm 0.5 \text{ mm}$ (scale drum relative to the scanning head)									
Complete encoder after mounting: IP00; with sealing-air cover: IP40									
$\approx 0.28 \text{ kg}$	$\approx 0.41 \text{ kg}$	$\approx 0.68 \text{ kg}$	$\approx 1.2 \text{ kg}$	$\approx 1.5 \text{ kg}$	$\approx 2.3 \text{ kg}$	$\approx 2.6 \text{ kg}$	$\approx 3.8 \text{ kg}$	$\approx 3.6 \text{ kg}$	–

* Please select when ordering

¹⁾ The interpolation error within one signal period and the accuracy of the graduation together yield the encoder-specific error; for additional errors arising from installation and the bearing of the measured shaft, see *Measurement accuracy*

Scale drum with three-point centering	TTR ERA 4202 C with 20 µm graduation period						
Measuring standard Coefficient of expansion	Steel drum $\alpha_{\text{therm}} \approx 10.4 \cdot 10^{-6} \text{ K}^{-1}$						
Signal periods	12000	16384	20000	28000	32768	40000	52000
Accuracy of graduation	±4"	±3"	±2.5"	±2"	±1.9"	±1.8"	±1.7"
Interpolation error per signal period¹⁾	±0.36"	±0.24"	±0.19"	±0.14"	±0.12"	±0.10"	±0.07"
Reference marks	Distance-coded or one						
Drum inside diameter*	40 mm	70 mm	80 mm	120 mm/ 150 mm	150 mm/ 185 mm	180 mm/ 210 mm	270 mm
Drum outside diameter*	76.75 mm	104.63 mm	127.64 mm	178.55 mm	208.89 mm	254.93 mm	331.31 mm
Mech. permissible speed	20000 rpm	15000 rpm	12250 rpm	8750 rpm	7500 rpm	6250 rpm	4750 rpm
Moment of inertia	$0.28 \cdot 10^{-3}$ kgm ²	$0.83 \cdot 10^{-3}$ kgm ²	$2.0 \cdot 10^{-3}$ kgm ²	$7.1 \cdot 10^{-3}$ kgm ² / $4.5 \cdot 10^{-3}$ kgm ²	$12 \cdot 10^{-3}$ kgm ² / $6.4 \cdot 10^{-3}$ kgm ²	$28 \cdot 10^{-3}$ kgm ² / $20 \cdot 10^{-3}$ kgm ²	$59 \cdot 10^{-3}$ kgm ²
Permissible axial movement	≤ ±0.5 mm (scale drum relative to the scanning head)						
Protection EN 60529	Complete encoder after mounting: IP00, with sealing-air cover: IP40						
Mass	≈ 0.30 kg	≈ 0.42 kg	≈ 0.69 kg	≈ 1.2 kg/ ≈ 0.66 kg	≈ 1.5 kg/ ≈ 0.66 kg	≈ 2.3 kg/ ≈ 1.5 kg	≈ 2.6 kg

* Please select when ordering

¹⁾ The interpolation error within one signal period and the accuracy of the graduation together yield the encoder-specific error; for additional errors arising from installation and the bearing of the measured shaft, see *Measurement accuracy*

ERA 4280C, ERA 4480C, ERA 4880C

Dimensions

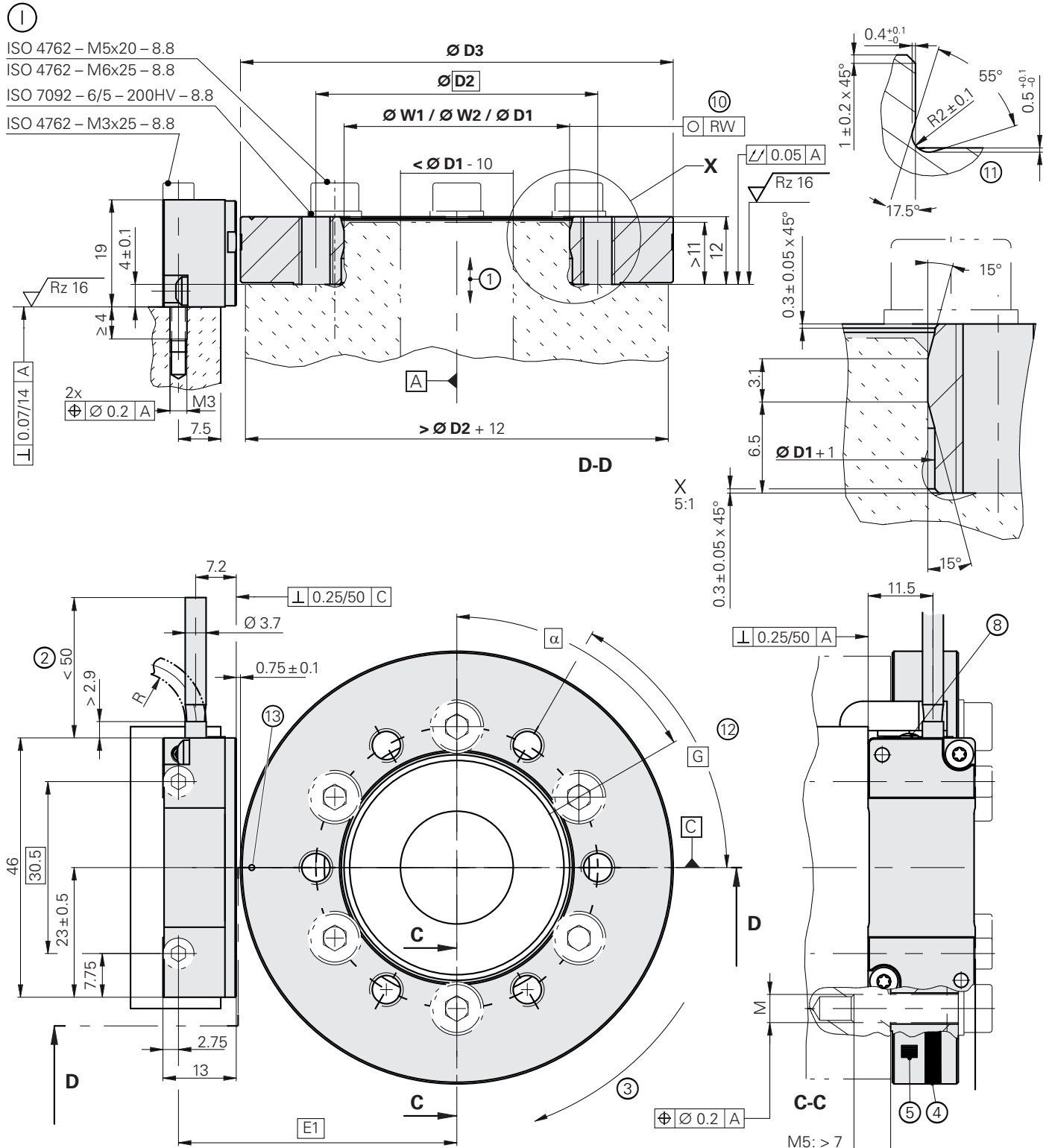

mm
 Tolerancing ISO 8015
 ISO 2768:1989-mH
 ≤ 6 mm: ±0.2 mm

W1 = Without mechanical fault exclusion
W2 = With mechanical fault exclusion

- ①, ⑩ = Mounting possibilities
- ⊠ = Bearing of mating shaft
- W = Mating diameter (shaft)
- 1 = Permissible axial motion of the motor shaft: ≤ ±0.5 mm
- 2 = Cable support
- 3 = Positive direction of rotation
- 4 = Incremental track
- 5 = Reference pulse track
- 6 = Space for mounting aid
- 7 = With mechanical fault exclusion: a = 11.5 mm ±0.1 mm
- 8 = Signal-quality indicator
- 9 = Mounting aid (accessory)
- 10 = Roundness of mating diameter (shaft)
- 11 = Proposed design for undercut
- 12 = Back-off thread; not permitted for drum fastening

II

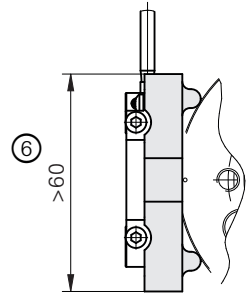
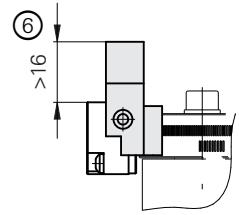
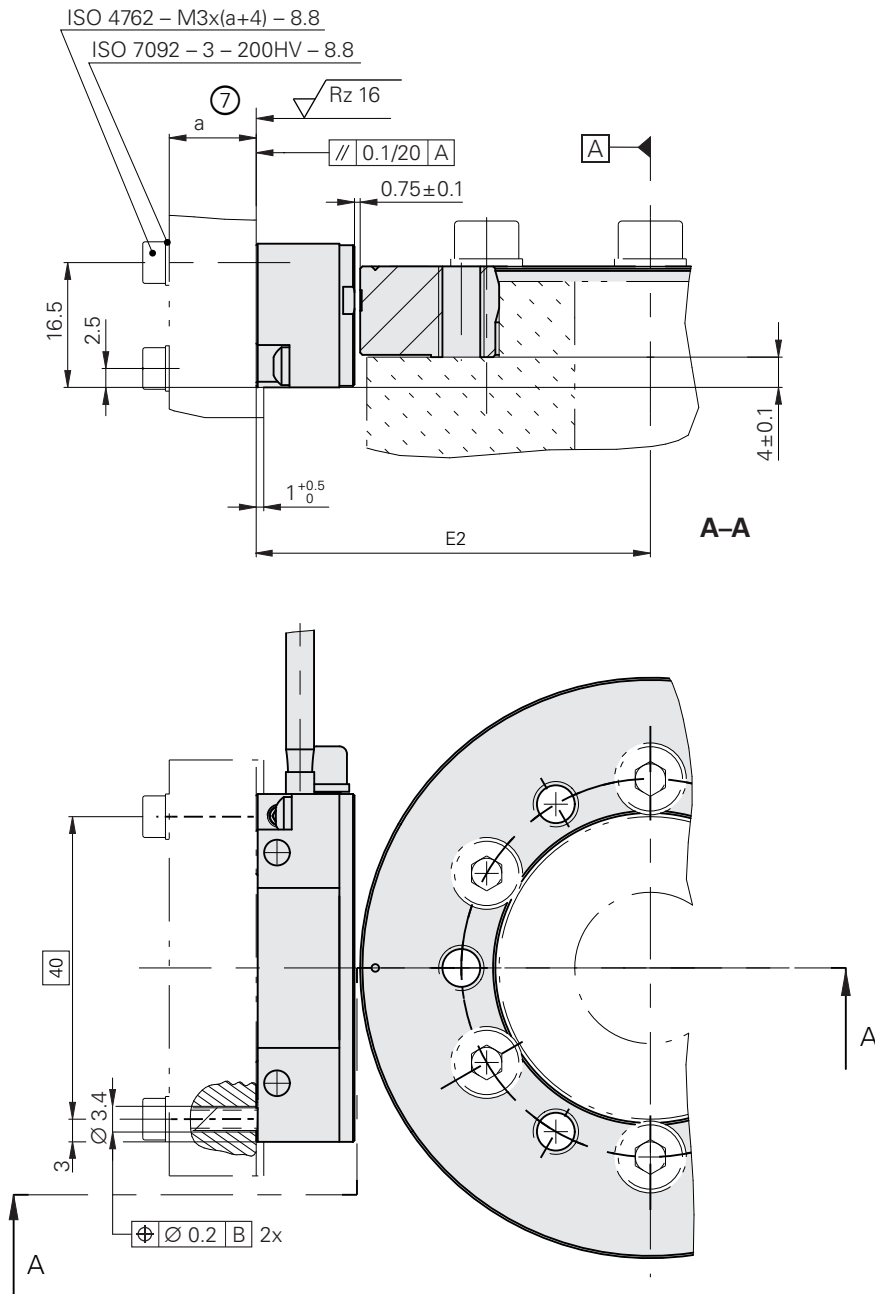

1:1

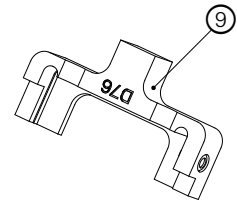

1:1

D1	W1	W2	RW	D2	D3	E1	E2	α	M	G
Ø 40 -0.001/-0.005	Ø 40 +0.004	Ø 40 +0.004/+0.000	0.001	Ø 50	Ø 76.75	49.38	52.13	6x60°	6x M5	6x M6
Ø 70 -0.001/-0.005	Ø 70 +0.005	Ø 70 +0.007/+0.002	0.001	Ø 85	Ø 104.63	63.32	66.07	6x60°	6x M5	6x M6
Ø 80 -0.001/-0.005	Ø 80 +0.006	Ø 80 +0.009/+0.003	0.0015	Ø 95	Ø 127.64	74.82	77.57	6x60°	6x M5	6x M6
Ø 120 -0.001/-0.008	Ø 120 +0.008	Ø 120 +0.040/+0.022	0.002	Ø 140	Ø 178.55	100.27	103.02	6x60°	6x M5	6x M6
Ø 150 -0.001/-0.008	Ø 150 +0.008	Ø 150 +0.046/+0.028	0.002	Ø 165	Ø 208.89	115.44	118.19	6x60°	6x M5	6x M6
Ø 180 -0.001/-0.008	Ø 180 +0.010	Ø 180 +0.050/+0.030	0.003	Ø 200	Ø 229.46	125.73	128.48	6x60°	6x M5	6x M6
Ø 180 -0.001/-0.008	Ø 180 +0.010	Ø 180 +0.050/+0.030	0.003	Ø 200	Ø 254.93	138.46	141.21	6x60°	6x M5	6x M6
Ø 270 0/-0.01	Ø 270 +0.012	Ø 270 +0.067/+0.044	0.003	Ø 290	Ø 331.31	176.65	179.40	12x30°	12x M5	12x M6
Ø 425 0/-0.01	Ø 425 +0.015	Ø 425 +0.094/+0.067	0.006	Ø 445	Ø 484.07	253.04	255.79	12x30°	12x M6	12x M6
Ø 512 0/-0.015	Ø 512 +0.016	Ø 512 +0.109/+0.076	0.007	Ø 528	Ø 560.46	291.23	293.98	18x20°	18x M6	12x M8

ERA 4202C

Dimensions



ISO 4762 – M3x20 – 8.8
ISO 4762 – M5x20 – 8.8

ISO 7092 – 5/3 – 200HV – 8.8

ISO 4762 – M3x25 – 8.8

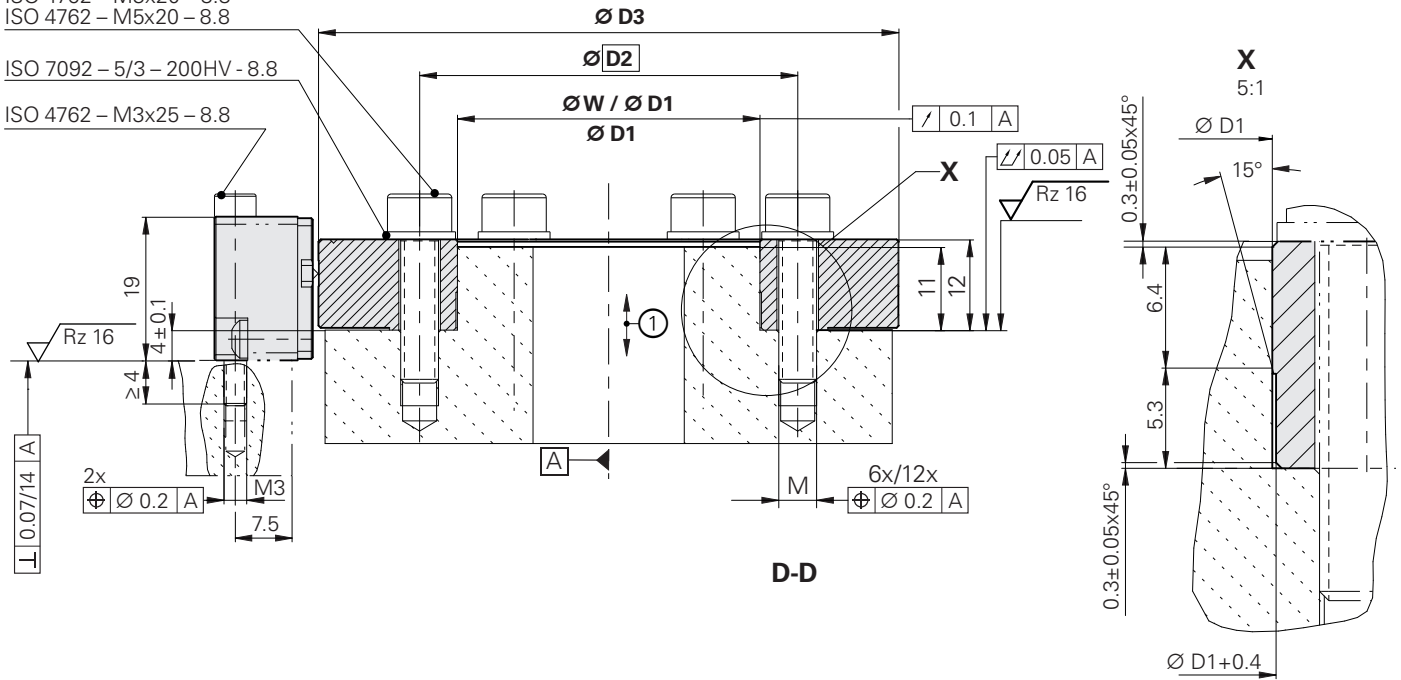

D-D

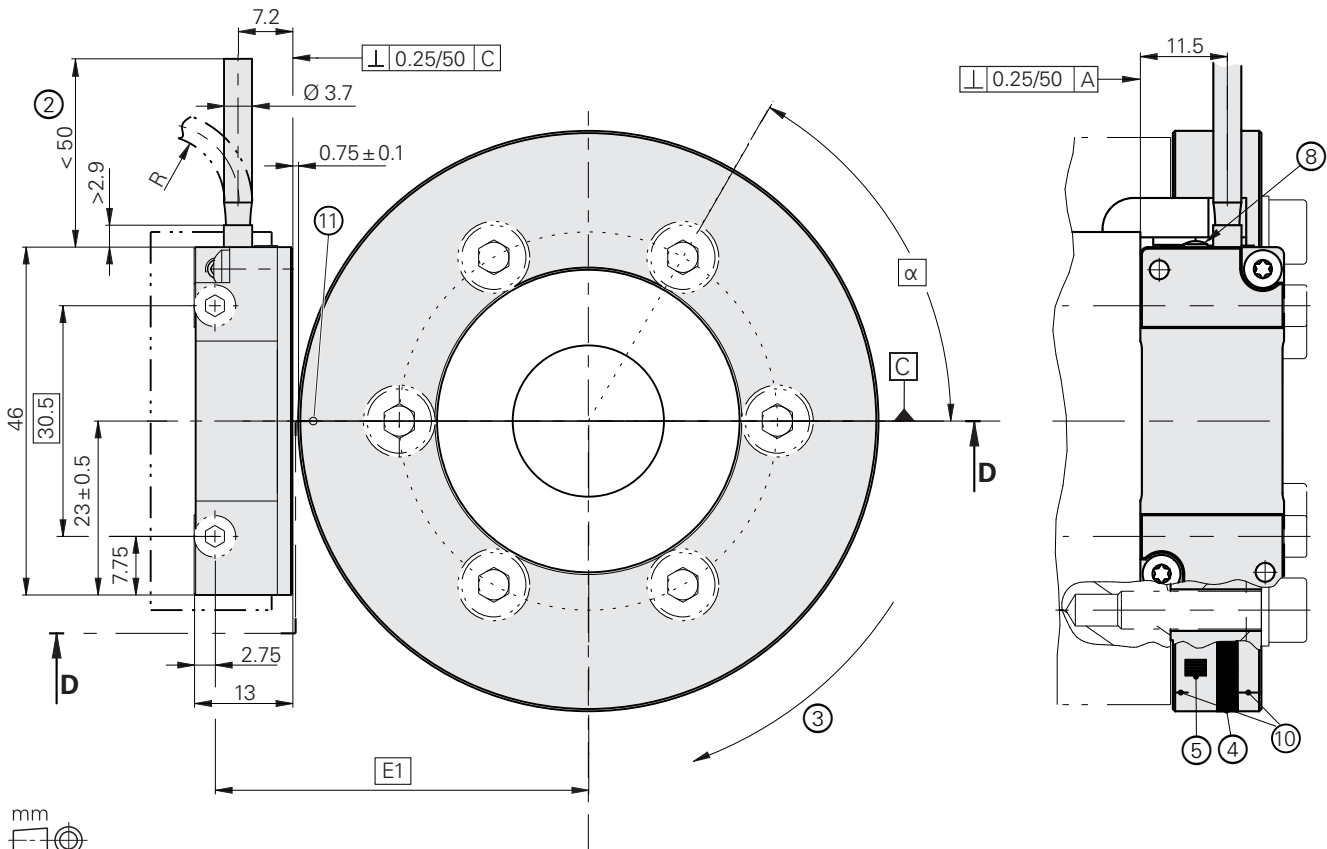

mm

Tolerancing ISO 8015
ISO 2768:1989-mH
≤ 6 mm: ±0.2 mm

⊙, ⊕ = Mounting possibilities

⊠ = Bearing of mating shaft

W = Mating diameter (shaft)

1 = Permissible axial motion of the motor shaft:
≤ ±0.5 mm

2 = Cable support

3 = Positive direction of rotation

4 = Incremental track

5 = Reference pulse track

6 = Space for mounting aid

7 = With mechanical fault exclusion

a = 11.5 mm ±0.1 mm

8 = Signal-quality indicator

9 = Mounting aid (accessory)

10 = Marking for drum centering (3x120°)

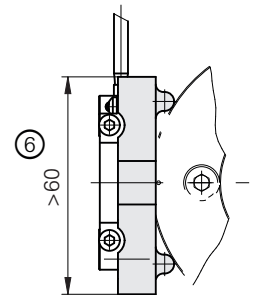
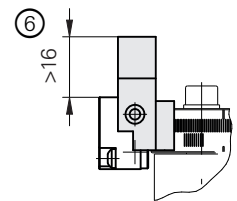
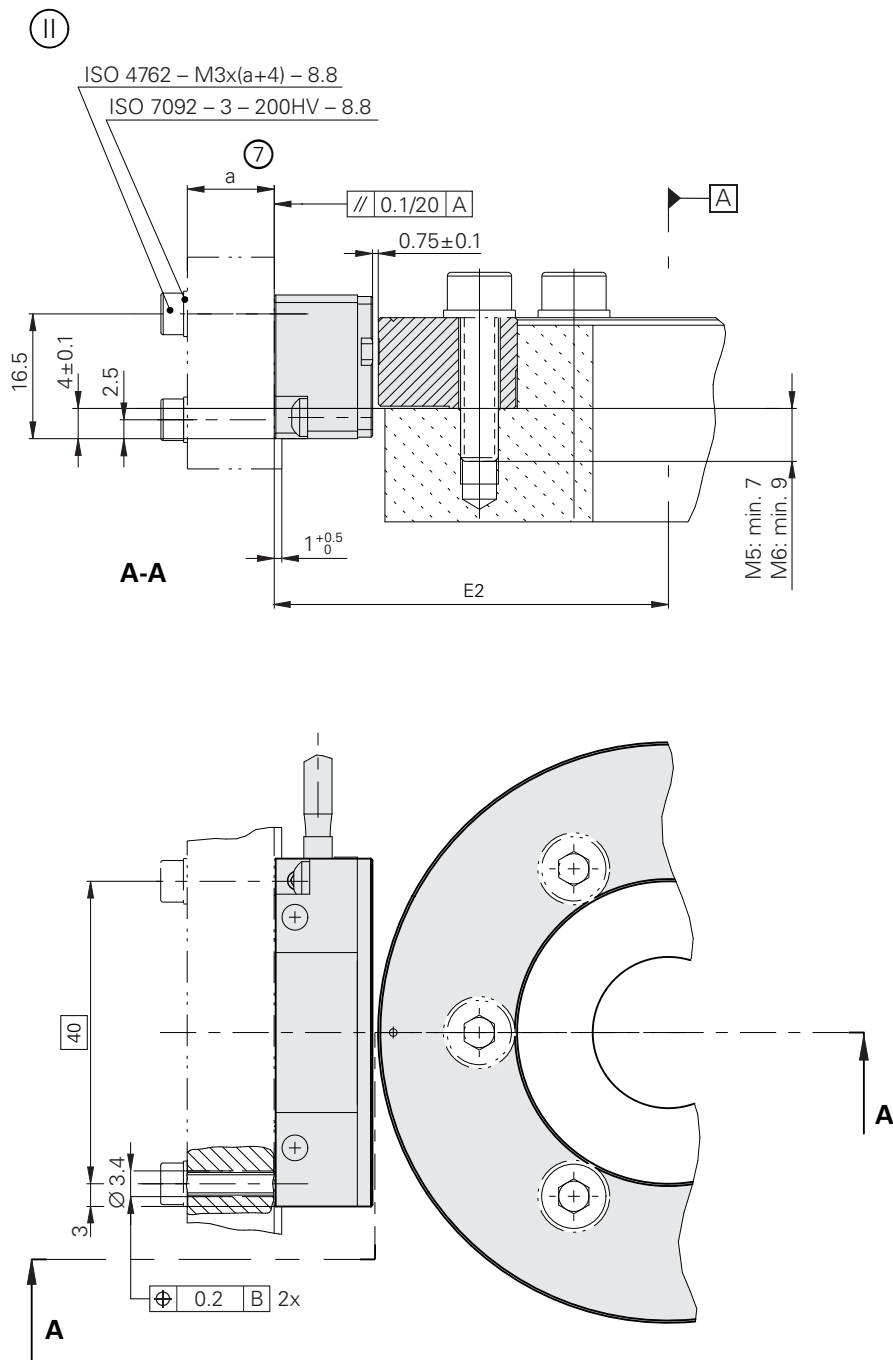

1:1

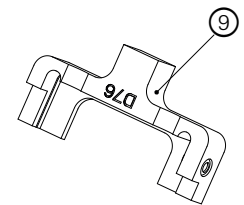

1:1

D1	W	D2	D3	E1	E2	α	M
Ø 40 +0.05/+0.07	Ø ≤40	Ø 50	Ø 76.75	49.38	52.13	6x60°	6x M5
Ø 70 +0.05/+0.07	Ø ≤70	Ø 85	Ø 104.63	63.32	66.07	6x60°	6x M5
Ø 80 +0.05/+0.07	Ø ≤80	Ø 95	Ø 127.64	74.82	77.57	6x60°	6x M5
Ø 120 +0.05/+0.07	Ø ≤120	Ø 140	Ø 178.55	100.27	103.02	6x60°	6x M5
Ø 150 +0.05/+0.07	Ø ≤150	Ø 165	Ø 208.89	115.44	118.19	6x60°	6x M5
Ø 180 +0.05/+0.07	Ø ≤180	Ø 200	Ø 254.93	138.46	141.21	6x60°	6x M5
Ø 185 +0.05/+0.07	Ø ≤185	Ø 197	Ø 208.89	115.44	118.19	12x30°	12x M3
Ø 150 +0.05/+0.07	Ø ≤150	Ø 163	Ø 178.55	100.27	103.02	12x30°	12x M3
Ø 210 +0.05/+0.07	Ø ≤210	Ø 230	Ø 254.93	138.46	141.21	12x30°	12x M3
Ø 270 +0.05/+0.07	Ø ≤270	Ø 290	Ø 331.31	176.65	179.40	12x30°	12x M5

ERA 4480C

With sealing-air cover

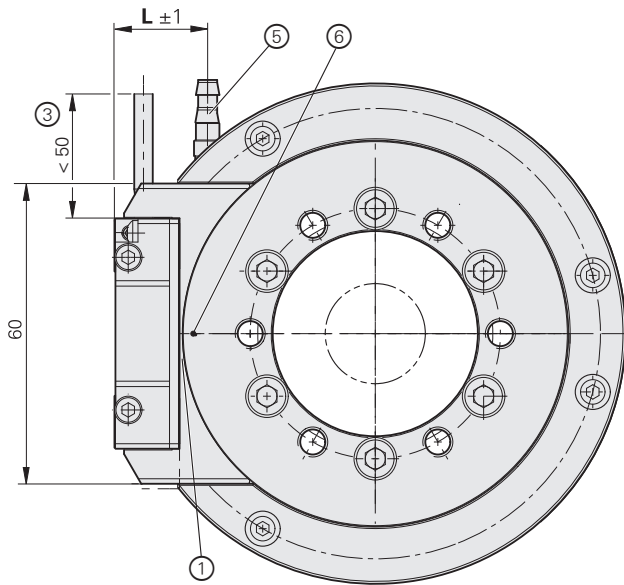
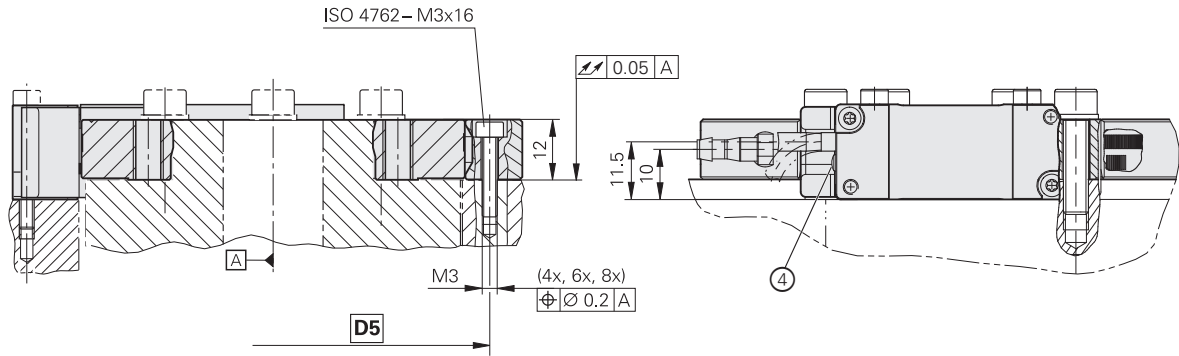

- Ⓐ ... Ⓒ = Sealing-air cover version
- Ⓐ = Bearing
- 1 = Mounting clearance: 0.15 mm (scanning head)
- 2 = Mounting clearance: 0.15 mm (sealing-air cover)
- 3 = Cable support
- 4 = Signal-quality indicator
- 5 = Sealing-air connecting piece
- 6 = Reference mark position

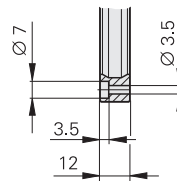
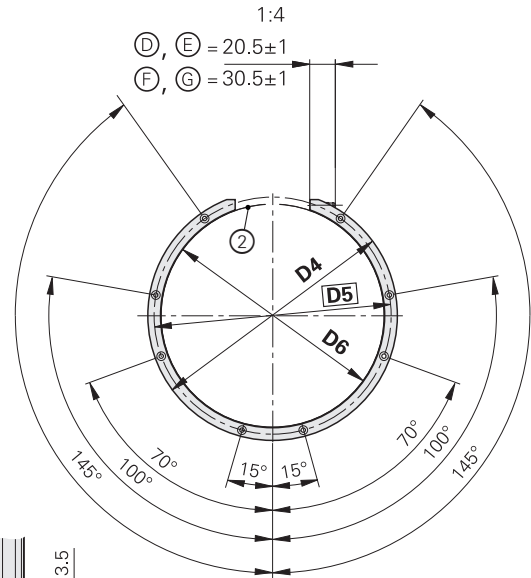
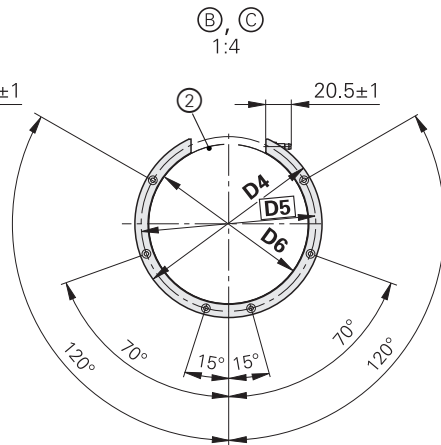
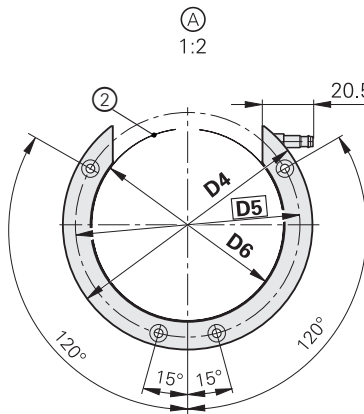

	D3	D4	D5	D6	L
Ⓐ	∅ 76.75	∅ 100	∅ 90	∅ 77.2	18.6
Ⓑ	∅ 104.63	∅ 127	∅ 117	∅ 105.2	16.5
Ⓒ	∅ 127.64	∅ 150	∅ 140	∅ 128.2	15.5
Ⓓ	∅ 178.55	∅ 200	∅ 190	∅ 179.1	14.5
Ⓔ	∅ 208.89	∅ 232	∅ 222	∅ 209.4	13.2
Ⓕ	∅ 254.93	∅ 278	∅ 268	∅ 255.6	12.7
Ⓖ	∅ 331.31	∅ 354	∅ 344	∅ 332	12.1



Further information:

For CAD data, visit cad.heidenhain.com

ECM 2400 series

Absolute angle encoder with magnetic scanning

- Consists of a scanning head and scale drum
- Also for safety-related applications
- Resistant to contamination



Scanning head

Interface

Ordering designation

Clock frequency

Calculation time t_{cal}

Functional safety

for applications with up to

PFH

Electrical connection

Cable length¹⁾

Supply voltage

Power consumption (max.)

Current consumption (typical)

Vibration 55 Hz to 2000 Hz

Shock 6 ms

With mechanical fault exclusion

Without mechanical fault exclusion

Operating temperature

Protection EN 60529

Mass Scanning head
Cable
M23 coupling

¹⁾ With HEIDENHAIN cable;
clock frequency ≤ 8 MHz

	AK ECM 2410 	AK ECM 2490 F	AK ECM 2490 M
	EnDat 2.2	Fanuc Serial Interface; α i Interface	Mitsubishi high speed interface
	EnDat22	Fanuc05	Mit03-4
	≤ 16 MHz	–	
	≤ 5 μ s	–	
	<ul style="list-style-type: none"> • SIL 2 as per EN 61508 (further basis for testing: IEC 61800-5-3) • Category 3, PL "d" as per EN ISO 13849-1:2015 	–	
	$\leq 25 \cdot 10^{-9}$ (up to 6000 m above sea level)	–	
	Cable (1 m) with 8-pin M12 coupling (male)		
	≤ 30 m		
	DC 3.6V to 14 V		
	At 3.6 V: 1.1 W At 14 V: 1.3 W		
	At 5 V: < 200 mA (without load)		
	≤ 400 m/s ² (EN 60068-2-6) ≤ 400 m/s ² (EN 60068-2-27) ≤ 1000 m/s ² (EN 60068-2-27)		
	–10 °C to 80 °C		
	IP67		
	≈ 40 g (without cable) ≈ 35 g/m ≈ 15 g		

Scale drum	TTR ECM 2400 with a graduation period $\approx 400 \mu\text{m}$		
Measuring standard Coefficient of expansion	Steel drum $\alpha_{\text{therm}} \approx 10 \cdot 10^{-6} \text{ K}^{-1}$		
Signal periods	900	1024	1200
Drum inside diameter*	70 mm	80 mm/95 mm	105 mm/120 mm
Drum outside diameter*	113.16 mm	128.75 mm	150.88 mm
Accuracy of graduation	$\pm 8''$	$\pm 7''$	$\pm 6''/\pm 8''$
Interpolation error per signal period	$\pm 9''$	$\pm 8''$	$\pm 7''$
Positions per revolution	8 388 608 (23 bits)	16 777 216 (24 bits)	
Measuring step	0.154''	0.077''	
Safety-relevant measuring step	0.7° (9 bits)	0.35° (10 bits)	
Safe position ^{1) 2)}	1.76°	0.88°	
Mech. permissible speed	$\leq 14\,500 \text{ rpm}$	$\leq 13\,000 \text{ rpm}/$ $\leq 12\,500 \text{ rpm}$	$\leq 10\,500 \text{ rpm}$
Max. angular acceleration	9000 rad/s^2	$6000 \text{ rad/s}^2/$ 9000 rad/s^2	$4900 \text{ rad/s}^2/$ 7000 rad/s^2
Electrically permissible shaft speed	$\leq 29\,000 \text{ rpm}$	$\leq 25\,000 \text{ rpm}$	$\leq 21\,500 \text{ rpm}$
Moment of inertia	$1.5 \cdot 10^{-3} \text{ kgm}^2$	$2.6 \cdot 10^{-3} \text{ kgm}^2/$ $2.1 \cdot 10^{-3} \text{ kgm}^2$	$4.4 \cdot 10^{-3} \text{ kgm}^2/$ $3.4 \cdot 10^{-3} \text{ kgm}^2$
Permissible axial movement	$\leq \pm 0.75 \text{ mm}$		
Mass	$\approx 0.69 \text{ kg}$	$\approx 0.89 \text{ kg}/$ $\approx 0.65 \text{ kg}$	$\approx 1.0 \text{ kg}/$ $\approx 0.72 \text{ kg}$

* Please select when ordering

1) Further deviations may arise in the downstream electronics after position value comparison (contact mfr. of the downstream electronics)

2) Mechanical coupling: for fault exclusion for the loosening of the scanning head and scale drum, see *Functional safety*

	1400	1696	2048	2600
	130 mm	160 mm	180 mm	260 mm
	176.03 mm	213.24 mm	257.50 mm	326.90 mm
	±5.5"	±4.5"	±4"	±3.5"
	±6"	±5"	±4"	±3"
	33 554 432 (25 bits)			
	0.039"			
	0.18° (11 bits)			
	0.44°			
	≤ 9000 rpm	≤ 7000 rpm	≤ 6000 rpm	≤ 4500 rpm
	3300 rad/s ²	1900 rad/s ²	820 rad/s ²	560 rad/s ²
	≤ 18500 rpm	≤ 15000 rpm	≤ 12500 rpm	≤ 10000 rpm
	74 · 10 ⁻³ kgm ²	16 · 10 ⁻³ kgm ²	37 · 10 ⁻³ kgm ²	76 · 10 ⁻³ kgm ²
	≈ 1.2 kg	≈ 1.8 kg	≈ 3.0 kg	≈ 3.5 kg

ECM 2400

Dimensions

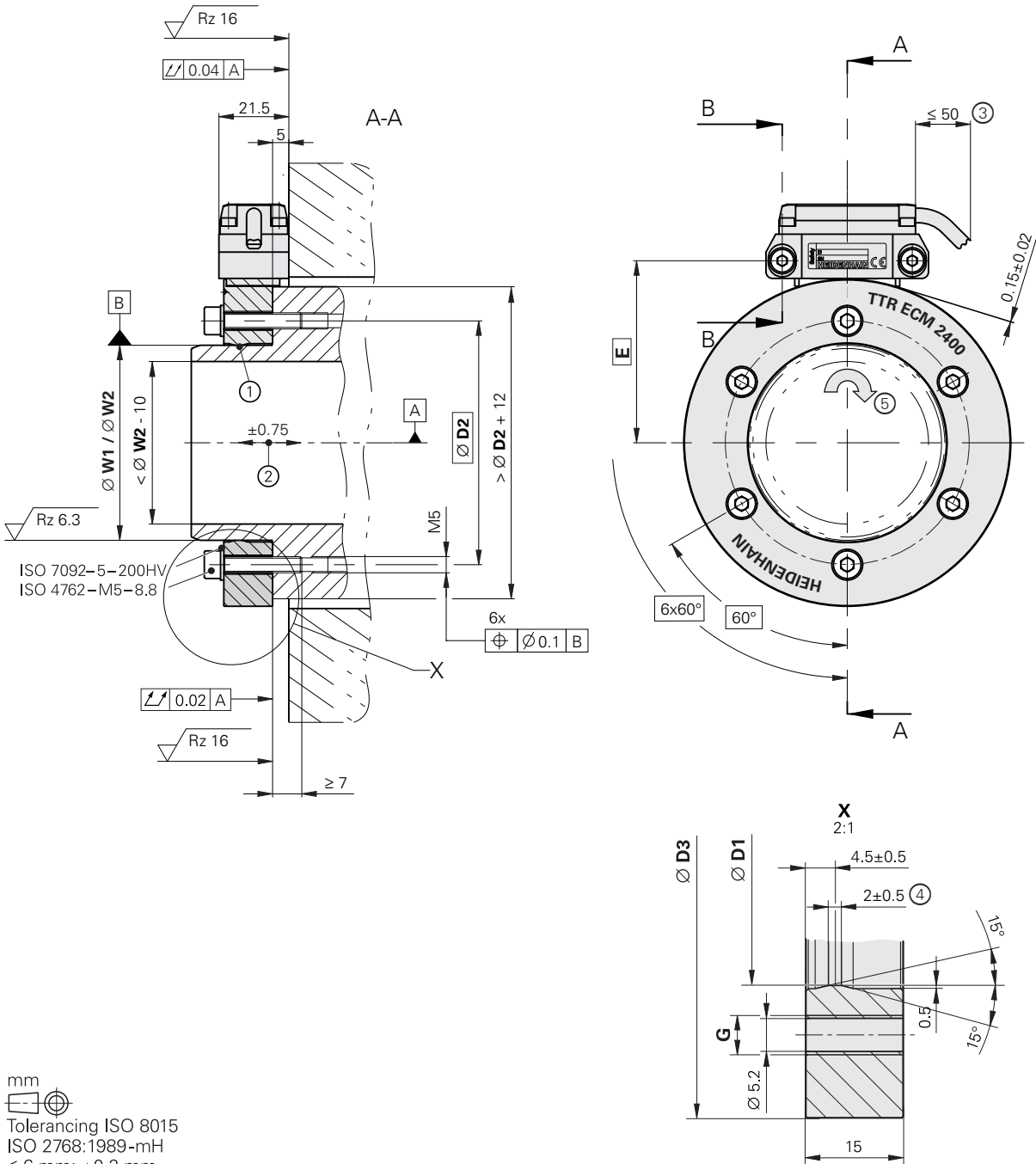

W1 = Without mechanical fault exclusion
W2 = With mechanical fault exclusion

- ☐ = Bearing of mating shaft
- 1 = Shaft fit; ensure full-surface contact
- 2 = Axial tolerance of mating shaft
- 3 = Cable support
- 4 = Centering collar
- 5 = Direction of shaft rotation for ascending position values

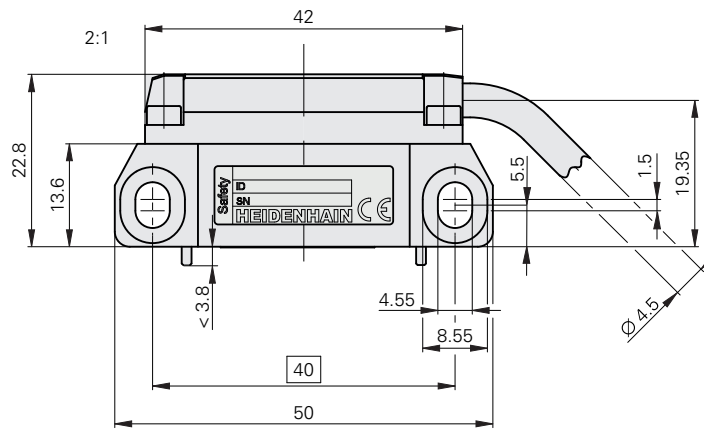
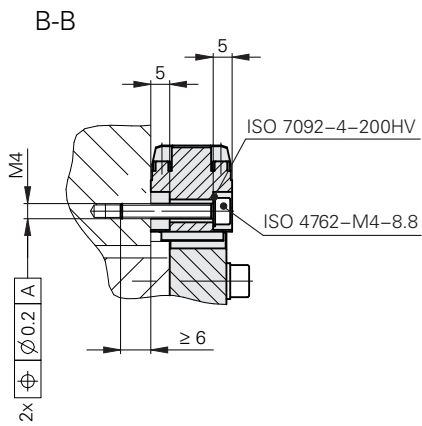

	D1	W1	W2	D2	D3	E	G
TTR ECM 2400	Ø 70 +0/-0.008	Ø 70 +0.010/+0.002	Ø 70 +0.019/+0.011	Ø 85	Ø 113.16	62.3	6x M6
	Ø 80 +0/-0.008	Ø 80 +0.010/+0.002	Ø 80 +0.022/+0.014	Ø 95	Ø 128.75	70.1	6x M6
	Ø 95 +0/-0.010	Ø 95 +0.013/+0.003	Ø 95 +0.029/+0.019	Ø 110	Ø 128.75	70.1	6x M6
	Ø 105 +0/-0.010	Ø 105 +0.013/+0.003	Ø 105 +0.031/+0.021	Ø 120	Ø 150.88	81.2	6x M6
	Ø 130 +0/-0.012	Ø 130 +0.015/+0.003	Ø 130 +0.041/+0.029	Ø 145	Ø 176.03	93.7	6x M6
	Ø 160 +0/-0.012	Ø 160 +0.015/+0.003	Ø 160 +0.049/+0.037	Ø 175	Ø 213.24	112.3	6x M6
	Ø 180 +0/-0.012	Ø 180 +0.015/+0.003	Ø 180 +0.055/+0.043	Ø 195	Ø 257.50	134.5	6x M6
	Ø 260 +0/-0.016	Ø 260 +0.020/+0.004	Ø 260 +0.082/+0.066	Ø 275	Ø 326.90	169.2	6x M6

ERM 2200/2400/2900 series

Incremental angle encoder with magnetic scanning

- Consists of a scanning head and scale drum
- Multiple graduation periods in accordance with accuracy and speed requirements
- Various drum shapes for rotary axes and main spindles
- High variety of drum diameters



ERM 2200



ERM 2900

Scanning head

Interface

Cutoff frequency (-3dB)
Scanning frequency

Integrated interpolation

Clock frequency

Calculation time t_{cal}

Electrical connection

Cable outlet

Supply voltage

Current consumption (typical)

Power consumption (max.)

Cable length¹⁾

Vibration 55 Hz to 2000 Hz

Shock 6 ms

Shock: 6 ms, With fault exclusion for the loosening of the mechanical connection

Operating temperature

Protection EN 60529

Mass Scanning head
Cable
M23 coupling
M12 coupling

Graduation period $\approx 200 \mu\text{m}$			Graduation period $\approx 400 \mu\text{m}$			Graduation period $\approx 1000 \mu\text{m}$
AK ERM 2280	AK ERM 2283	AK ERM 2293 M	AK ERM 2480	AK ERM 2420	AK ERM 2410	AK ERM 2980
$\sim 1 V_{PP}$		Mitsubishi high speed Interface (Mit 02-4) ²⁾	$\sim 1 V_{PP}$	TTL x 1, TTL x 2	EnDat 2.2 ^{2) 3)}	$\sim 1 V_{PP}$
$\geq 300 \text{ kHz}$ –	– –	– –	$\geq 300 \text{ kHz}$ –	– $\geq 350 \text{ kHz}$	– –	$\geq 300 \text{ kHz}$ –
–		16384 (14 bits)	–		16384 (14 bits)	–
–					$\leq 8 \text{ MHz}$	–
–					$\leq 5 \mu\text{s}$	–
Cable (1 m) with or without 12-pin M23 coupling	Cable (1 m) with 12-pin M23 coupling or 12-pin M12 coupling	Cable (1 m) with 8-pin M12 coupling	Cable (1 m) with or without 12-pin M23 coupling		Cable (1 m) with 8-pin M12 coupling	Cable (1 m) with or without 12-pin M23 coupling
Tangential, to the left or right			Tangential, to the left or right, axial		Tangential, to the right	Tangential, to the left or right, axial
DC 5 V ± 0.5 V		DC 3.6 V to 14 V	DC 5 V ± 0.5 V		DC 3.6 V to 14 V	DC 5 V ± 0.5 V
$\leq 150 \text{ mA}$ (without load)	$\leq 35 \text{ mA}$ (without load)	$\leq 90 \text{ mA}$ (without load)	$\leq 150 \text{ mA}$ (without load)		At 5 V: $\leq 90 \text{ mA}$ (without load)	$\leq 150 \text{ mA}$ (without load)
–		At 3.6 V: 1080 mW At 14 V: 1300 mW	–		At 3.6 V: 1080 mW At 14 V: 1300 mW	–
$\leq 150 \text{ m}$		$\leq 30 \text{ m}$	$\leq 150 \text{ m}$	$\leq 100 \text{ m}$	$\leq 150 \text{ m}$	
$\leq 400 \text{ m/s}^2$ (EN 60068-2-6)	$\leq 1000 \text{ m/s}^2$ (EN 60068-2-27)	$\leq 400 \text{ m/s}^2$ (EN 60068-2-6) $\leq 1000 \text{ m/s}^2$ (EN 60068-2-27) $\leq 400 \text{ m/s}^2$ (EN 60068-2-27)	$\leq 400 \text{ m/s}^2$ (EN 60068-2-6) $\leq 1000 \text{ m/s}^2$ (EN 60068-2-27) $\leq 400 \text{ m/s}^2$ (EN 60068-2-27)		$\leq 300 \text{ m/s}^2$ (EN 60068-2-6) $\leq 1000 \text{ m/s}^2$ (EN 60068-2-27) $\leq 400 \text{ m/s}^2$ (EN 60068-2-27)	$\leq 400 \text{ m/s}^2$ (EN 60068-2-6) $\leq 1000 \text{ m/s}^2$ (EN 60068-2-27) $\leq 400 \text{ m/s}^2$ (EN 60068-2-27)
–10 °C to 60 °C			–10 °C to 100 °C			
IP67						
$\approx 30 \text{ g}$ (without cable) $\approx 37 \text{ g/m}$ $\approx 50 \text{ g}$ $\approx 15 \text{ g}$						

¹⁾ With HEIDENHAIN cable

²⁾ Absolute position value after crossing two reference marks

³⁾ EnDat 2.2 for incremental encoders can be used only after consultation with the controller manufacturer

Scale drum	TTR ERM 2200 TTR ERM 2203 Grating period $\approx 200 \mu\text{m}$				
Measuring standard Coefficient of expansion	Steel drum $\alpha_{\text{therm}} \approx 10 \cdot 10^{-6} \text{ K}^{-1}$				
Signal periods	1024	1200	1440	1800	2048
Drum inside diameter*	40 mm	40 mm/55 mm	55 mm	70 mm	80 mm/95 mm
Drum outside diameter*	64.37 mm	75.44 mm	90.53 mm	113.16 mm	128.75 mm
Accuracy of graduation TTR ERM 2200 TTR ERM 2203	$\pm 12''$ $\pm 8''$	$\pm 10''$ $\pm 6.5''$	$\pm 8.5''$ $\pm 5.5''$	$\pm 7''$ $\pm 4.5''$	$\pm 6''$ $\pm 4''$
Interpolation error per signal period TTR ERM 2200 TTR ERM 2203	$\pm 9''$ $\pm 4.5''$	$\pm 8''$ $\pm 4''$	$\pm 6.5''$ $\pm 3.5''$	$\pm 5.5''$ $\pm 3''$	$\pm 4.5''$ $\pm 2.5''$
Reference mark	One or distance-coded				
Mech. permissible speed	$\leq 22000 \text{ rpm}$	$\leq 19000 \text{ rpm}/$ $\leq 18000 \text{ rpm}$	$\leq 18500 \text{ rpm}$	$\leq 14500 \text{ rpm}$	$\leq 13000 \text{ rpm}/$ $\leq 12500 \text{ rpm}$
Maximum angular acceleration ¹⁾	50000 rad/s^2	$27000 \text{ rad/s}^2/$ 48000 rad/s^2	20000 rad/s^2	9000 rad/s^2	$6000 \text{ rad/s}^2/$ 9000 rad/s^2
Moment of inertia	$0.15 \cdot 10^{-3} \text{ kgm}^2$	$0.32 \cdot 10^{-3} \text{ kgm}^2/$ $0.24 \cdot 10^{-3} \text{ kgm}^2$	$0.63 \cdot 10^{-3} \text{ kgm}^2$	$1.5 \cdot 10^{-3} \text{ kgm}^2$	$2.6 \cdot 10^{-3} \text{ kgm}^2/$ $2.1 \cdot 10^{-3} \text{ kgm}^2$
Permissible axial movement	$\leq \pm 1.25 \text{ mm}$				
Mass	$\approx 0.21 \text{ kg}$	$\approx 0.35 \text{ kg}/$ $\approx 0.22 \text{ kg}$	$\approx 0.44 \text{ kg}$	$\approx 0.69 \text{ kg}$	$\approx 0.89 \text{ kg}/$ $\approx 0.65 \text{ kg}$

* Please select when ordering

¹⁾ With fault exclusion for the loosening of the mechanical connection

	2400	2800	3392	4096	5200	7200
	105 mm/120 mm	130 mm/140 mm	160 mm	180 mm/220 mm	260 mm/295 mm	380 mm/410 mm
	150.88 mm	176.03 mm	213.24 mm	257.50 mm	326.90 mm	452.64 mm
	±5.5"/7" ±3.5"/5.5"	±5"/6" ±3.5"/5"	±4" ±2.5"	±3.5"/4.5" ±2"/3.5"	±3"/4" ±1.5"/3"	±2.5"/3.5" -/-
	±4" ±2"	±4" ±2"	±3" ±1.5"	±2.5" ±1.5"	±2" ±1"	±1.5" -/-
	≤ 10500 rpm	≤ 9000 rpm/ ≤ 8500 rpm	≤ 7000 rpm	≤ 6000 rpm	≤ 4500 rpm	≤ 3000 rpm
	4900 rad/s ² / 7000 rad/s ²	3300 rad/s ² / 4400 rad/s ²	1900 rad/s ²	820 rad/s ² / 1800 rad/s ²	560 rad/s ² / 1300 rad/s ²	570 rad/s ² / 960 rad/s ²
	4.4 · 10 ⁻³ kgm ² / 3.4 · 10 ⁻³ kgm ²	7.4 · 10 ⁻³ kgm ² / 6.3 · 10 ⁻³ kgm ²	16 · 10 ⁻³ kgm ²	37 · 10 ⁻³ kgm ² / 23 · 10 ⁻³ kgm ²	76 · 10 ⁻³ kgm ² / 42 · 10 ⁻³ kgm ²	240 · 10 ⁻³ kgm ² / 150 · 10 ⁻³ kgm ²
	≈ 1.0 kg/ ≈ 0.72 kg	≈ 1.2 kg/ ≈ 0.99 kg	≈ 1.8 kg	≈ 3.0 kg/ ≈ 1.6 kg	≈ 3.5 kg/ ≈ 1.7 kg	≈ 5.4 kg/ ≈ 3.2 kg

Scale drum	TTR ERM 2400 Grating period $\approx 400 \mu\text{m}$					
Measuring standard Coefficient of expansion	Steel drum $\alpha_{\text{therm}} \approx 10 \cdot 10^{-6} \text{K}^{-1}$					
Signal periods	512	600	720	900	1024	1200
Drum inside diameter*	40 mm	40 mm/55 mm	55 mm	70 mm	80 mm/95 mm	105 mm/120 mm
Drum outside diameter*	64.37 mm	75.44 mm	90.53 mm	113.16 mm	128.75 mm	150.88 mm
Accuracy of graduation	$\pm 13''$	$\pm 11''$	$\pm 10''$	$\pm 8''$	$\pm 7''$	$\pm 6''/8''$
Interpolation error per signal period	$\pm 18''$	$\pm 15.5''$	$\pm 13''$	$\pm 10.5''$	$\pm 9''$	$\pm 8''$
Reference mark	One or distance-coded					
Mech. permissible speed	$\leq 22000 \text{ rpm}$	$\leq 19000 \text{ rpm}/$ $\leq 18000 \text{ rpm}$	$\leq 18500 \text{ rpm}$	$\leq 14500 \text{ rpm}$	$\leq 13000 \text{ rpm}/$ $\leq 12500 \text{ rpm}$	$\leq 10500 \text{ rpm}$
Maximum angular acceleration ¹⁾	50000 rad/s^2	$27000 \text{ rad/s}^2/$ 48000 rad/s^2	20000 rad/s^2	9000 rad/s^2	$6000 \text{ rad/s}^2/$ 9000 rad/s^2	$4900 \text{ rad/s}^2/$ 7000 rad/s^2
Moment of inertia	$0.15 \cdot 10^{-3} \text{ kgm}^2$	$0.32 \cdot 10^{-3} \text{ kgm}^2/$ $0.24 \cdot 10^{-3} \text{ kgm}^2$	$0.63 \cdot 10^{-3} \text{ kgm}^2$	$1.5 \cdot 10^{-3} \text{ kgm}^2$	$2.6 \cdot 10^{-3} \text{ kgm}^2/$ $2.1 \cdot 10^{-3} \text{ kgm}^2$	$4.4 \cdot 10^{-3} \text{ kgm}^2/$ $3.4 \cdot 10^{-3} \text{ kgm}^2$
Permissible axial movement	$\leq \pm 1.25 \text{ mm}$					
Mass	$\approx 0.21 \text{ kg}$	$\approx 0.35 \text{ kg}/$ $\approx 0.22 \text{ kg}$	$\approx 0.44 \text{ kg}$	$\approx 0.69 \text{ kg}$	$\approx 0.89 \text{ kg}/$ $\approx 0.65 \text{ kg}$	$\approx 1.0 \text{ kg}/0.72 \text{ kg}$

* Please select when ordering

¹⁾ With fault exclusion for the loosening of the mechanical connection

	1400	1696	2048	2600	3600	3850	4800
	130 mm/140 mm	160 mm	180 mm/220 mm	260 mm/295 mm	380 mm/410 mm	450 mm	512 mm
	176.03 mm	213.24 mm	257.50 mm	326.90 mm	452.64 mm	484.07 mm	603.52 mm
	±5.5"/7"	±4.5"	±4"/5"	±3.5"/4"	±3"/3.5"	±3.5"	±3"
	±6.5"	±5.5"	±4.5"	±3.5"	±3"	±2.5"	±2"
	≤ 9000 rpm/ ≤ 8500 rpm	≤ 7000 rpm	≤ 6000 rpm	≤ 4500 rpm	≤ 3000 rpm	≤ 3000 rpm	≤ 1600 rpm
	3300 rad/s ² / 4400 rad/s ²	1900 rad/s ²	820 rad/s ² / 1800 rad/s ²	560 rad/s ² / 1300 rad/s ²	570 rad/s ² / 960 rad/s ²	470 rad/s ²	230 rad/s ²
	$7.4 \cdot 10^{-3} \text{ kgm}^2$ / $6.3 \cdot 10^{-3} \text{ kgm}^2$	$16 \cdot 10^{-3} \text{ kgm}^2$	$37 \cdot 10^{-3} \text{ kgm}^2$ / $23 \cdot 10^{-3} \text{ kgm}^2$	$76 \cdot 10^{-3} \text{ kgm}^2$ / $42 \cdot 10^{-3} \text{ kgm}^2$	$235 \cdot 10^{-3} \text{ kgm}^2$ / $151 \cdot 10^{-3} \text{ kgm}^2$	$153 \cdot 10^{-3} \text{ kgm}^2$	$713 \cdot 10^{-3} \text{ kgm}^2$
	≈ 1.2 kg/ ≈ 0.99 kg	≈ 1.8 kg	≈ 3.0 kg/ ≈ 1.6 kg	≈ 3.5 kg/ ≈ 1.7 kg	≈ 5.4 kg/ ≈ 3.2 kg	≈ 2.8 kg	≈ 9.1 kg

Scale drum	TTR ERM 2404 Grating period $\approx 400 \mu\text{m}$					
Measuring standard Coefficient of expansion	Steel drum $\alpha_{\text{therm}} \approx 10 \cdot 10^{-6} \text{K}^{-1}$					
Signal periods	360	400	512	600	900	1024
Drum inside diameter*	30 mm	30 mm	40 mm/55 mm	55 mm/60 mm	80 mm	100 mm
Drum outside diameter*	45.26 mm	50.29 mm	64.37 mm	75.44 mm	113.16 mm	128.75 mm
Accuracy of graduation	$\pm 24''$	$\pm 21''$	$\pm 17''$	$\pm 14''$	$\pm 10''$	$\pm 9''$
Interpolation error per signal period	$\pm 25.5''$	$\pm 23''$	$\pm 18''$	$\pm 15.5''$	$\pm 10.5''$	$\pm 9''$
Reference mark	One					
Mech. permissible speed	$\leq 60000 \text{ rpm}$	$\leq 54000 \text{ rpm}$	$\leq 42000 \text{ rpm}$ $\leq 38000 \text{ rpm}$	$\leq 36000 \text{ rpm}$ $\leq 30000 \text{ rpm}$	$\leq 22000 \text{ rpm}$	$\leq 20000 \text{ rpm}$
Moment of inertia	$0.027 \cdot 10^{-3} \text{ kgm}^2$	$0.045 \cdot 10^{-3} \text{ kgm}^2$	$0.12 \cdot 10^{-3} \text{ kgm}^2$ $0.06 \cdot 10^{-3} \text{ kgm}^2$	$0.19 \cdot 10^{-3} \text{ kgm}^2$ $0.16 \cdot 10^{-3} \text{ kgm}^2$	$1.0 \cdot 10^{-3} \text{ kgm}^2$	$1.4 \cdot 10^{-3} \text{ kgm}^2$
Permissible axial movement	$\leq \pm 0.5 \text{ mm}$					
Mass	$\approx 0.07 \text{ kg}$	$\approx 0.10 \text{ kg}$	$\approx 0.16 \text{ kg/}$ $\approx 0.07 \text{ kg}$	$\approx 0.17 \text{ kg/}$ $\approx 0.13 \text{ kg}$	$\approx 0.42 \text{ kg}$	$\approx 0.42 \text{ kg}$

Scale drum	TTR ERM 2904 Grating period $\approx 1000 \mu\text{m}$				
Measuring standard Coefficient of expansion	Steel drum $\alpha_{\text{therm}} \approx 10 \cdot 10^{-6} \text{K}^{-1}$				
Signal periods	180	192	256	300	400
Drum inside diameter*	35 mm	40 mm	55 mm	60 mm	100 mm
Drum outside diameter*	54.43 mm	58.06 mm	77.41 mm	90.72 mm	120.96 mm
Accuracy of graduation	$\pm 72''$	$\pm 68''$	$\pm 51''$	$\pm 44''$	$\pm 33''$
Interpolation error per signal period	$\pm 72''$	$\pm 68''$	$\pm 51''$	$\pm 44''$	$\pm 33''$
Reference mark	One				
Mech. permissible speed	$\leq 50000 \text{ rpm}$	$\leq 47000 \text{ rpm}$	$\leq 35000 \text{ rpm}$	$\leq 29000 \text{ rpm}$	$\leq 16000 \text{ rpm}$
Moment of inertia	$0.06 \cdot 10^{-3} \text{ kgm}^2$	$0.07 \cdot 10^{-3} \text{ kgm}^2$	$0.22 \cdot 10^{-3} \text{ kgm}^2$	$0.45 \cdot 10^{-3} \text{ kgm}^2$	$0.93 \cdot 10^{-3} \text{ kgm}^2$
Permissible axial movement	$\leq \pm 0.5 \text{ mm}$				
Mass	$\approx 0.11 \text{ kg}$	$\approx 0.11 \text{ kg}$	$\approx 0.19 \text{ kg}$	$\approx 0.30 \text{ kg}$	$\approx 0.30 \text{ kg}$

* Please select when ordering

Scale drum	TTR ERM 2405 Grating period $\approx 400 \mu\text{m}$	
Measuring standard Coefficient of expansion	Steel drum $\alpha_{\text{therm}} \approx 10 \cdot 10^{-6} \text{K}^{-1}$	
Signal periods	512	600
Drum inside diameter*	40 mm	55 mm
Drum outside diameter*	64.37 mm	75.44 mm
Accuracy of graduation	$\pm 17''$	$\pm 14''$
Interpolation error per signal period	$\pm 18''$	$\pm 15.5''$
Reference mark	One	
Mech. permissible speed	$\leq 33000 \text{ rpm}$	$\leq 27000 \text{ rpm}$
Moment of inertia	$0.11 \cdot 10^{-3} \text{ kgm}^2$	$0.16 \cdot 10^{-3} \text{ kgm}^2$
Permissible axial movement	$\leq \pm 0.5 \text{ mm}$	
Mass	$\approx 0.15 \text{ kg}$	$\approx 0.14 \text{ kg}$

* Please select when ordering

ERM 2200/2203/2400

Dimensions

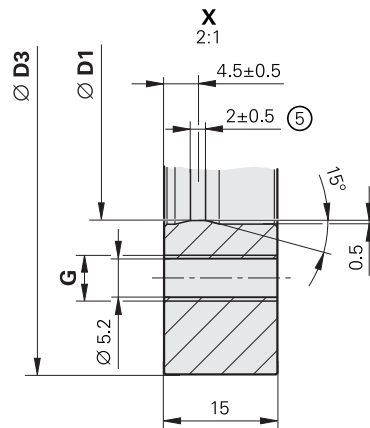
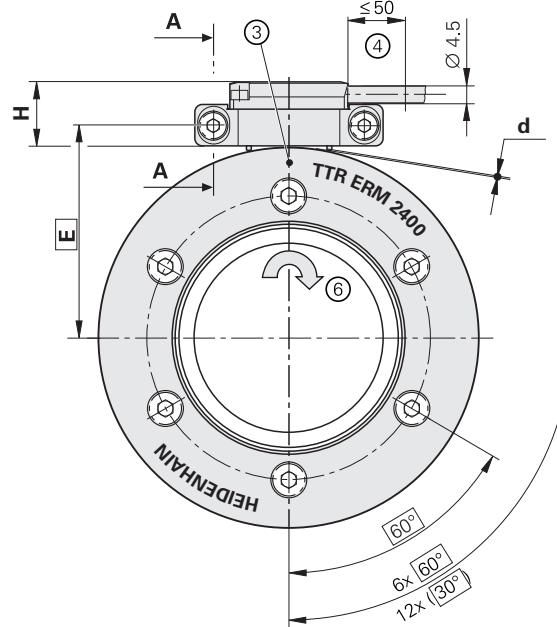
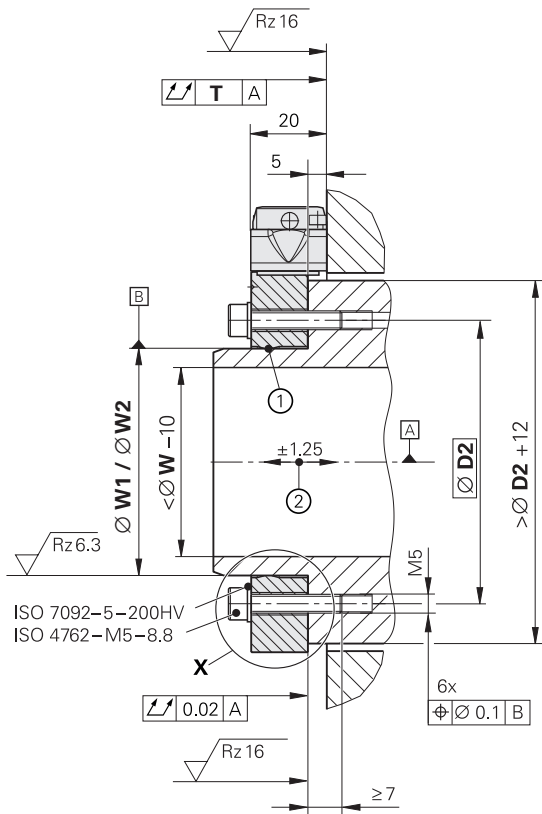

mm

 Tolerancing ISO 8015
 ISO 2768:1989-mH
 ≤ 6 mm: ±0.2 mm

W1 = Without mechanical fault exclusion
W2 = With mechanical fault exclusion
 ①, ② = Mounting possibility for scanning head

- ▣ = Bearing of mating shaft
- 1 = Shaft fit; ensure full-surface contact
- 2 = Axial tolerance of mating shaft
- 3 = Reference mark position
- 4 = Cable support
- 5 = Centering collar
- 6 = Direction of shaft rotation for ascending position values

Scanning head	H	T	Mounting clearance d (with spacer shim)	K
AK ERM 2280/2283	17 mm	0.02 mm	0.05 mm	13.6 mm
AK ERM 2293	19.5 mm	0.02 mm	0.05 mm	15.9 mm
AK ERM 2420/2480	17 mm	0.04 mm	0.15 mm	13.6 mm
AK ERM 2410	19.5 mm	0.04 mm	0.15 mm	15.9 mm

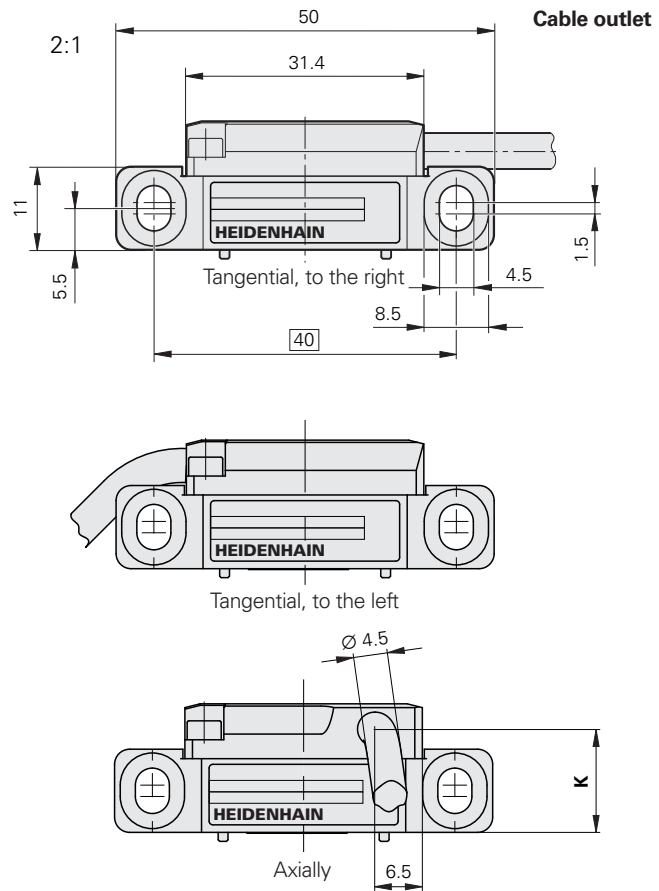
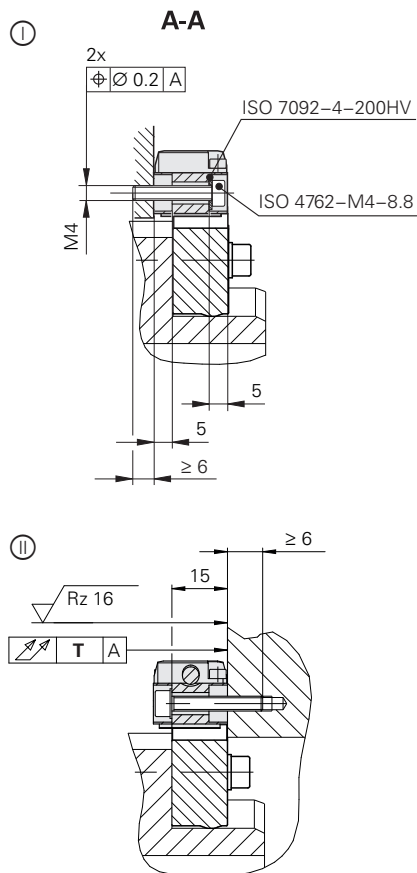

	D1	W1	W2	D2	D3	E	G
TTR ERM 2200	Ø 40 +0/-0.007	Ø 40 +0.009/+0.002	Ø 40 +0.010/+0.003	Ø 50	Ø 64.37	37.9	6x M6
TTR ERM 2203	Ø 40 +0/-0.007	Ø 40 +0.009/+0.002	Ø 40 +0.010/+0.003	Ø 50	Ø 75.44	43.4	6x M6
TTR ERM 2400	Ø 55 +0/-0.008	Ø 55 +0.010/+0.002	Ø 55 +0.015/+0.007	Ø 65	Ø 75.44	43.4	6x M6
	Ø 55 +0/-0.008	Ø 55 +0.010/+0.002	Ø 55 +0.015/+0.007	Ø 70	Ø 90.53	51.0	6x M6
	Ø 70 +0/-0.008	Ø 70 +0.010/+0.002	Ø 70 +0.019/+0.011	Ø 85	Ø 113.16	62.3	6x M6
	Ø 80 +0/-0.008	Ø 80 +0.010/+0.002	Ø 80 +0.022/+0.014	Ø 95	Ø 128.00	70.1	6x M6
	Ø 95 +0/-0.010	Ø 95 +0.013/+0.003	Ø 95 +0.029/+0.019	Ø 110	Ø 128.75	70.1	6x M6
	Ø 105 +0/-0.010	Ø 105 +0.013/+0.003	Ø 105 +0.031/+0.021	Ø 120	Ø 150.88	81.2	6x M6
	Ø 120 +0/-0.010	Ø 120 +0.013/+0.003	Ø 120 +0.036/+0.026	Ø 135	Ø 150.88	81.2	6x M6
	Ø 130 +0/-0.012	Ø 120 +0.015/+0.003	Ø 130 +0.041/+0.029	Ø 145	Ø 176.03	93.7	6x M6
	Ø 140 +0/-0.012	Ø 140 +0.015/+0.003	Ø 140 +0.044/+0.032	Ø 155	Ø 176.03	93.7	6x M6
	Ø 160 +0/-0.012	Ø 160 +0.015/+0.003	Ø 160 +0.049/+0.037	Ø 175	Ø 213.24	112.3	6x M6
	Ø 180 +0/-0.012	Ø 180 +0.015/+0.003	Ø 180 +0.055/+0.043	Ø 195	Ø 257.50	134.5	6x M6
	Ø 220 +0/-0.014	Ø 220 +0.018/+0.004	Ø 220 +0.069/+0.055	Ø 235	Ø 257.50	134.5	6x M6
	Ø 260 +0/-0.016	Ø 260 +0.020/+0.004	Ø 260 +0.082/+0.066	Ø 275	Ø 326.90	169.2	6x M6
	Ø 295 +0/-0.016	Ø 295 +0.020/+0.004	Ø 295 +0.093/+0.077	Ø 310	Ø 326.90	169.2	6x M6
	Ø 380 +0/-0.018	Ø 380 +0.022/+0.005	Ø 380 +0.119/+0.101	Ø 395	Ø 452.64	232.0	12x M6
	Ø 410 +0/-0.020	Ø 410 +0.025/+0.005	Ø 410 +0.130/+0.110	Ø 425	Ø 452.64	232.0	12x M6
	Ø 450 +0/-0.020	Ø 450 +0.025/+0.005	Ø 450 +0.142/+0.122	Ø 465	Ø 484.07	247.7	12x M6
	Ø 512 +0/-0.022	Ø 512 +0.027/+0.005	Ø 512 +0.161/+0.139	Ø 528	Ø 603.52	307.5	12x M6



Further information:

For CAD data, visit cad.heidenhain.com

ERM 2404/2405/2904

Dimensions

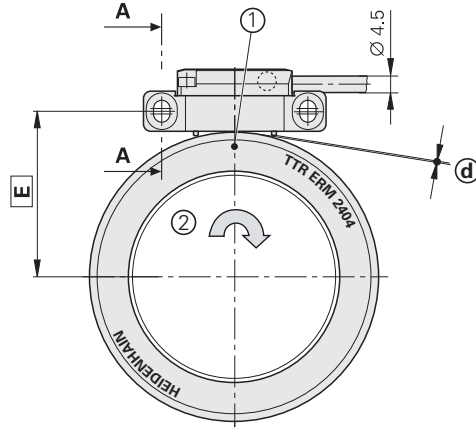
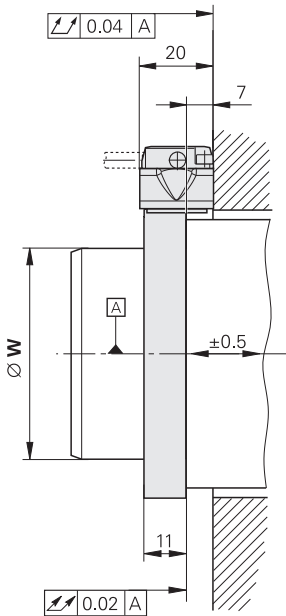

TTR ERM 2404
TTR ERM 2904

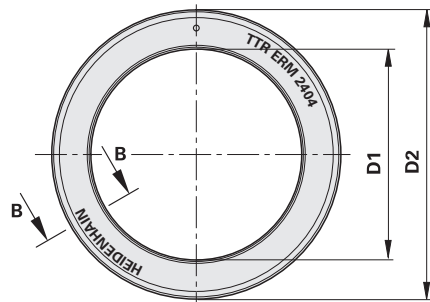

TTR ERM 2405

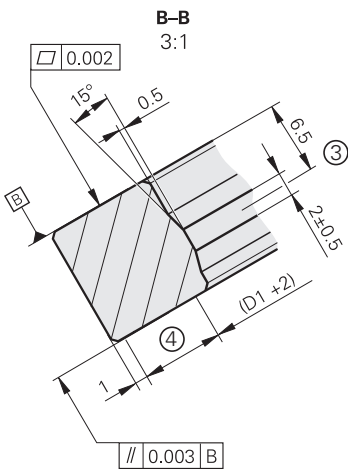
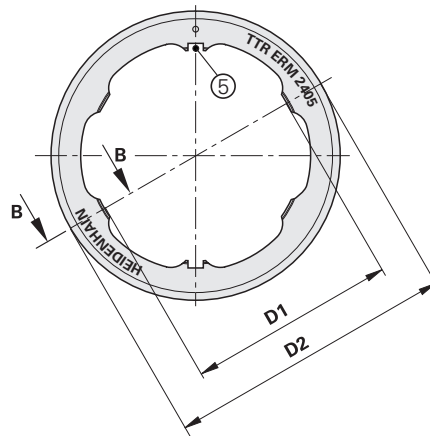

mm
 Tolerancing ISO 8015
 ISO 2768:1989-mH
 ≤ 6 mm: ±0.2 mm

- ①, ② = Mounting possibility for scanning head
- ⊠ = Bearing
- 1 = Marking for reference mark, position tolerance relative to reference mark ±5°
- 2 = Direction of shaft rotation for ascending position values
- 3 = Centering collar
- 4 = Clamping area (valid for both sides)
- 5 = Slot for machine key 4 x 4 x 10 (as per DIN 6885 Form A)

Scanning head	Mounting clearance d (with spacer shim)
AK ERM 2480	0.15 mm
AK ERM 2980	0.30 mm

**AK ERM 2480
B-B**

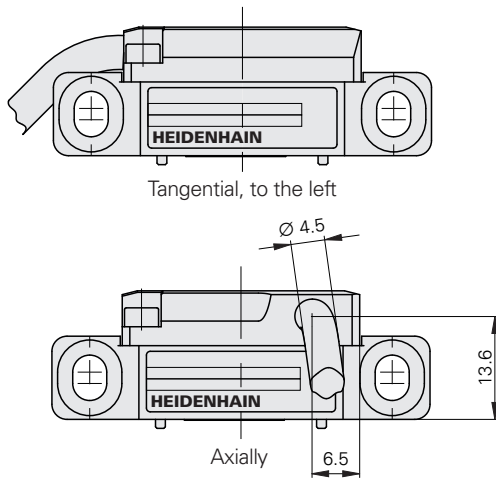
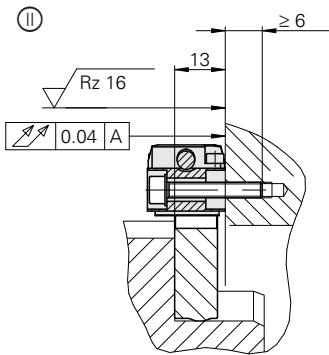
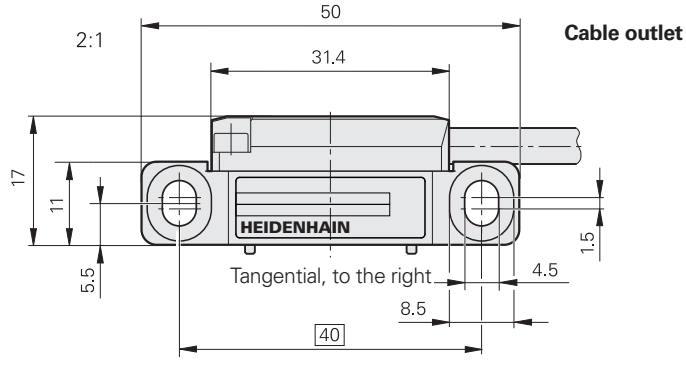
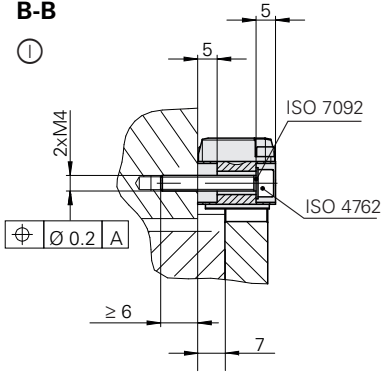

	D1	W1	D2	E
TTR ERM 2404 TTR ERM 2405	∅ 30 +0.010/+0.002	∅ 30 +0/-0.006	∅ 45.26	28.3
	∅ 30 +0.010/+0.002	∅ 30 +0/-0.006	∅ 50.29	30.9
	∅ 40 +0.010/+0.002	∅ 40 +0/-0.006	∅ 64.37	37.9
	∅ 55 +0.010/+0.002	∅ 55 +0/-0.006	∅ 64.37	37.9
	∅ 55 +0.010/+0.002	∅ 55 +0/-0.006	∅ 75.44	43.4
	∅ 60 +0.010/+0.002	∅ 60 +0/-0.006	∅ 75.44	43.4
	∅ 80 +0.010/+0.002	∅ 80 +0/-0.006	∅ 113.16	62.3
	∅ 100 +0.010/+0.002	∅ 100 +0/-0.006	∅ 128.75	70.0
TTR ERM 2904	∅ 35 +0.010/+0.002	∅ 35 +0/-0.006	∅ 54.43	32.9
	∅ 40 +0.010/+0.002	∅ 40 +0/-0.006	∅ 58.06	34.7
	∅ 55 +0.010/+0.002	∅ 55 +0/-0.006	∅ 77.41	44.4
	∅ 60 +0.010/+0.002	∅ 60 +0/-0.006	∅ 90.72	51.1
	∅ 100 +0.010/+0.002	∅ 100 +0/-0.006	∅ 120.96	66.2

 **Further information:**
For CAD data, visit cad.heidenhain.com

ERA 7000 series

Incremental angle encoder for high accuracy

- Steel scale tape for internal mounting
- Full-circle and segment versions, also for very large diameters
- Consisting of a scanning head and scale tape



ERA 7480



ERA 7481

Scanning head	AK ERA 7480
Interface	$\sim 1 V_{pp}$
Cutoff frequency -3 dB	≥ 350 kHz
Electrical connection	Cable 1 m with M23 coupling (12-pin)
Cable length	≤ 150 m (with HEIDENHAIN cable)
Supply voltage	DC 5V ± 0.5 V
Current consumption	< 100 mA (without load)
Vibration 55 to 2000 Hz Shock 6 ms	≤ 200 m/s ² (EN 60068-2-6) ≤ 1000 m/s ² (EN 60068-2-27)
Operating temperature	-10 °C to 80 °C
Mass	≈ 20 g (without cable)

Scale tape	MSB ERA 7400C full circle version MSB ERA 7401C segment version			
Measuring standard Grating period Coefficient of expansion	Steel scale-tape with METALLUR graduation 40 μ m $\alpha_{therm} \approx 10.5 \cdot 10^{-6} K^{-1}$			
Signal periods ¹⁾	36 000	45 000	90 000	
Accuracy of graduation ²⁾	$\pm 3.9''$	$\pm 3.2''$	$\pm 1.6''$	
Interpolation error per signal period ²⁾	$\pm 0.4''$	$\pm 0.3''$	$\pm 0.1''$	
Accuracy of the scale tape	± 3 μ m/m of tape length			
Reference marks	Distance-coded			
Mating diameter *	Full circle	458.62 mm	573.20 mm	1146.10 mm
	Segment	≥ 400 mm		
Mech. permissible speed	≤ 250 rpm	≤ 250 rpm	≤ 220 rpm	
Permissible axial movement	≤ 0.5 mm (scale relative to the scanning head)			
Permissible expansion coefficient of shaft	$\alpha_{therm} \approx 9 \cdot 10^{-6} K^{-1}$ to $12 \cdot 10^{-6} K^{-1}$			
Protection rating EN 60529	Complete encoder after mounting: IP00			
Mass	≈ 30 g/m			

* Please select when ordering; wider diameters of up to 3 m are available upon request

¹⁾ Validity for full-circle version; for segment solution depending on the mating diameter and the tape length

²⁾ The accuracy of the graduation and the interpolation error within one signal period together yield the encoder-specific error; for additional errors arising from mounting and the bearing of the measured shaft, see *Measurement accuracy*

ERA 7000

Dimensions

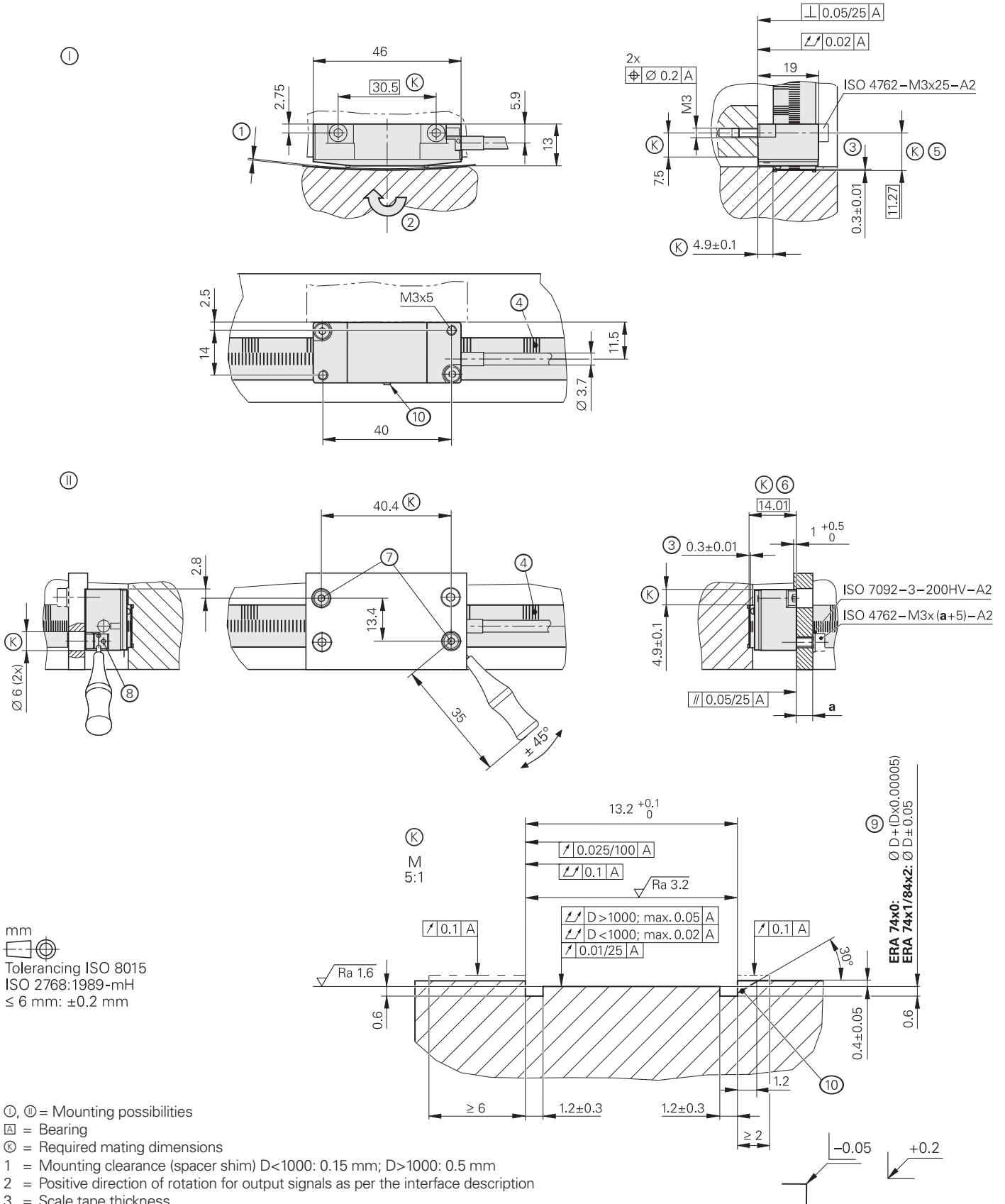

mm
 Tolerancing ISO 8015
 ISO 2768:1989-mH
 ≤ 6 mm: ±0.2 mm

- ①, ② = Mounting possibilities
- ⊠ = Bearing
- ⊙ = Required mating dimensions
- 1 = Mounting clearance (spacer shim) D<1000: 0.15 mm; D>1000: 0.5 mm
- 2 = Positive direction of rotation for output signals as per the interface description
- 3 = Scale tape thickness
- 4 = Reference mark
- 5 = Distance between the scale-tape slot floor and the fastening thread
- 6 = Distance between the scale-tape slot floor and the scanning head's rear mounting surface
- 7 = Holes required for fine adjustment
- 8 = Eccentric bushing (moiré setting)
- 9 = Scale-tape slot floor Ø D
- 10 = Notch for scale-tape disassembly (b = 2 mm)

ERA 74x1 scale tape (segment)

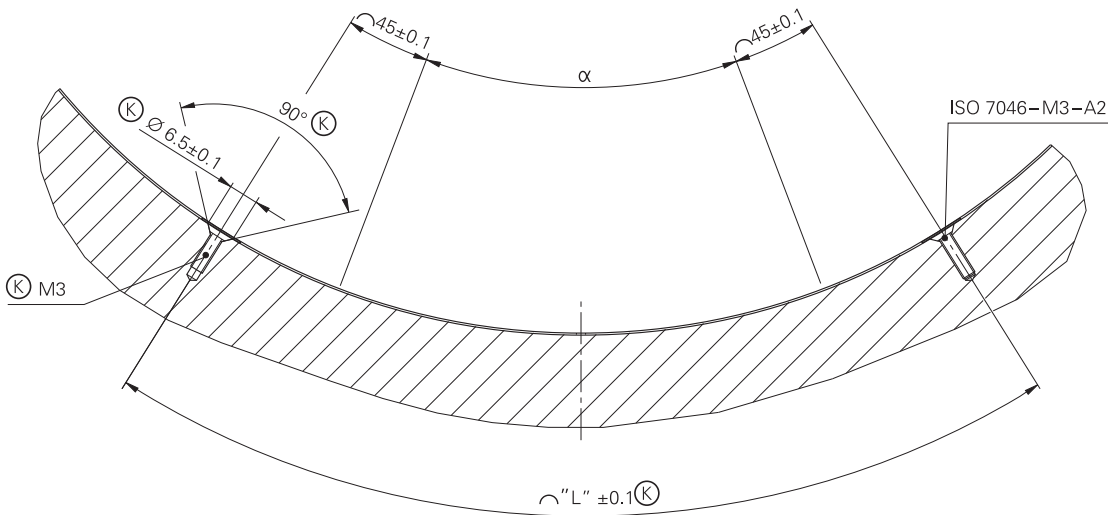
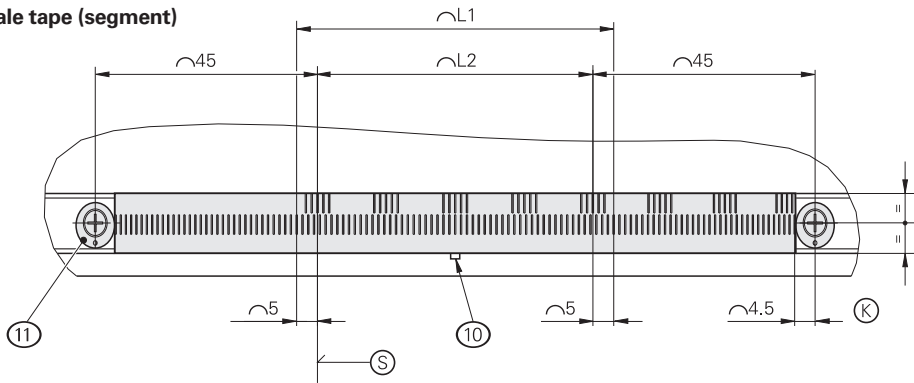

$$D = \frac{n \times 0.04 \times 0.9999}{\pi} + 0.3$$

$$\alpha = \frac{n \times 0.04 \times 0.9999}{(D - 0.3) \times \pi} \times 360^\circ$$

$$L2 = n \times 0.04 \times 0.9999$$

- ⊗ = Required mating dimensions
- ⊙ = Beginning of measurement
- 10 = Notch for scale-tape disassembly (b = 2 mm)
- 11 = Cam disk for tensioning the scale tape
- ∩ = Length of the circular arc in the stress-free zone; pay attention to thickness of scale tape
- ∩L = Position of the fastening thread
- ∩L1 = Range of traverse
- ∩L2 = Measuring range in the arc
- n = Signal period
- D = Slot-floor diameter
- α = Measuring range in degrees (segment angle)
- π = 3.14159...

ERA 8000 series

High-accuracy incremental angle encoder

- Steel scale tape for external mounting
- Full-circle and segment versions, including for very large diameters
- Optimized scanning performance for very high reliability
- Integrated three-color LED signal quality indicator
- Consisting of a scanning head and scale tape



ERA 8480 full-circle version



ERA 8481 segment version,
scale tape fastened via clamping elements

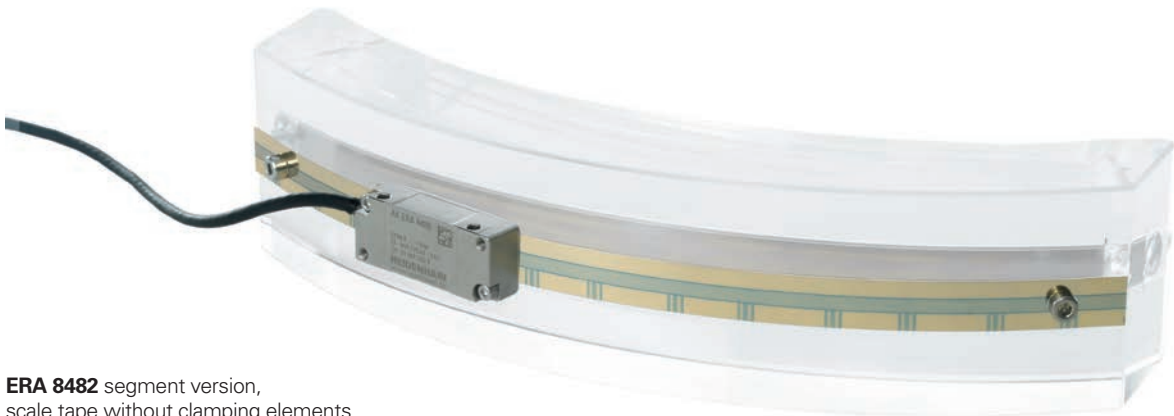

ERA 8482 segment version,
scale tape without clamping elements

Scanning head	AK ERA 8480
Interface	~ 1 V _{pp} , HSP
Cutoff frequency –3 dB	≥ 1 MHz
Electrical connection	Cable (1 m or 3 m); 12-pin M12 coupling or 12-pin M23 coupling
Cable length	≤ 150 m (with HEIDENHAIN cable)
Supply voltage	DC 5 V ±0.5 V
Current consumption	< 130 mA (without load)
Vibration 55 to 2000 Hz Shock 6 ms	≤ 200 m/s ² (EN 60068-2-6) ≤ 1000 m/s ² (EN 60068-2-27)
Operating temperature	–10 °C to 70 °C
Mass	Scanning head ≈ 20 g (without cable) Cable ≈ 20 g/m Coupling (M12) ≈ 15 g Coupling (M23) ≈ 50 g

Scale tape	MSB ERA 8400C full-circle version MSB ERA 8401C segment version with tensioning elements MSB ERA 8402C segment version without tensioning elements			
Measuring standard Grating period Coefficient of expansion	Steel scale-tape with METALLUR graduation 40 μm $\alpha_{\text{therm}} \approx 10.5 \cdot 10^{-6} \text{ K}^{-1}$			
Signal periods ¹⁾	36000	45000	90000	
Accuracy of graduation ²⁾	±4.7"	±3.9"	±1.9"	
Interpolation error per signal period ²⁾	±0.4"	±0.3"	±0.1"	
Accuracy of the scale tape	±3 μm/m of tape length			
Reference marks	Distance-coded			
Mating diameter *	Full circle	458.11 mm	572.72 mm	1145.73 mm
	Segment	≥ 400 mm		
Mech. permissible speed	≤ 50 rpm	≤ 50 rpm	≤ 45 rpm	
Permissible axial movement	≤ 0.5 mm (scale relative to the scanning head)			
Permissible expansion coefficient of shaft	$\alpha_{\text{therm}} \approx 9 \cdot 10^{-6} \text{ K}^{-1}$ to $12 \cdot 10^{-6} \text{ K}^{-1}$			
Protection rating EN 60529	Complete encoder after mounting: IP00			
Mass	≈ 30 g/m			

* Please select when ordering, additional diameters of up to 3 m are available upon request

¹⁾ Validity for full-circle version; for segment solution depending on the mating diameter and the tape length

²⁾ The accuracy of the graduation and the interpolation error within one signal period together yield the encoder-specific error; for additional errors arising from mounting and the bearing of the measured shaft, see *Measurement accuracy*

ERA 8000

Dimensions

①

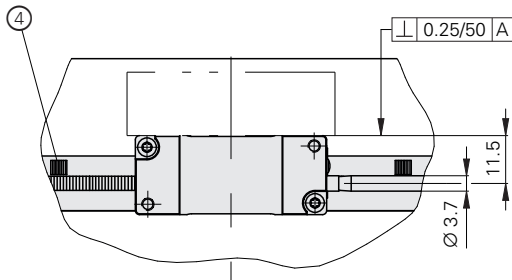
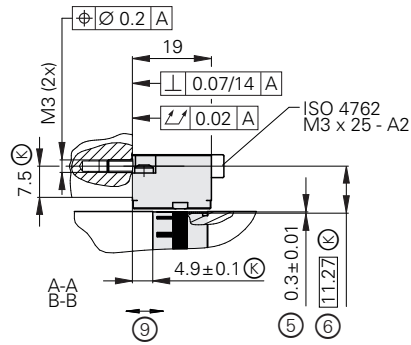
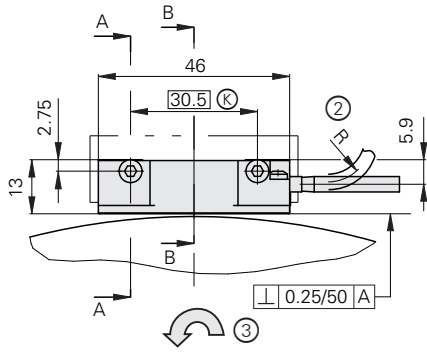

②

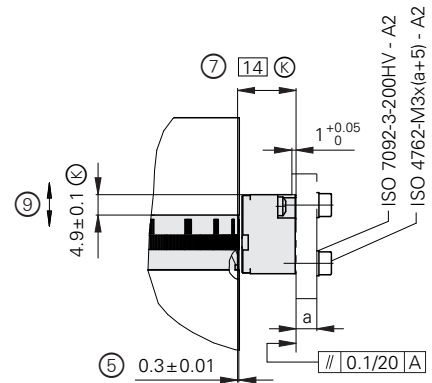
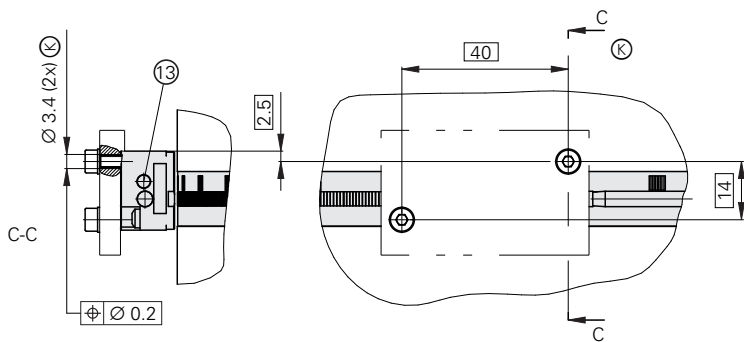

mm



Tolerancing ISO 8015
ISO 2768:1989-mH
≤ 6 mm: ±0.2 mm

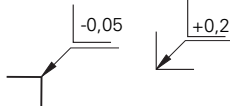

①, ② = Mounting possibilities

⊠ = Bearing

⊙ = Required mating dimensions

1 = Scale-tape slot floor $\varnothing D$

2 = Bend radius R of the cable – Fixed cable > 8 mm
– Frequent flexing > 40 mm

3 = Positive direction of rotation for output signals as per interface description

4 = Reference mark

5 = Scale-tape thickness

6 = Distance between the scale-tape slot floor and the fastening screw

7 = Distance between scale-tape slot floor and scanning head's rear mounting surface

8 = Floor of pocket is ferromagnetic for fixing the tensioning cleat

9 = Permissible axial motion (scale tape relative to the scanning head) $\leq \pm 0.5$ mm

10 = Space for mounting aid

11 = Spacer shim

12 = Mounting aid

13 = Signal-quality indicator

14 = Length of the chamfer

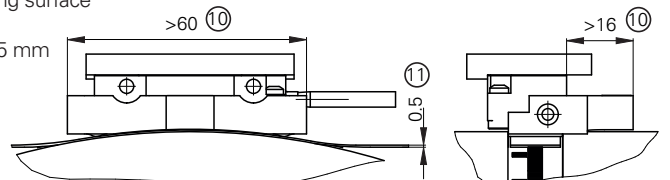
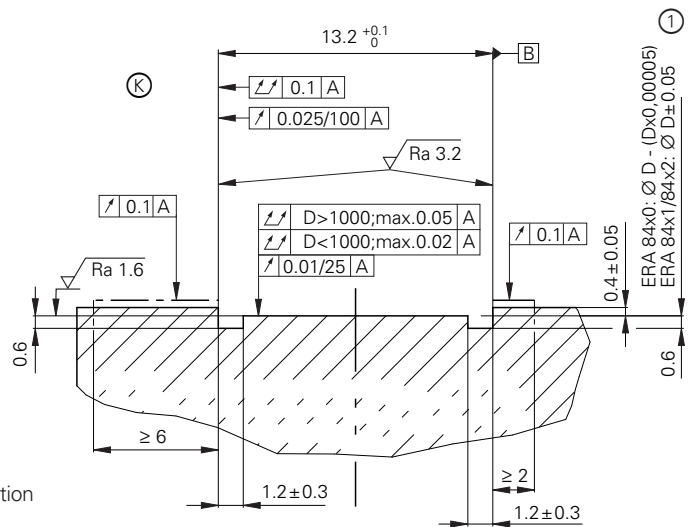

ERA 84x0 scale tape (full circle)

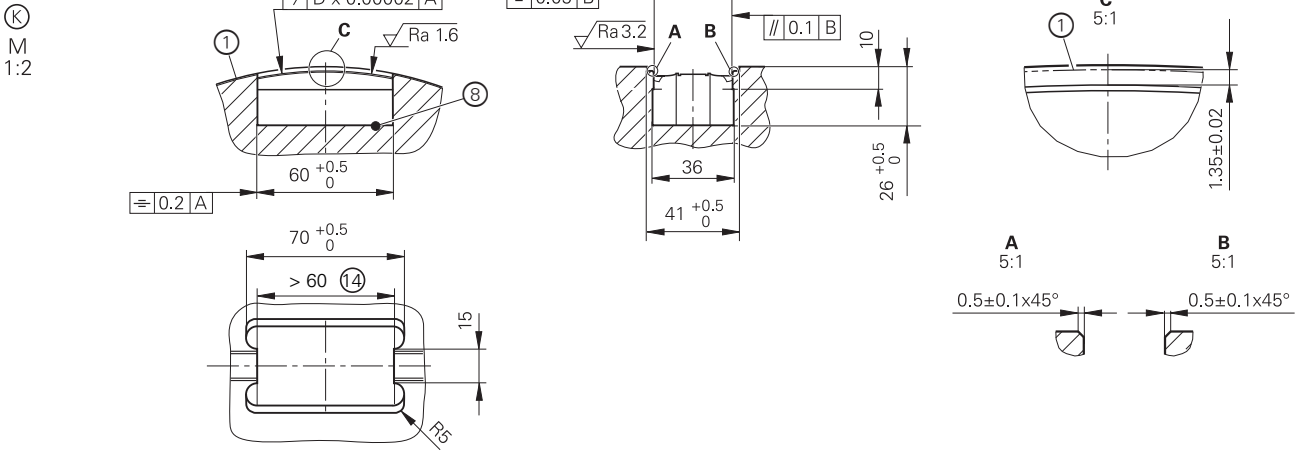

ERA 84x1 scale tape (segment)

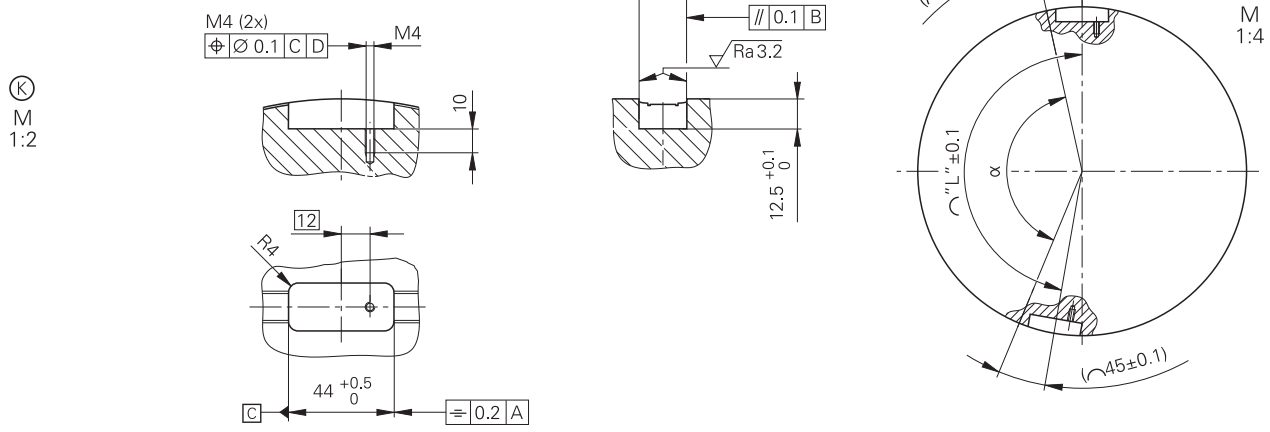

ERA 84x2 scale tape (segment)

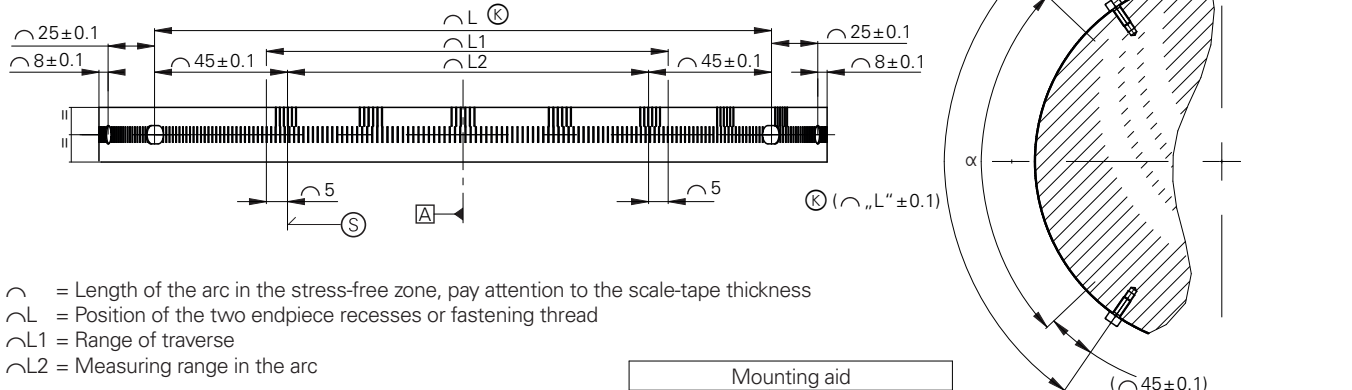

\frown = Length of the arc in the stress-free zone, pay attention to the scale-tape thickness
 $\frown L$ = Position of the two endpiece recesses or fastening thread
 $\frown L1$ = Range of traverse
 $\frown L2$ = Measuring range in the arc

n = Signal period
 D = Slot-floor diameter
 α = Measuring range in degrees (segment angle)
 π = 3.14159...

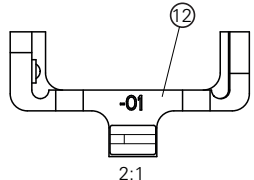

Mounting aid	
2300 - ...	1372104-08
1200 - 2300	1372104-07
800 - 1200	1372104-06
600 - 800	1372104-05
480 - 600	1372104-04
400 - 480	1372104-03
340 - 400	1372104-02
300 - 340	1372104-01
Ø	ID number

$$D = \frac{n \times 0.04 \times 1.0001}{\pi} - 0.3$$

$$\alpha = \frac{n \times 0.04 \times 1.0001}{(D + 0.3) \times \pi} \times 360^\circ$$

$$L2 = n \times 0.04 \times 1.0001$$

Testing and inspection devices, and diagnostics

HEIDENHAIN encoders provide all of the information needed for initial setup, monitoring, and diagnostics. The type of information available depends on whether the encoder is incremental or absolute and on which interface is being used.

Incremental encoders have 1 V_{PP}, TTL or HTL interfaces. TTL and HTL encoders monitor their signal amplitudes internally and generate a simple fault detection signal. With 1 V_{PP} signals, an analysis of the output signals is possible only with external testing devices or through the use of computation resources in the downstream electronics (**analog diagnostic interface**).

Absolute encoders use serial data transmission. Depending on the interface, additional 1 V_{PP} incremental signals can be output. The signals are extensively monitored within the encoder. The monitoring results (particularly valuation numbers) can be transmitted to the downstream electronics along with the position values via the serial interface (**digital diagnostic interface**). The following information is available:

- Error message: position value is not reliable
- Warning: an internal functional limit of the encoder has been reached
- Valuation numbers:
 - Detailed information about the encoder's function reserve
 - Identical scaling for all HEIDENHAIN encoders
 - Cyclic reading capability

This enables the downstream electronics to evaluate the current status of the encoder with little effort, even in closed-loop mode.

For the analysis of these encoders, HEIDENHAIN offers the appropriate PWM inspection devices and PWT testing devices. Based on how these devices are integrated, a distinction is made between two types of diagnostics:

- Encoder diagnostics: the encoder is connected directly to the testing or inspection device, thereby enabling a detailed analysis of encoder functions.
- Monitoring mode: the PWM inspection device is inserted within the closed control loop (via suitable testing adapters as needed). This enables real-time diagnosis of the machine or equipment during operation. The available functions depend on the interface.

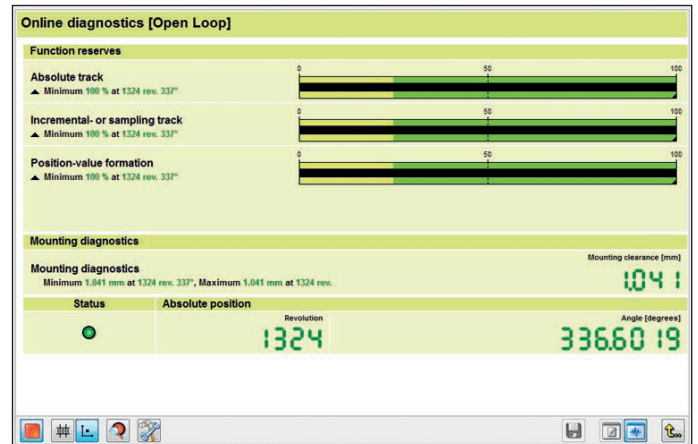

Diagnostics with the PWM 21 and ATS software

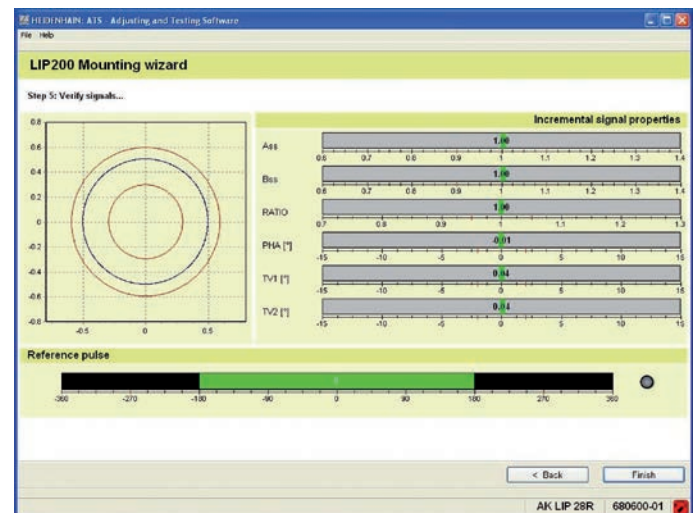

Initial setup with the PWM 21 and ATS software



Further information:

For detailed descriptions regarding diagnostics, inspection devices and testing devices, please refer to the *Interfaces of HEIDENHAIN Encoders* brochure.

HEIDENHAIN

Mastering nanometer accuracy



HEIDENHAIN

DR. JOHANNES HEIDENHAIN GmbH
Dr.-Johannes-Heidenhain-Straße 5
83301 Traunreut, Germany
☎ +49 8669 31-0
☎ +49 8669 32-5061
info@heidenhain.de
www.heidenhain.com



HEIDENHAIN
worldwide