

Mounting Instruction

MSA 650

Mounting options

- The best location for mounting a Linear Encoder is to mount it as near to the centerline of the slide, or as close to the guideways of the machine.
- To mount the Linear Encoder, two mounting surfaces are required; one for the extrusion and one for the encoder head. If the unit cannot be mounted directly onto the slide, then mounting brackets would be required.
- Mount the Linear Encoder so the encoder head never runs into the end of the extrusion, for overtraveling the measuring length will destroy the unit!
- If possible, the extrusion should be mounted on the moving part of the machine guideway and the encoder head fixed, so that the cable is rigidly attached to the machine and continuous cable flexure and the chance of a cable snag are eliminated.
- The Linear Encoder has protective sealing lips to protect against dust and water drops, providing that it is mounted in such a way that the sealing lips of the extrusion are mounted down or away from the contamination side of the machine.

If it is not possible to mount the sealing lips away from the machine contamination, then the unit must be protected using an additional cover (sheet metal cover or bellows).

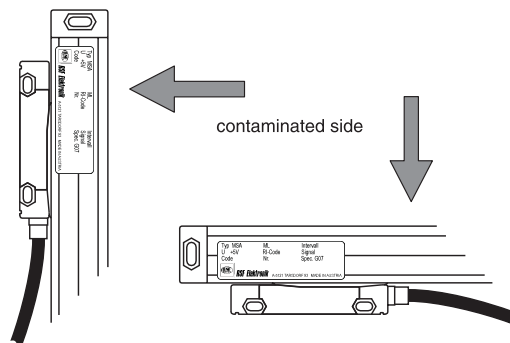

Mounting of the extrusion

- First, mount the extrusion and loosely tighten the mounting screws.
- Adjust the mounting so that the extrusion is parallel to the machine guideway, and tighten the screws with a maximum torque of 1 Nm (8 in-lb).

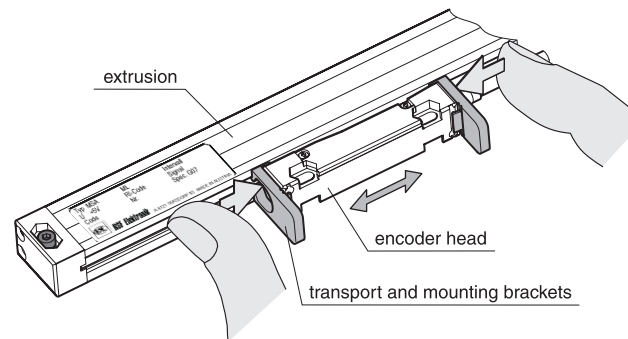

Mounting of the encoder head

- Move the encoder head carefully by hand to the mounting surface.
- Initially, lightly tighten the screws.
- Adjust the encoder head gap to the mounting gap and tolerance (1 mm gap), and tighten the mounting screws with a maximum torque of 1,5 Nm (12 in-lb).

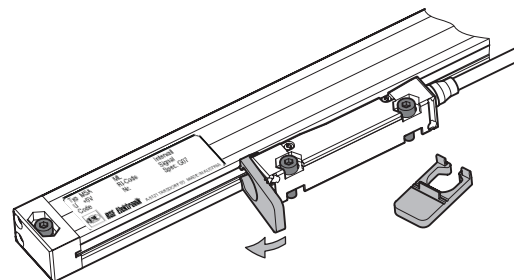

Inspection of the mounting

- Move the slide over the full range of motion to make sure that full machine travel can be obtained without the encoder contacting the end of the scale extrusion. Otherwise, the Linear Encoder will be damaged!

Tying down the cables

- On machines with cutting fluids and splash water, where the cable is sloped downward, the fluids will run down the cable. Even though the encoder head is sealed where the cable enters the encoder head, it is better to have a downward bend of the cable, just prior to encoder head entry, so that the fluids have no chance of running into the encoder head.
- **With sensor lines, the maximum overall cable length is 30 m!**

Attention!

- **The measuring length of the Linear Encoder must be longer than the travel length of the machine!**
- **Remove transport brackets prior to operation**
- **Never tilt the encoder head with respect to the extrusion**
- **Do not connect or disconnect the encoder head cable connector with the Digital Readout or Control power on**
- **With sensor lines the maximum overall cable length is 30 m!**

For technical data please look at our catalogue
"Incremental Linear Encoders"

Dimensions - Mounting tolerances - Mounting possibilities:

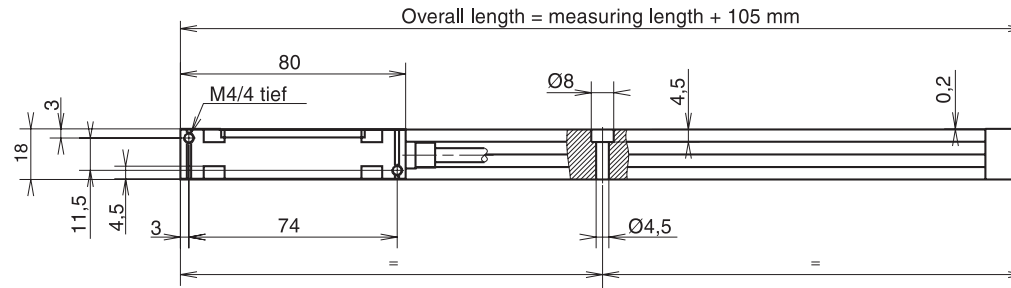

For measuring length over 520 mm scale should be affixed with epoxy resin adhesive (e. g. UHU - Plus) cementing gap max. 0,2 mm

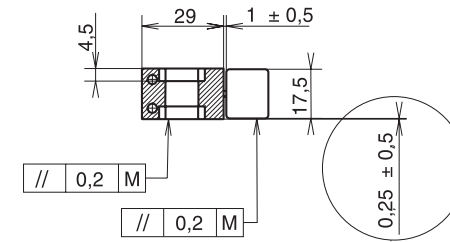

M = Machine guideway

