

Order separately:
 Separat bestellen:
 A commander séparément:
 Ordinare a parte:
 Para pedir por separado:

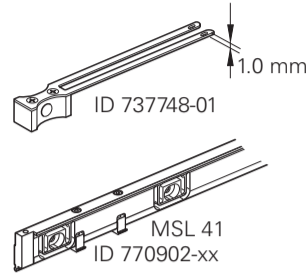

HEIDENHAIN

Mounting Instructions
 Montageanleitung
 Instructions de montage
 Istruzioni di montaggio
 Instrucciones de montaje

LC 4x6

Absolute linear encoder
 Absolutes Längenmessgerät
 Système de mesure linéaire absolu
 Sistema di misura assoluto
 Sistema lineal de medida absoluto



05/2022

1356261 · Ver00 · 01

General Information · Allgemeine Hinweise · Informations générales · Informazioni generali · Información general



Note: Mounting and commissioning is to be conducted by a qualified specialist under compliance with local safety regulations. Do not engage or disengage any connections while under power. The drive must not be put into operation during installation.

Achtung: Die Montage und Inbetriebnahme ist von einer qualifizierten Fachkraft unter Beachtung der örtlichen Sicherheitsvorschriften vorzunehmen.

Die Steckverbindung darf nur spannungsfrei verbunden oder gelöst werden. Der Antrieb darf während der Montage nicht in Betrieb gesetzt werden.

Attention: Le montage et la mise en service doivent être assurés par un personnel qualifié dans le respect des consignes de sécurité locales.

La connexion ou la déconnexion ne doit être établie qu'hors tension. L'entraînement ne doit pas être mis en route pendant le montage.

Attenzione: Il montaggio e la messa in funzione devono essere eseguite da personale qualificato nel rispetto delle norme di sicurezza locali.

Collegare o staccare i collegamenti soltanto in assenza di tensione. L'azionamento non deve essere messo in funzione durante il montaggio.

Atención: El montaje y la puesta en marcha deben ser realizados por un especialista cualificado, observando las prescripciones locales de seguridad.

El conector sólo puede enchufarse o soltarse sin tensión.

El accionamiento no debe estar en marcha durante el montaje.

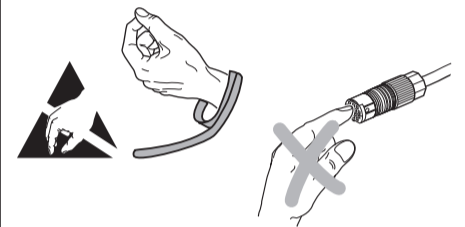

Dimensions in mm
 Maße in mm
 Cotes en mm
 Dimensioni in mm
 Dimensiones en mm

General Information · Allgemeine Hinweise · Informations générales · Informazioni generali · Información general

Mounting surface clean and free of paint
 Anbaufläche sauber und lackfrei
 Surface de montage propre et exempte de peinture
 Superficie di montaggio pulita e non verniciata
 Superficie de montaje limpia y libre de barniz

ML = Measuring length
 Messlänge
 Longueur de mesure
 Corsa utile
 Longitud de medición

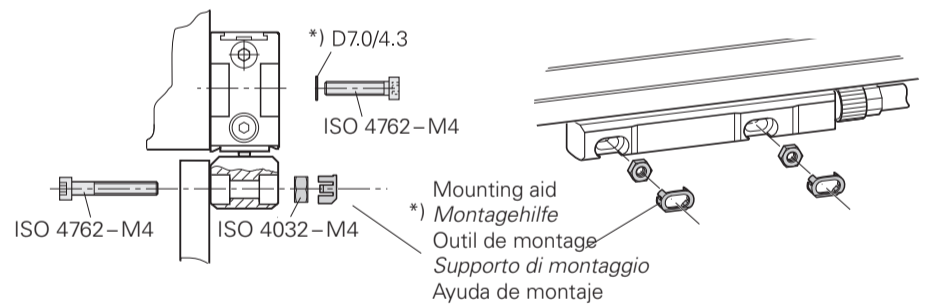
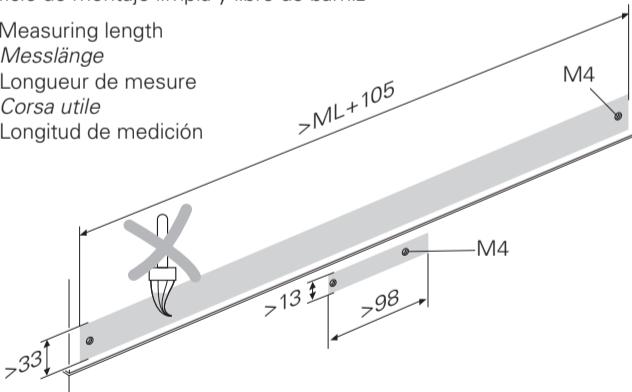

*) Included in delivery
 Im Lieferumfang enthalten
 Contenu dans la fourniture
 Standard di fornitura
 Elementos suministrados

General Information · Allgemeine Hinweise · Informations générales · Informazioni generali · Información general

Unlock the shipping brace to move the scanning head
 Zum Verschieben der Abtasteinheit, Transportsicherung entriegeln
 Pour faire glisser la tête caprice, déverrouiller la sécurité de transport
 Per spostare la testina, sbloccare il supporto per il montaggio
 Para desplazar el cabezal, desbloquear el seguro de transporte

Move scanning unit back and forth
 Abtasteinheit verschieben
 Faire glisser la tête caprice
 Spostare la testina
 Desplazar el cabezal captador

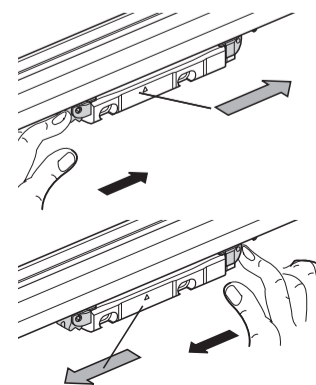
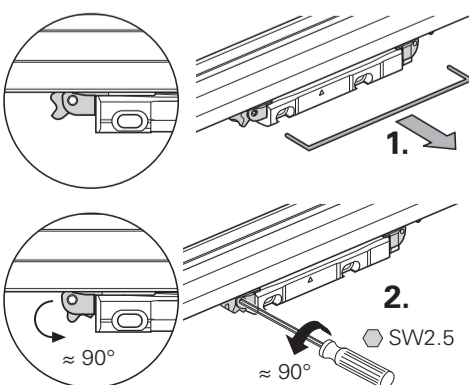

Assembly · Montage · Montage · Montaggio · Montaje

Ⓢ = Begin. of meas. length ML
 Beginn der Messlänge ML
 Début longueur utile ML
 Inizio lunghezza di misura ML
 Comienzo longitud útil ML

F = Machine guideway
 Maschinenführung
 Guidage de la machine
 Guida della macchina
 Guía de la máquina

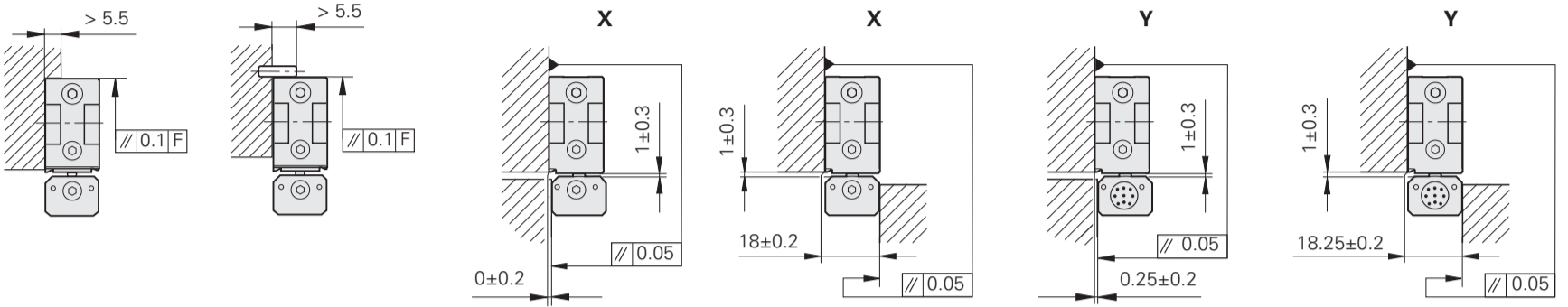
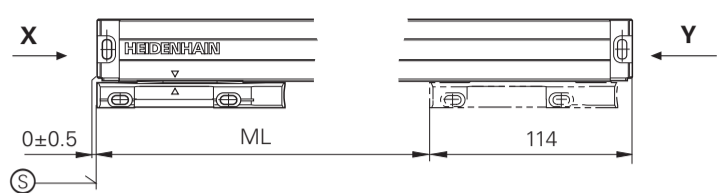
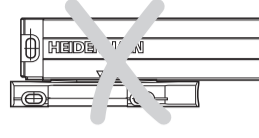

1. ML > 620

Center fastening required
 Mittige Befestigung notwendig
 Fixation centrale nécessaire
 Necessario fissaggio al centro
 Fijación central necesaria

P = Points for alignment
 Punkte zum Ausrichten
 Points pour alignement
 Punti per l'allineamento
 Puntos para la alineación

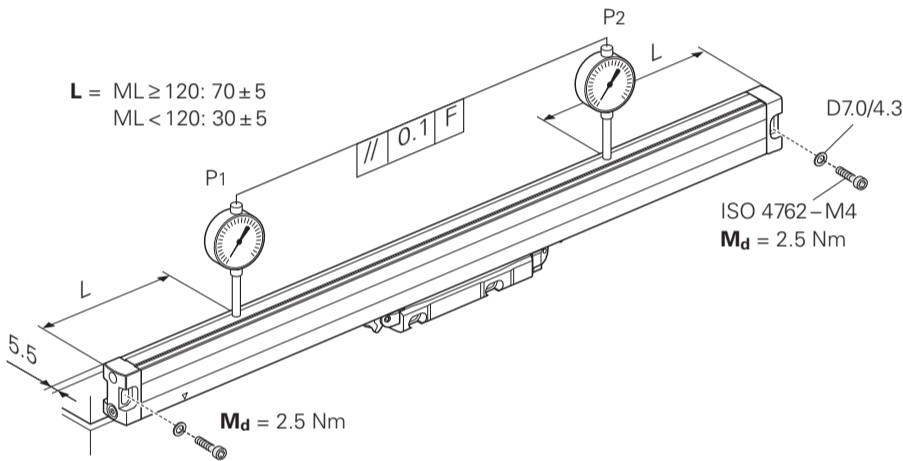

2.

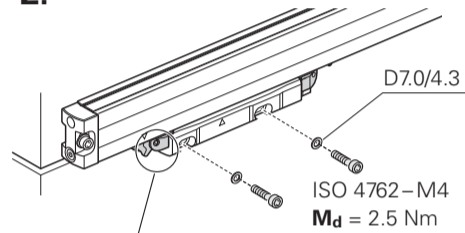

Items supplied
 Lieferumfang
 Contenu de la fourniture
 Standard di fornitura
 Elementos suministrados

The locked shipping brace sets the following dimensions:
 Verriegelte Transportsicherung stellt folgende Maße ein:
 La sécurité de transport verrouillée règle les cotes suivantes:
 Il supporto per il montaggio sbloccato presenta le seguenti dimensioni:
 El seguro de transporte bloqueado ajusta las siguientes cotas:

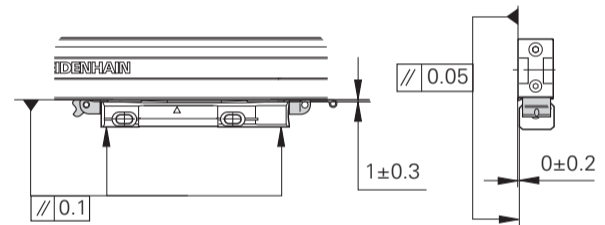

3. Remove the shipping brace

Transportsicherung entfernen
 Retirer la sécurité de transport
 Rimuovere il dispositivo di sicurezza per il trasporto
 Retirar el seguro de transporte

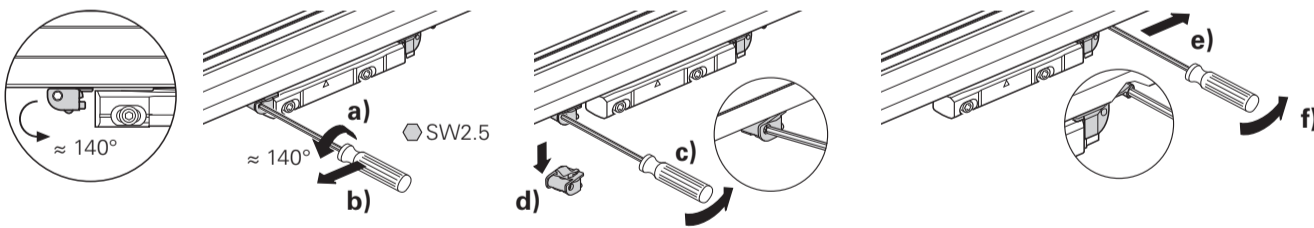

Final Steps · Abschließende Arbeiten · Opérations finales · Operazioni finali · Trabajos finales

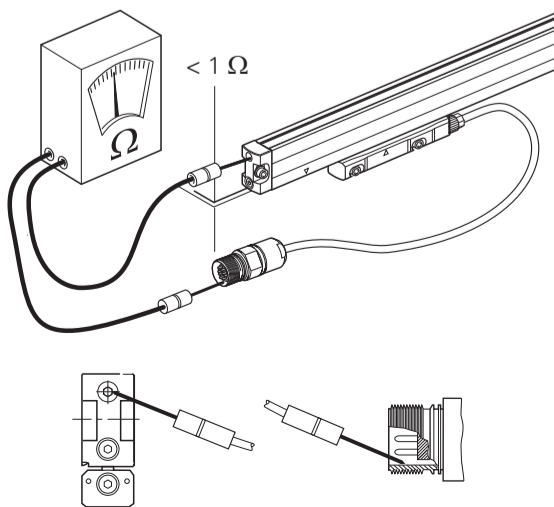

optional · optional · option · opzionali · opcional

Ⓢ = Compressed-air connection usable at either end
 Druckluftanschluss beidseitig möglich
 Raccordement d'air comprimé possible des deux côtés
 Connessioni per aria compressa sui due lati
 Toma de aire comprimido posible por ambos lados

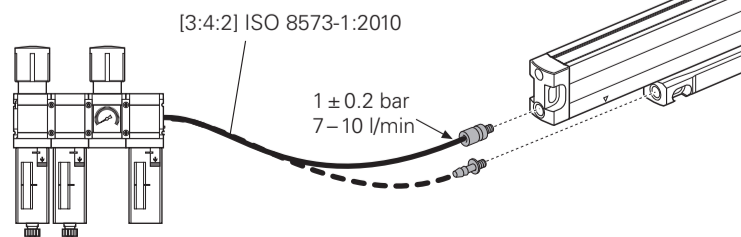
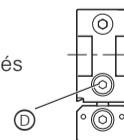

Vertical mounting
 Senkrechter Anbau
 Montage verticale
 Montaggio verticale
 Montaje vertical

