



# RSF Elektronik

[www.rsf.at](http://www.rsf.at)

## MSA 7x0, MSA 8x0 SEALED LINEAR ENCODERS







## INCREMENTAL AND ABSOLUTE LINEAR AND ANGLE ENCODERS, PRECISION GRADUATIONS

RSF Elektronik is one of the world's leading companies in the field of electronic linear and angle encoders and it offers an extensive portfolio which includes almost all designs which are required by the market. The typical resolutions or measuring steps range from a few micrometers down to the nanometre range.



RSF Elektronik, corporate head quarters Tarsdorf, Austria



RSF Elektronik, manufacturing subsidiary Stříbro, Czech Republic

Another core element of the product range are high-precision and resistant graduations which are manufactured in thin-layer technology on glass or other carrier substrates. RSF Elektronik also develops customized cable devices for the widest range of sectors and areas of application, and these are manufactured by the Stříbro subsidiary. In order to safeguard the company's high quality standard, a comprehensive quality assurance and environmental management system – certified according to DIN EN ISO 9001 and DIN EN ISO 14001 – has been put in place. Thanks to the company's extensive distribution network, optimum customer service is guaranteed in practically all regions.

## TABLE OF CONTENTS

<b>GENERAL DESCRIPTION</b>	Design and operation .....	04
<b>TECHNICAL INFORMATION</b>	Accuracy .....	06
	Connection cables, shielding, connectors, pin assignments .....	07
	Interfaces .....	08
	Switch signal output .....	09
<b>OVERVIEW</b>	Overview, selection guide .....	10
	Technical data .....	11
<b>LINEAR ENCODERS, MODELS</b>	MSA 770, MSA 870 .....	12
	MSA 710, MSA 810 .....	13
	MSA 720, MSA 820 .....	14
	MSA 730, MSA 830 .....	15
<b>DISTRIBUTION CONTACTS</b>	Addresses .....	16

## DESIGN AND OPERATION

Linear encoders from RSF Elektronik are all-purpose. They are suited for manual applications; yet they are also particularly suitable for closed loop drive devices.

Owing to their sealed design, the linear encoders of the **MSA 7** and **MSA 8** series are predestined for applications in **automation** and **production technology**. They are ideally suited for **metrology**, **printing** and **robotics**, especially in applications where protection for the scale and reading head is required.

**MSA 7** and **MSA 8** represent a systematic advancement of tried-and-tested devices and feature improved design details. During development, RSF Elektronik paid particular attention to the optimization of the accuracy of these devices. We achieved this goal thanks to the perfect combination of several individual components. Furthermore, the components that are subject to more stress have been optimized to increase system accuracy over the longer term.

Measuring devices are made up of two components: the **extrusion** and **reading head**. Preferably, the extrusion is to be mounted on the moveable part of the linear axis, and the reading head to the fixed part (cable duct) of the linear axis.

The **extrusion** consists of a stable aluminum scale housing, fastening elements, a scale and sealing lips.

Drip caps at the scale housing and specially formed sealing lips prevent the intrusion of dust and liquids into the extrusion. The fiber-reinforced sealing lips are highly abrasion-resistant. High velocities are feasible due to the high degree of rigidity of the unit, coupled with the ideally formed blade area of the reading head.

The **scale** is fastened by dint of a flexible adhesive film in the scale housing, which compensates for the differing linear expansion between the glass or glass ceramics and the aluminum. Thus a **reproducible thermal behavior** is ensured (expansion or shortening of the scale to the scale housing in case of temperature changes). The scale can additionally be fixed in the scale housing in order to adjust the thermal zero point to each measuring requirement. Expansion differences between aluminum scale housing and machine slide are evened out by flexible fastening elements. The **high accuracy of the measuring scale** is the result of a sophisticated lithographic process. A consistently accurate reproduction of the original measuring scale forms the basis for the manufacture of the highly accurate scales in RSF Elektronik measuring devices.

Depending on the model, the **reading head** is available with a **fixed** or **detachable cable**. The **reading carriage** includes a reticle and optoelectronics for signal generation. Hall-sensors are integrated in the reading head, which generate

switch signals for an additional position detection or enable a selection of reference marks. They are activated by magnets that can be optionally positioned in any way on the extrusion by the customer. The evaluation electronics are positioned in the **reading carriage**, generating the evaluation signals (e.g. 1 Vpp or TTL).

Thanks to the design of the reading carriage alignment deviations between extrusion and machine guide are evened out. It rolls by dint of high-precision roller bearings on the scale and is pressed down by magnets that affect the ferromagnetic tapes on the extrusion (**magnet guide**). By mounting within the tolerance there are no forces between reading head and extrusion that could stress guide parts of the linear axis. Moreover, the extrusion is not subjected to any bending strain.

In the measuring direction, the reading carriage is connected by a wear-free and maintenance-free **magnetic coupling**. A ferromagnetic ball rolling freely between two magnetic plates makes for a connection that is very stiff in the measuring direction, yet flexible in all other degrees of freedom, minimizing the reversal error. Thus any deviation (within the tolerance) will be evened out by the ideal mounting of the measurement device.

*The combination of magnetic guide and magnetic coupling allows for generous mounting tolerances without any negative influence on accuracy. Hence substantial benefits are achieved in comparison to traditional technologies.*

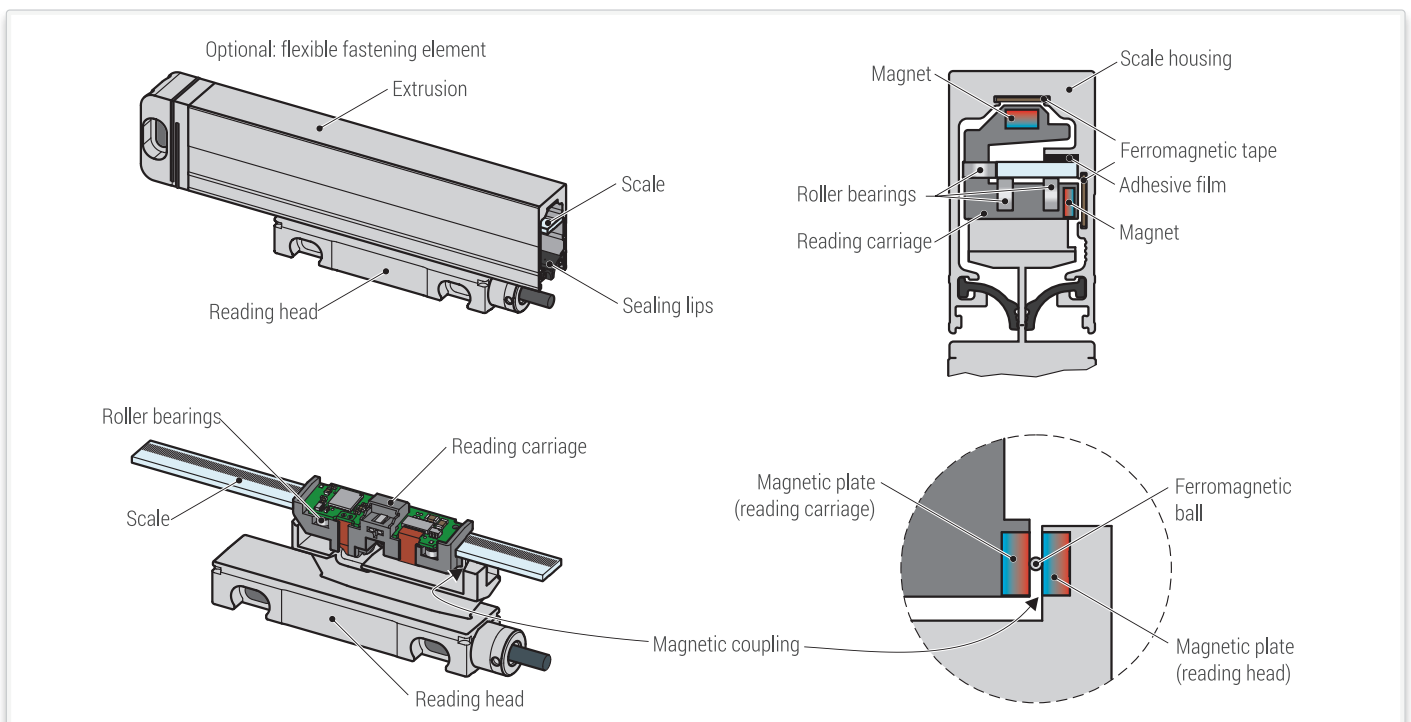



A high accuracy grating is deployed as scale graduation. Depending on the model, glass ( $\alpha \approx 8,5 \times 10^{-6}/K$ ) or glass ceramics ( $\alpha \approx 0 \times 10^{-6}/K$ ) is employed as base.

The grating is the consistent series of lines and spaces. The width of one line and one space is called a grating period (T).

Parallel to the grating, there are one or more reference marks on a second track. Within the measuring length, any position is possible and additional reference marks can be chosen at will in a distance of 50 mm.

Linear encoders can also be equipped with distance-coded reference marks. After traveling a distance of 20 mm at maximum, the absolute tool position is available with these models. By dint of the optical scanning, a position-accurate evaluation of the reference marks is ensured.

#### Scale unit

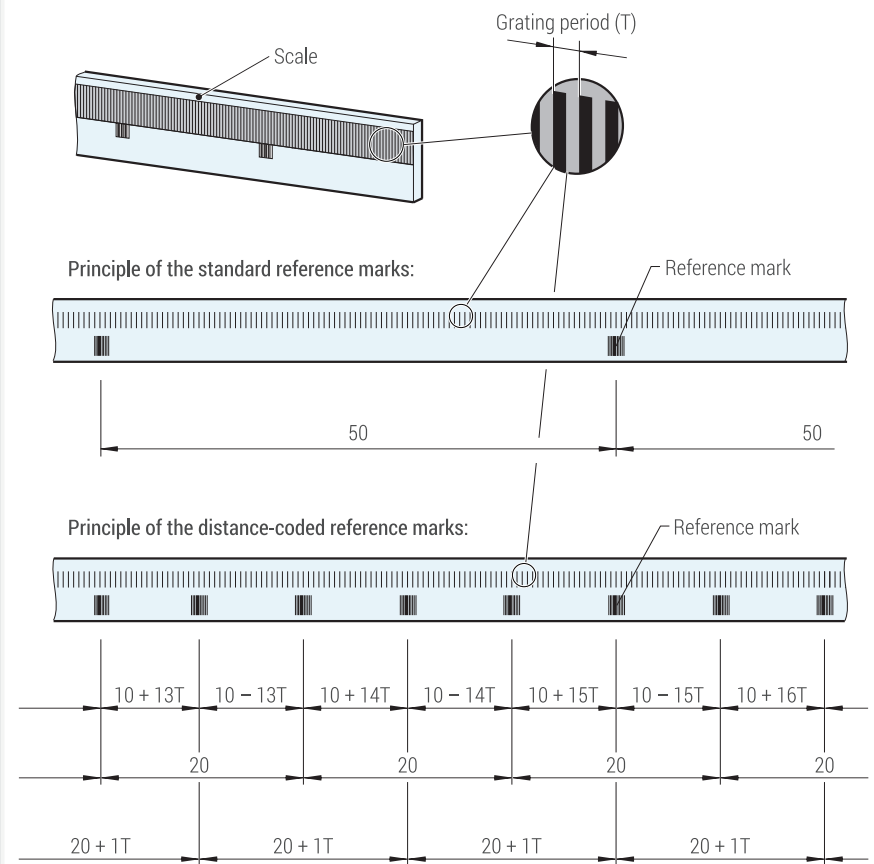

These incremental linear encoders work according to a photoelectric measuring principle with a transmissive **singlefield scanning**.

The regulated light of an infrared LED is collimated by a condenser lens, passes through the grid of the reticle and the scale and generates a periodic intensity distribution on the structured sensor.

The sensor generates sinusoidal signals of the highest quality that prove to be widely insensitive to possible contaminations, which can never be entirely ruled out despite all technical precautions.

The regulation of the LED ensures a constant signal amplitude, guaranteeing stability in the case of temperature fluctuations as well as with long-run operation.

#### Transmissive singlefield scanning

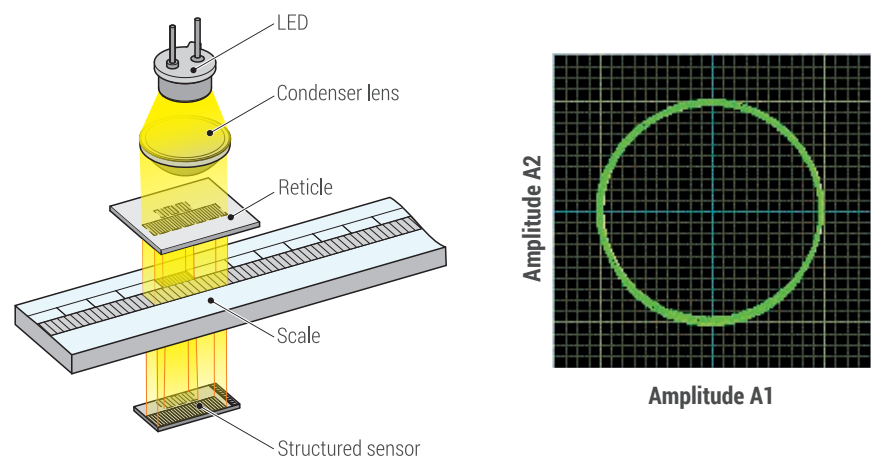

## ACCURACY

The accuracy of the linear encoders is classified with a „± tolerance“ in  $\mu\text{m}/\text{m}$  (e.g.  $\pm 5 \mu\text{m}/\text{m}$ ).

The accuracy refers to any meter within the measuring length.

For measuring lengths less than 1000 mm, the accuracy specification applies to the whole measuring length.

For best system accuracy, the encoder should be mounted near the measuring plane, as parallel as possible to the machine guideway.

Example of a typical calibration chart for MSA 770:

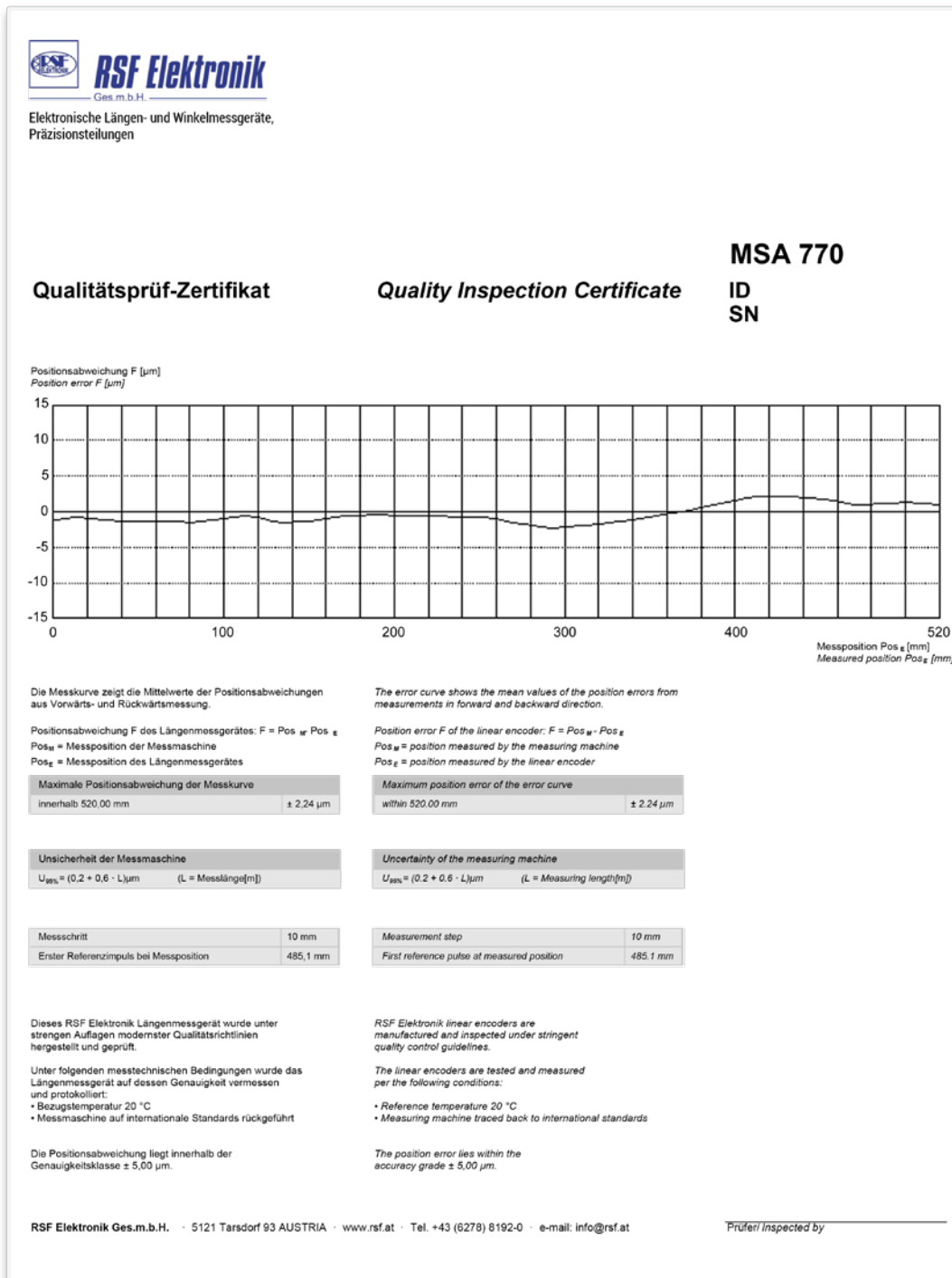

# CONNECTING CABLE, SHIELDING

## Connecting cable MSA 7

Graduated cable lengths: 0.5 m, 1 m, 3 m (other lengths on request).

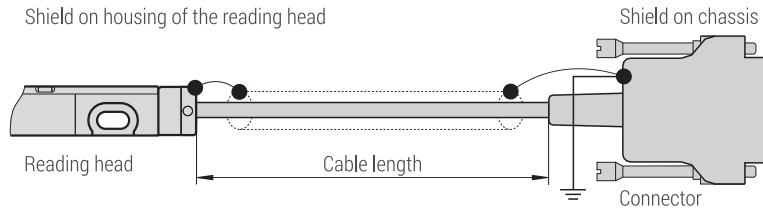

Shielded PUR-cable;  
Drag chain qualified.

Bending radius  
fixed mounting

Bending radius  
continuous flexing

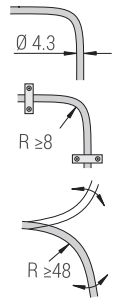

## Detachable connecting cable MSA 8

Graduated cable lengths: 0.5 m, 1 m, 3 m (other lengths on request).

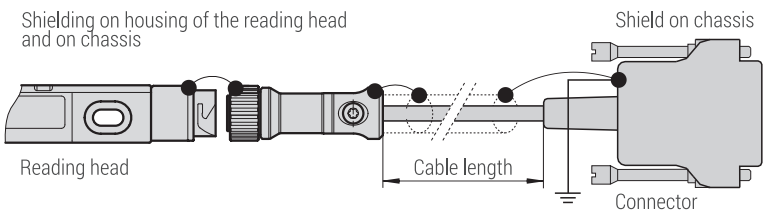

Shielded PUR-cable;  
Drag chain qualified.

Bending radius  
fixed mounting

Bending radius  
continuous flexing

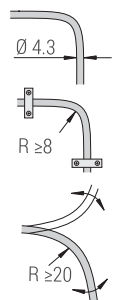

# MALE CONNECTORS, PIN ASSIGNMENTS

## D-sub connector, 15-pin

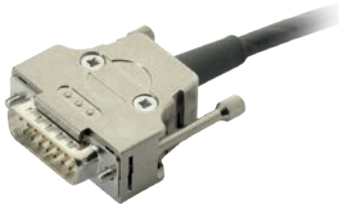

**Dimensions**  
(Male, 15-pin, mass: 25 g)

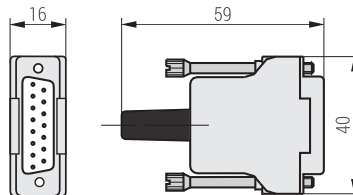

**Pin assignment**  
View on pins

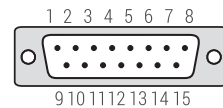

Pin	1	2	3	4	5	6	7	8	9	10	11	12	13	14	15
Sinusoidal voltage signals 1 Vpp	Occupied	0 V Sensor	Occupied	RI-	A2-	A1-	V+ Sensor	V+	0 V	S1*	S2*	RI+	A2+	A1+	nc
TTL-signals	Occupied	0 V Sensor	US	RI	T2	T1	V+ Sensor	V+	0 V	S1*	S2*	RI	T2	T1	nc

## M12 connector, 12-pin

according to IEC 61076-2-101 LM012-Gxx-A



**Dimensions**  
(Male, 12-pin, mass: ca. 15 g)

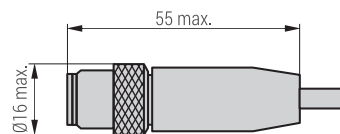

**Pin assignment**  
View on pins

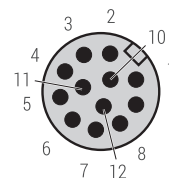

Pin	1	2	3	4	5	6	7	8	9	10	11	12
Sinusoidal voltage signals 1 Vpp	V+	A1-	A2+	A2-	S2*	Occupied	RI+	RI-	Occupied	A1+	S1*	0 V
TTL-signals	V+	T1	T2	T2	S2*	US	RI	RI	Occupied	T1	S1*	0 V

- Sensor: the sensor pins are bridged in the chassis with the particular power supply.
- \* Version without switch signals (version K) = nc.
- Shield is connected with the chassis.
- Pins or wires marked "occupied" or "nc" must not be used by the customer.

## INTERFACES

### SINUSOIDAL VOLTAGE SIGNALS 1 V<sub>PP</sub>

(drawing shows "positive counting direction")

Two sinusoidal voltage signals A1 and A2 and one reference mark signal (all with inverted signals).

**Power supply:** +5 V ±10 %, max. 150 mA (unloaded)

**Track signals** (differential voltage A1+ to A1- resp. A2+ to A2-):

Signal amplitude 0.6 V<sub>pp</sub> to 1.2 V<sub>pp</sub>; typ. 1 V<sub>pp</sub>

(with terminating impedance Z<sub>0</sub> = 120 Ω between A1+ to A1- resp. A2+ to A2-)

**Reference mark** (differential voltage RI+ to RI-):

Square-wave pulse with an amplitude of 0.5 to 0.9 V; typ. 0.7 V

(with terminating impedance Z<sub>0</sub> = 120 Ω between RI+ to RI-)

**Advantage:**

High traversing speed with long cable lengths possible.

### SQUARE-WAVE SIGNALS

(drawing shows "positive counting direction")

With integrated interpolation electronics (for times -5, -10, -25 or -50) the photoelement output signals are converted into two square-wave signals that have a phase shift of 90°. The output signals are "differential" via line driver (RS 422). The measuring step equates to the distance between two edges of the square-wave signals.

The controls/DROs must be able to detect each edge of the square-wave signals. The minimum edge separation a<sub>min</sub> is listed in the technical data and refers to a measurement at the output of the interpolator (inside the reading head). Propagation-time differences in the line driver, the cable and the line receiver reduce the edge separation.

**Propagation-time differences:**

Line driver: max. 10 ns

Cable: 0.2 ns/m

Line receiver: max. 10 ns (referred to the recommended line receiver circuit)

To prevent counting errors, the controls/DROs must be able to process the resulting edge separation.

**Example:**

a<sub>min</sub> = 125 ns, 10 m cable

125 ns - 10 ns - 10 x 0.2 ns - 10 ns = 103 ns

**Power supply:** +5 V ±10 %, max. 180 mA (unloaded)

**Advantages:**

- Noise immune signals

- No further subdividing electronics necessary

### Voltage signals (1 V<sub>PP</sub>)

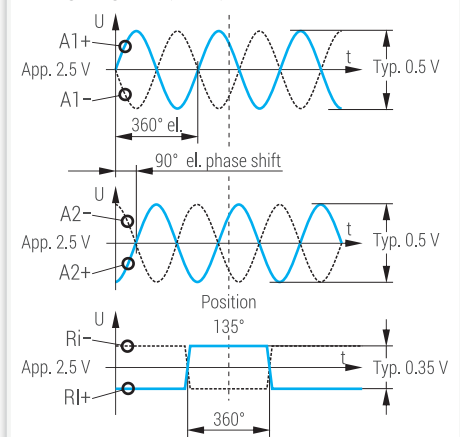

### Square-wave signals „differential“

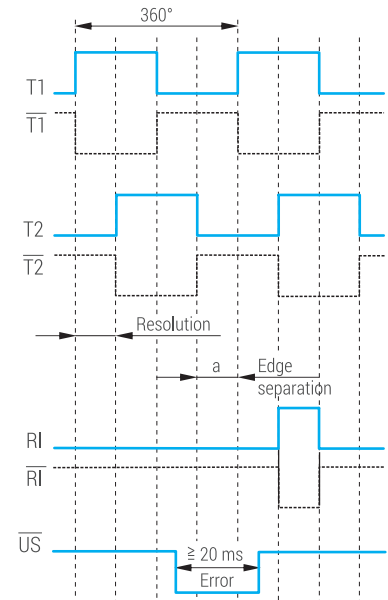

### Recommended line receiver

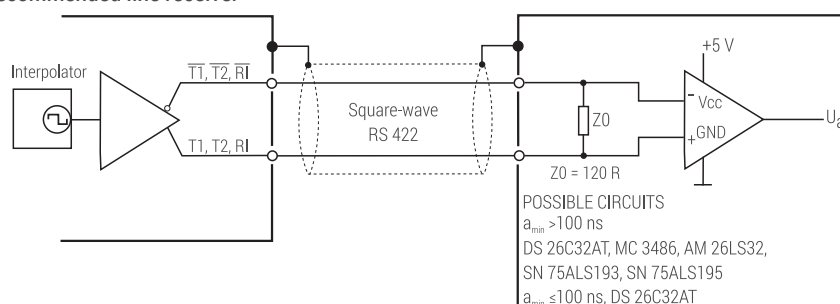

### „Positive counting direction“

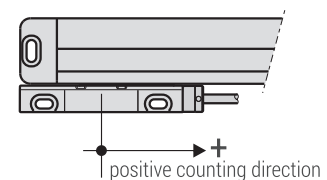



# SWITCH SIGNAL OUTPUT

## VERSION H

TTL output (active high)

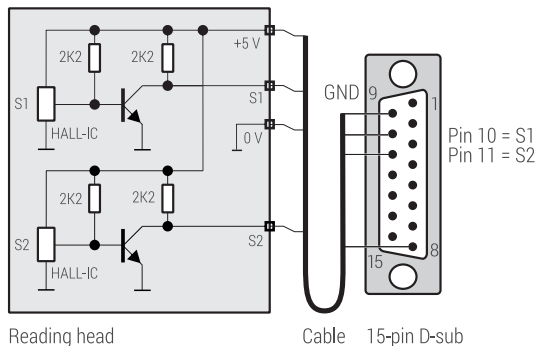

Reading head

Cable 15-pin D-sub

S1, S2 = TTL output  
 $I_{SOURCE} = 1 \text{ mA}$  (high level  $> 2 \text{ V}$ )  
 $I_{SINK} = 20 \text{ mA}$  (low level  $< 0.8 \text{ V}$ )

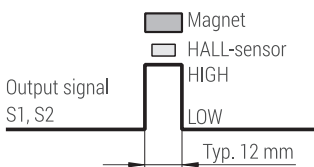

## VERSION Z

Open collector output (active high impedance)

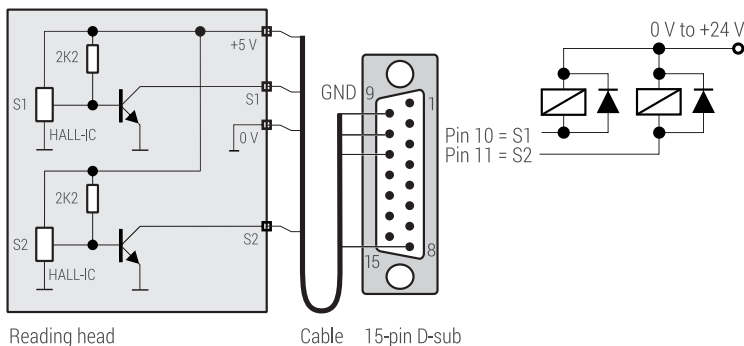

Reading head

Cable 15-pin D-sub

S1, S2 = Open collector output  
 $I_{SINK} = 20 \text{ mA}$  (low level  $< 0.8 \text{ V}$ )

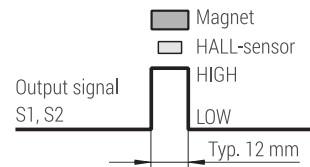

## VERSION L

TTL Ausgang (active low)

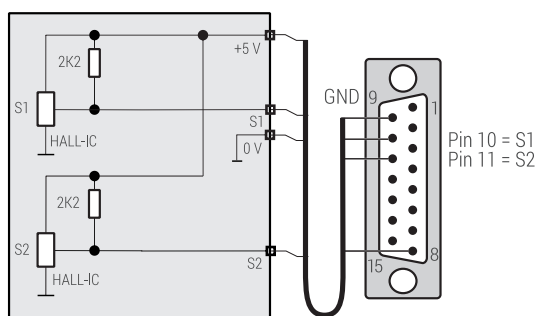

Reading head

Cable 15-pin D-sub

S1, S2 = TTL output  
 $I_{SOURCE} = 1 \text{ mA}$  (high level  $> 2 \text{ V}$ )  
 $I_{SINK} = 20 \text{ mA}$  (low level  $< 0.8 \text{ V}$ )

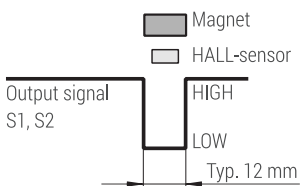

## VERSION C

Open collector output (active low)

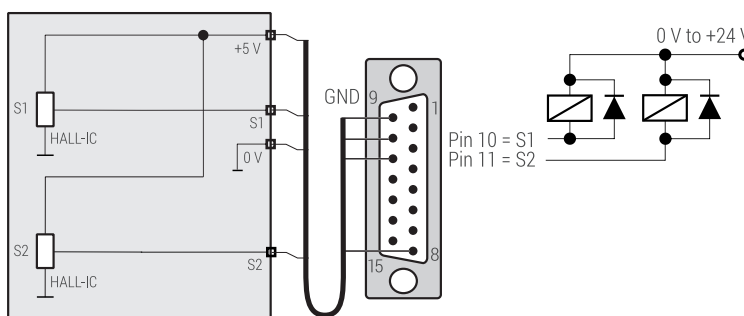

Reading head

Cable 15-pin D-sub

S1, S2 = Open collector output  
 $I_{SINK} = 20 \text{ mA}$  (low level  $< 0.8 \text{ V}$ )

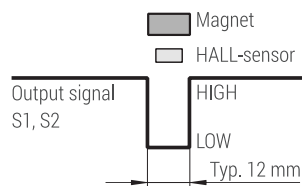

According to factory default setting the actuator magnets are placed at the beginning (S1) and at the end (S2) of measuring length. The magnets can be moved by the customer.

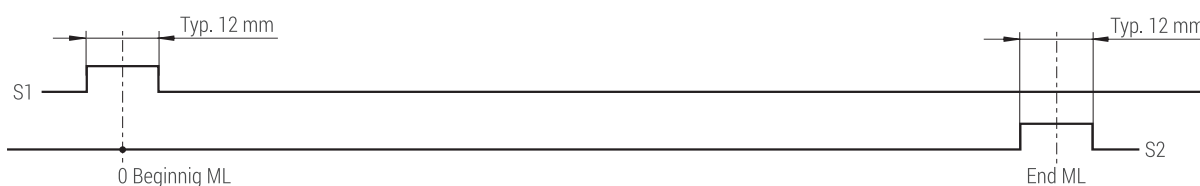

## OVERVIEW, SELECTION GUIDE

Linear encoders **MSA 7x0** are equipped with a fixed connecting cable.

Alternatively RSF offers **MSA 8x0** with a detachable connecting cable.

The models **MSA 7x0** and **MSA 8x0** are characterized by a considerably improved thermal behavior.

Flexible fastening elements at the scale unit compensate repeatably the length-extension resp. -contraction, which appears due to temperature variations at the machine.

With a fixed fastening element (left side, middle or right side) a datum-point (thermal fixed-point) is defined.

Additionally it is also possible to fix the scale inside of the extrusion.

### MSA 7x0

- Small cross-section
- Max. measuring length: 1240 mm
- Fixed connecting cable
- System height: 46 mm resp. 54 mm

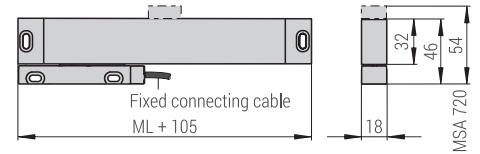

### MSA 8x0

- Small cross-section
- Max. measuring length: 1240 mm
- Detachable connecting cable
- System height: 49 mm resp. 57 mm

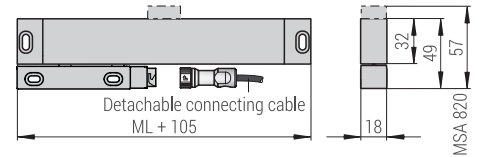

= Fixed fastening element    
 = Flexible fastening element    
 = Additional fixed-point of the scale in the extrusion

### MSA X70

- Mounting holes at the ends
- Fixed fastening elements

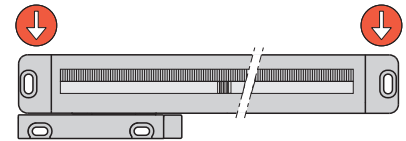

MSA 770, MSA 870 [Page 12](#)

### MSA X10

- Fixed mounting-point left
- Flexible fastening element right

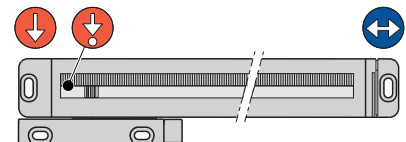

MSA 710, MSA 810 [Page 13](#)

### MSA X20

- Fixed mounting-point centered
- Flexible fastening element left and right

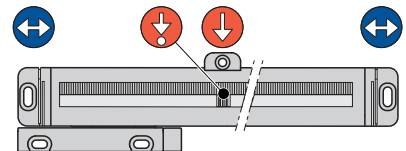

MSA 720, MSA 820 [Page 14](#)

### MSA X30

- Fixed mounting-point right
- Flexible fastening element left

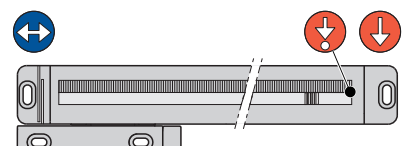

MSA 730, MSA 830 [Page 15](#)

# TECHNICAL DATA MSA 7x0, MSA 8x0

## READING HEAD

Model	MSA 7x0 MSA 8x0	MSA 7x0 MSA 8x0	MSA 7x0 MSA 8x0	MSA 7x0 MSA 8x0	MSA 7x0 MSA 8x0
Interface	~ 1 Vpp	⌋ TTLx5	⌋ TTLx10	⌋ TTLx25	⌋ TTLx50
Measuring step	Depending on external interpolation	1.0 µm	0.5 µm	0.2 µm	0.1 µm
Signal period	20 µm	--	--	--	--
Integrated interpolation	--	Times 5	Times 10	Times 25	Times 50
Max. velocity	2.0 m/s	2.0 m/s	1.96 m/s	0.78 m/s	0.78 m/s
Max. output frequency	100 kHz	--	--	--	--
Edge separation a <sub>min</sub>	--	250 ns	250 ns	250 ns	125 ns
Electrical connection	Cable, 0.5 m, 1 m or 3 m mit D-sub connector 15-pin or M12 connector 12-pin				
Voltage supply	<ul style="list-style-type: none"> <li>Sinusoidal voltage signals ~ 1 Vpp: +5 V ±10 %</li> <li>Square-wave signals via line driver ⌋: +5 V ±10 %</li> </ul>				
Power consumption max.	<ul style="list-style-type: none"> <li>Sinusoidal voltage signals ~ 1 Vpp: 825 mW (without load)</li> <li>Square-wave signals via line driver ⌋: 990 mW (without load)</li> </ul>				
Current consumption typ.	<ul style="list-style-type: none"> <li>Sinusoidal voltage signals ~ 1 Vpp: 150 mA (without load)</li> <li>Square-wave signals via line driver ⌋: 180 mA (without load)</li> </ul>				
Vibration 55 Hz – 2000 Hz Shock 8 ms	100 m/s <sup>2</sup> 200 m/s <sup>2</sup>				
Operating temperature Storage temperature	0 °C to 50 °C -20 °C to 70 °C				
Mass reading head	<ul style="list-style-type: none"> <li>MSA 7x0: 50 g (without cable)</li> <li>MSA 8x0: 65 g (without cable)</li> <li>Cable: 30 g/m, connector: D-sub connector: 28 g, M12 connector: 15 g</li> </ul>				

## GRADUATION CARRIER

Standard measuring lengths (ML): [mm]	70, 120, 170, 220, 270, 320, 370, 420, 470, 520, 570, 620, 670, 720, 770, 820, 870, 920, 970, 1040, 1140, 1240 (other measuring lengths on request)
Graduation carrier	<ul style="list-style-type: none"> <li>Glass scale (<math>\alpha \approx 8.5 \times 10^{-6}/K</math>), grating period: 20 µm</li> <li>Glass ceramic scale (<math>\alpha \approx 0 \times 10^{-6}/K</math>), grating period: 20 µm</li> </ul>
Accuracy grades (at 20 °C)	<ul style="list-style-type: none"> <li>±5 µm/m</li> <li>±3 µm/m</li> </ul>
Location of the reference marks (RI):	<ul style="list-style-type: none"> <li>Distance-coded reference marks</li> <li>One reference mark in the middle of the ML</li> <li>Up to ML 970 mm: 35 mm from left and right; from ML 1040 mm: 45 mm from left and right</li> </ul>
Required moving force	<ul style="list-style-type: none"> <li>With standard sealing lips (NBR): &lt; 2.0 N</li> </ul>
Environmental protection EN 60529	<ul style="list-style-type: none"> <li>With standard sealing lips (NBR): IP 53</li> </ul>
Mass scale spar (approx.)	<ul style="list-style-type: none"> <li>MSA 7xx, MSA 8xx: 75 g + 0.57 g/mm (ML)</li> </ul>

## CONFORMITIES AND CERTIFICATIONS

RoHS	2011/65/EU, 2015/863/EU
EMV	2014/30/EU
Product-Certifications	UL, CSA, EN, IEC 61010-1

## MSA 770, MSA 870



### Dimensions, mounting tolerances MSA 770:

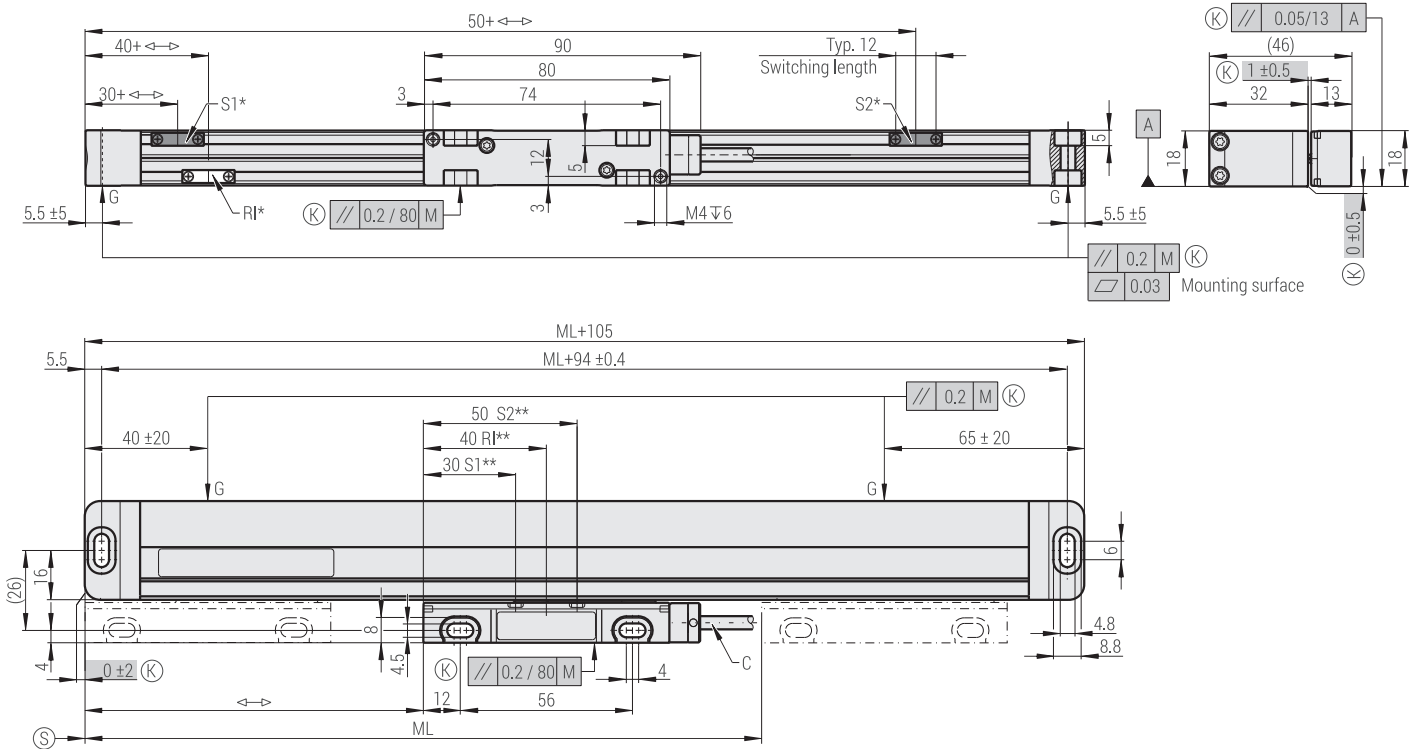

### Dimensions, mounting tolerances MSA 870:

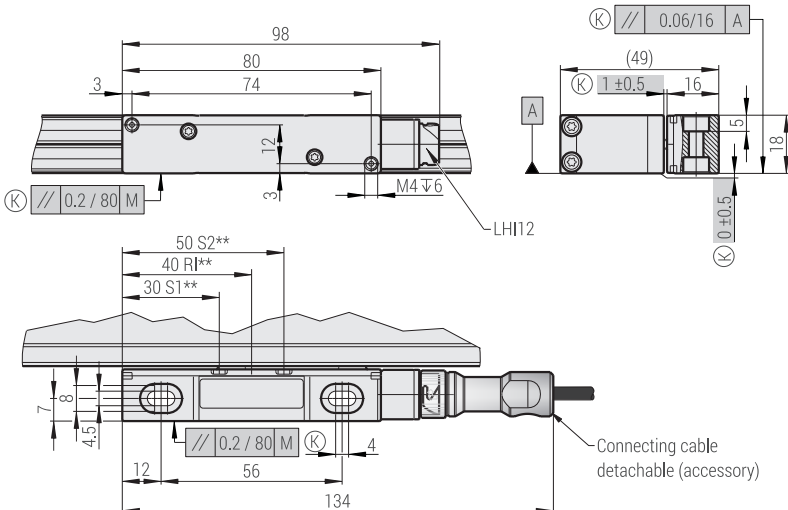

- M = Machine guideway
- ML = Measuring length
- G = Gauging points
- ← → = 0 ... ML
- OL = Overall length
- C = Cable

LH12 = Male connector

- (K) = Required mating dimensions
- (S) = Beginning of the measuring length

#### OPTIONAL:

- S1, S2 = Switch signals
- RI = Selectable reference mark
- \* = Actuator magnet
- \*\* = Position sensor

mm  
  
 Tolerancing ISO 8015  
 ISO 2768: 1989 - m H  
 < 6 mm: ±0.2 mm





## MSA 720, MSA 820

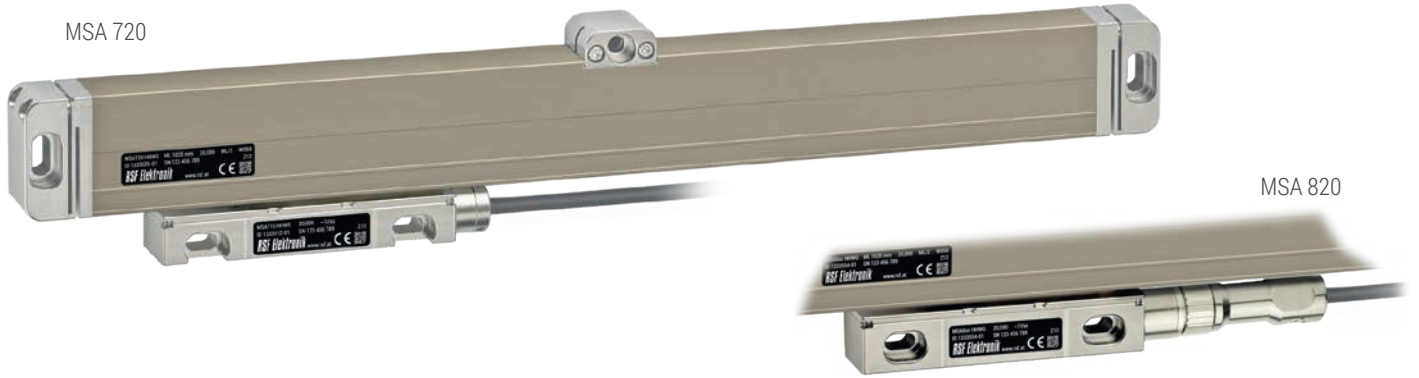

### Dimensions, mounting tolerances MSA 720:

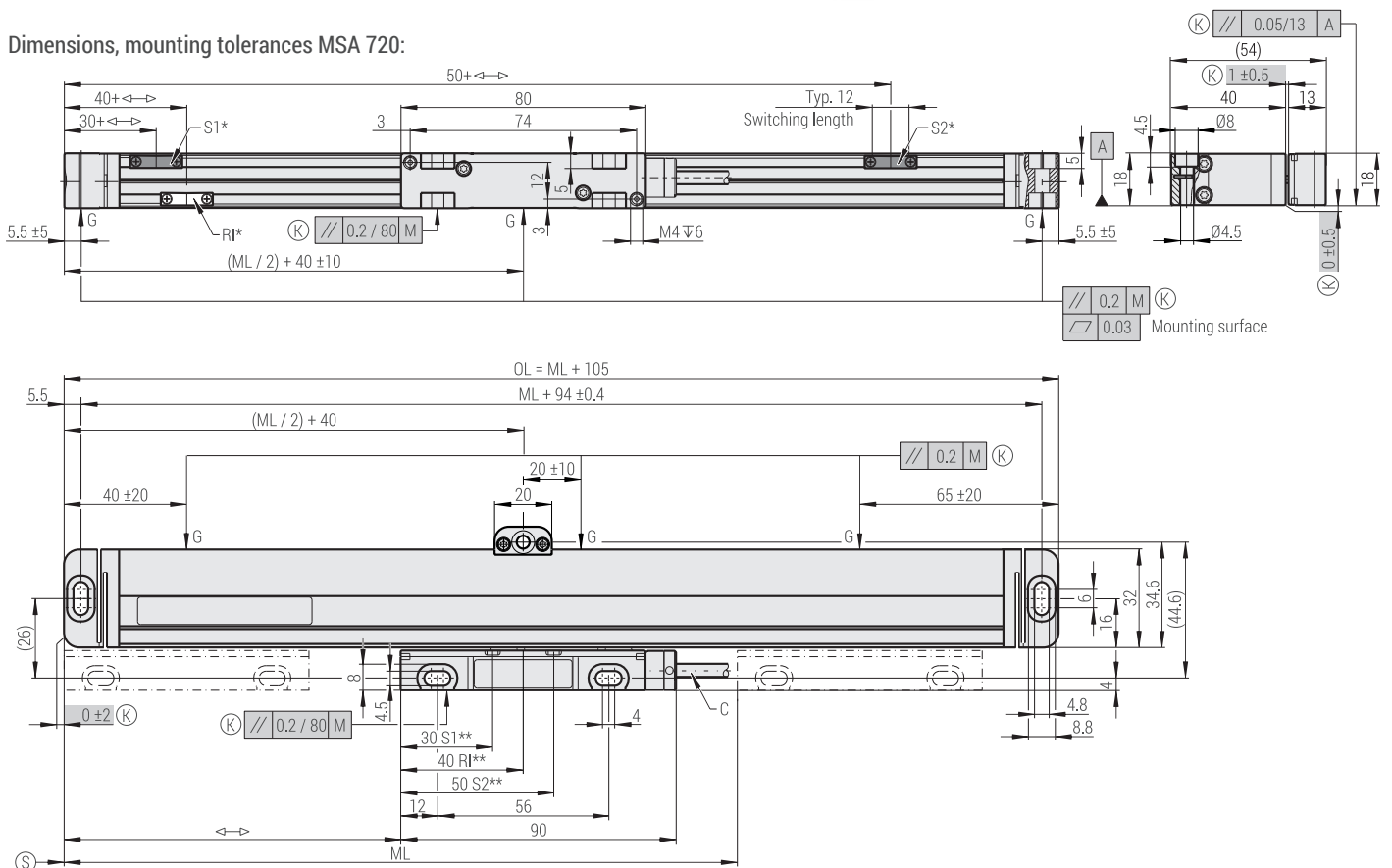

### Dimensions, mounting tolerances MSA 820:

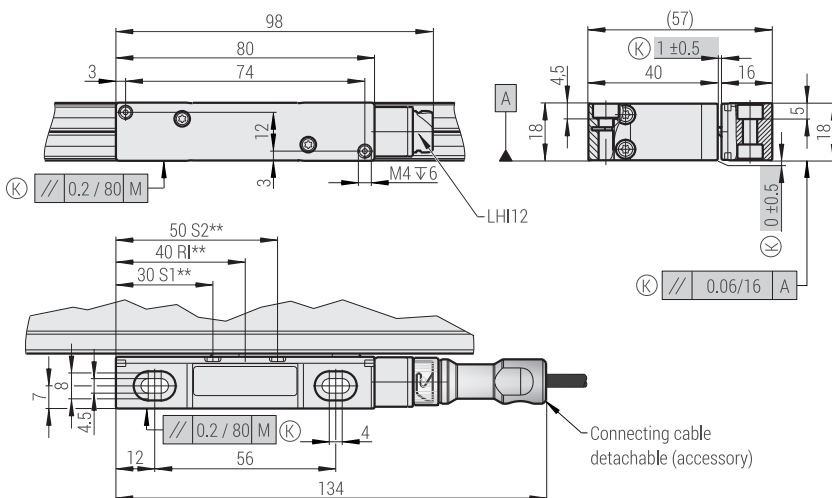

- M = Machine guideway
- ML = Measuring length
- G = Gauging points
- ← → = 0 ... ML
- OL = Overall length
- C = Cable

LH12 = Male connector

- (K) = Required mating dimensions
- (S) = Beginning of the measuring length

#### OPTIONAL:

- S1, S2 = Switch signals
- RI = Selectable reference mark
- \* = Actuator magnet
- \*\* = Position sensor

mm



Tolerancing ISO 8015  
ISO 2768: 1989 - m H  
< 6 mm: ±0.2 mm

# MSA 730, MSA 830



Dimensions, mounting tolerances MSA 730:

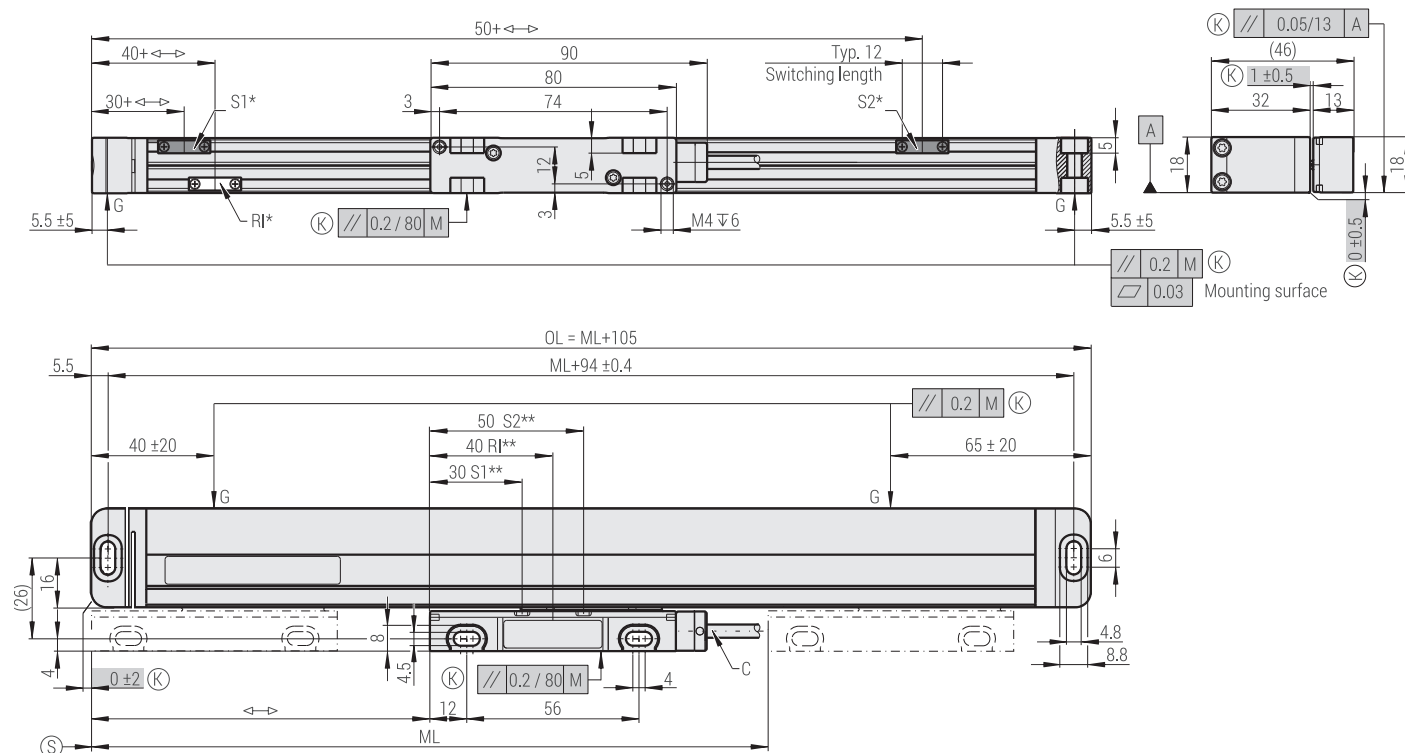

Dimensions, mounting tolerances MSA 830:

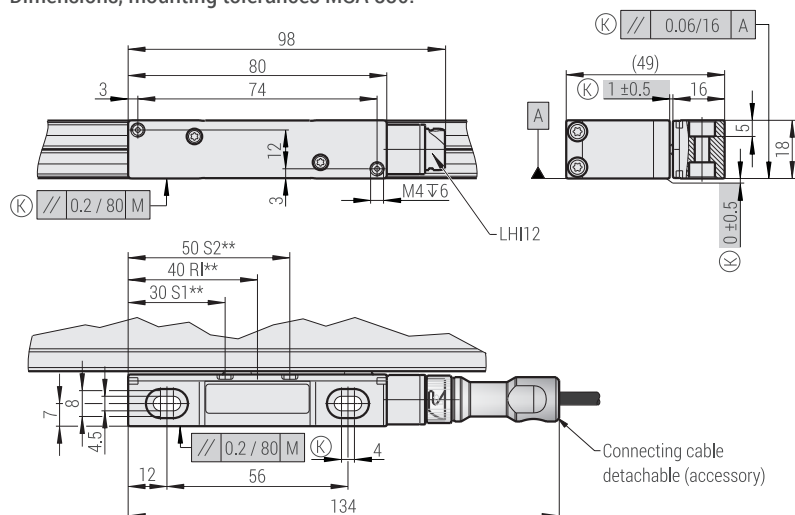

- M = Machine guideway
- ML = Measuring length
- G = Gauging points
- ↔ = 0 ... ML
- OL = Overall length
- C = Cable

LHI12 = Male connector

- (K) = Required mating dimensions
- (S) = Beginning of the measuring length

- OPTIONAL:
- S1, S2 = Switch signals
  - RI = Selectable reference mark
  - \* = Actuator magnet
  - \*\* = Position sensor

mm  
  
 Tolerancing ISO 8015  
 ISO 2768: 1989 - m H  
 < 6 mm: ±0.2 mm

## DISTRIBUTION CONTACTS

AUSTRIA <i>Corporate Head Quarters</i>	RSF Elektronik Ges.m.b.H.	A-5121 Tarsdorf 93	☎ +43 62 78 81 92-0 FAX +43 62 78 81 92-79	e-mail: info@rsf.at internet: www.rsf.at
BELGIUM	HEIDENHAIN NV/SA	Pamelse Klei 47 1760 Roosdaal	☎ +32 (54) 34 3158 FAX +32 (54) 34 3173	e-mail: sales@heidenhain.be internet: www.heidenhain.be
FRANCE	HEIDENHAIN FRANCE sarl	2 Avenue de la Christallerie 92310 Sèvres	☎ +33 1 41 14 30 00 FAX +33 1 41 14 30 30	e-mail: info@heidenhain.fr internet: www.heidenhain.fr
GREAT BRITAIN	HEIDENHAIN (GB) Ltd.	200 London Road Burgess Hill West Sussex RH15 9RD	☎ +44 1444 247711 FAX +44 1444 870024	e-mail: sales@heidenhain.co.uk internet: www.heidenhain.co.uk
ITALY	HEIDENHAIN ITALIANA S.r.l.	Via Asiago, 14 20128 Milan	☎ +39 02 27075-1 FAX +39 02 27075-210	e-mail: info@heidenhain.it internet: www.heidenhain.it
NETHERLANDS	HEIDENHAIN NEDERLAND B.V.	Copernicuslaan 34 6716 BM EDE	☎ +31 318-581800 FAX +31 318-581870	e-mail: verkoop@heidenhain.nl internet: www.heidenhain.nl
SPAIN	FARRESA ELECTRONICA S.A	Les Corts 36-38 08028 Barcelona	☎ +34 93 4 092 491 FAX +34 93 3 395 117	e-mail: farresa@farresa.es internet: www.farresa.es
SWEDEN	HEIDENHAIN Scandinavia AB	Rosterigränd 16 SE-117 61 Stockholm	☎ +46 8 531 933 50 FAX +46 8 531 933 77	e-mail: sales@heidenhain.se internet: www.heidenhain.se
SWITZERLAND	HEIDENHAIN (SCHWEIZ) AG	Vieristrasse 14 8603 Schwerzenbach	☎ +41 44 806 27 27 FAX +41 44 806 27 28	e-mail: verkauf@heidenhain.ch internet: www.heidenhain.ch
CHINA	DR. JOHANNES HEIDENHAIN (CHINA) Co., Ltd	Tian Wei San Jie, Area A, Beijing Tianzhu Airport Industrial Zone Shunyi District, Beijing 101312	☎ +86 10 80 42-0000	e-mail: sales@heidenhain.com.cn internet: www.heidenhain.com.cn
ISRAEL	MEDITAL Hi-Tech	36 Shacham St., P.O.Box 7772 4951729 Petach Tikva	☎ +972 0 3 923 33 23 FAX +972 0 3 923 16 66	e-mail: avi@medital.co.il internet: www.medital.co.il
JAPAN	HEIDENHAIN K.K.	Hulic Kojimachi Bldg., 9F 3-2 Kojimachi, Chiyoda-ku Tokyo, 102-0083	☎ +81 3 3234 7781 FAX +81 3 3262 2539	e-mail: sales@heidenhain.co.jp internet: www.heidenhain.co.jp
KOREA	HEIDENHAIN LTD.	75, Jeonpa-ro 24beon-gil, Manan-gu, Anyang-si 14087 Gyeonggi-do	☎ +82 31 380 5200 FAX +82 31 380 5250	e-mail: info@heidenhain.co.kr internet: www.heidenhain.co.kr
SINGAPORE	HEIDENHAIN PACIFIC PTE LTD.	51, Ubi Crescent 408593 Singapore	☎ +65 67 49 32 38 FAX +65 67 49 39 22	e-mail: info@heidenhain.com.sg internet: www.heidenhain.com.sg
TAIWAN	HEIDENHAIN CO., LTD.	No. 29, 33rd Road; Taichung Industrial Park Taichung 40768	☎ +886 4 2358 89 77 FAX +886 4 2358 89 78	e-mail: info@heidenhain.tw internet: www.heidenhain.com.tw
USA	HEIDENHAIN CORPORATION	333 East State Parkway Schaumburg, IL 60173-5337	☎ +1 847 490 11 91	e-mail: info@heidenhain.com internet: www.heidenhain.com

Date 06/2024 ■ Art.No.1340379-01 ■ Doc.No. D1340379-01-F-01 ■ Technical adjustments in reserve!



# RSF Elektronik

Ges.m.b.H.

Linear and Angle Encoders  
Precision Graduations

Certified acc. to  
ISO 9001  
ISO 14001

