

- H1 = Kappe FOKAA1= H
Cover FOKAA1= H
- H2 = Kappe FOKAA1= SH
Cover FOKAA1= SH
- H3 = Stiflleiste 15-pol. axial
Plug connector 15 pin axial
- H4 = Stiflleiste 15-pol. radial
Plug connector 15 pin radial
- H5 = Zugentlastung FOKAA1=SC / SH
Strain relief FOKAA1= SC / SH
- H6 = Bügel in Montagestellung
slide pulled out in mounting position
- H7 = Max. Maß für FOKAA1= C / SC
Max. dim. FOKAA1= C / SC
- H8 = Erforderlicher Einbauraum
Required installation space
- H9 = Nabenbefestigung
Zentrierung durch
-Tellerfeder 733484-01
-M5,0x10 Id.-Nr. 200507-6F
Anzugsmoment 3,5±0,25 Nm
Nabenklebung Loctite 290
siehe Arbeitsanweisung D1310821
Hub centering through
-diaphragm spring 733484-01
-M5,0x10 Id.-Nr. 200507-6F
torque 3,5±0,25 Nm
hub bonding Loctite 290
see work instructions D1310821
- H10 = Befestigungsschraube
- M2,5 x 5,25 Id.-Nr. 548595-02 Torx T8
- #2-56 UNC x 5,25 Id.-Nr. 548595-03 Torx T8
Anzugsmoment 0,21 ±0,02 Nm
Mounting screw
- M2,5 x 5,25 Id.-Nr. 548595-02 Torx T8
- #2-56 UNC x 5,25 Id.-Nr. 548595-03 Torx T8
torque 0,21 ±0,02 Nm
- H11 = Maßangabe für JH-Standardkabel
Dimension for JH-standard cable
- H12 = Ausgleich von Montagetoleranzen und thermischer Ausdehnung
Compensation of mounting tolerances and thermal expansion
- H13 = Referenzmarken-Lage ±10°
Referenze mark position ±10°
- H14 = Drehrichtung der Welle für Ausgangssignale gemäß Schnittstellen-Beschreibung
Direction of shaft rotation for output signals according to interface-description

- A = Lagerung Kundenwelle
Bearing for customer shaft
- K = Kundenseitige Anschlussmaße
Required mating dimensions
- M = Messpunkte Arbeitstemperatur
Operating temperature measuring points

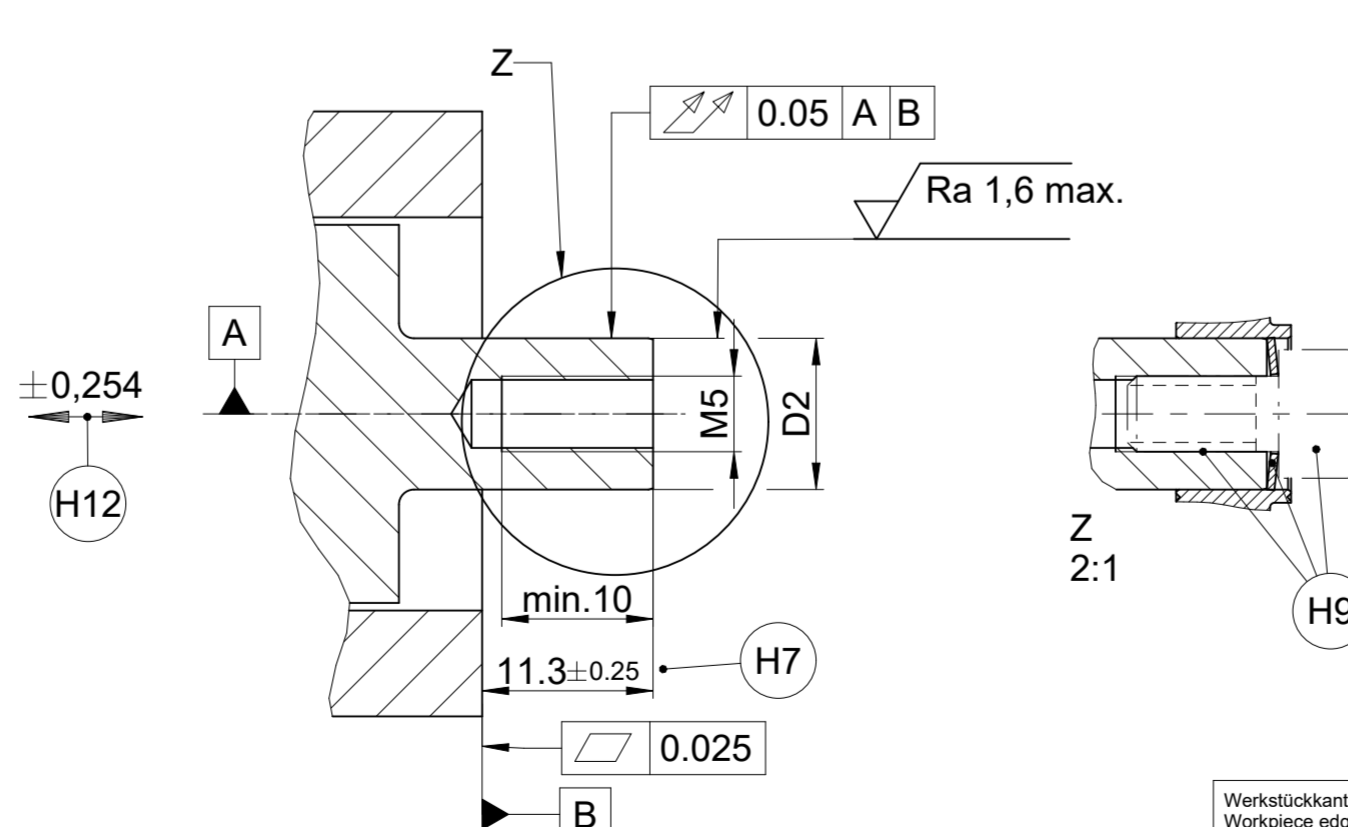
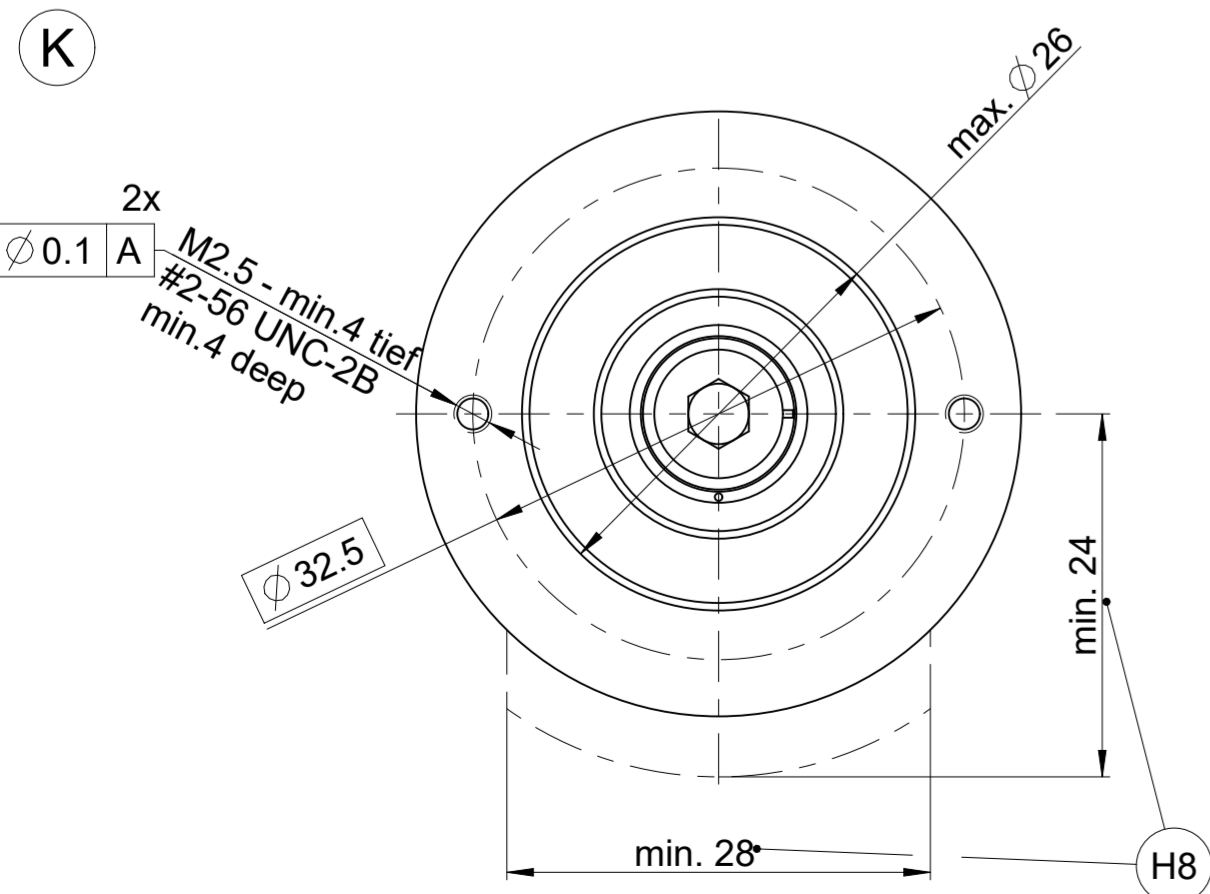

R35i	C/H/SC/SH	10	1PA	Ø 10	Ø 9,99
NAMEA1	FOKAA1	NADUA1	WELLA1	D1 ^{+0,01} ⊖	D2 ^{-0,013} ⊖

Original drawing		R35i RENCO NADUA1=10 WELLA1=1PA		ID number:	C112481-30
Scale	Format	R35i		Change No.	Serie
2:1	A2	Anschlussmaße / Mating Dimensions		Phase:	
Dimensions in mm				Tolerierung nach DIN ISO 8015	
				Allgemeintol. ISO 2768-mH ±0,2	
				General tol. ISO 2768-mH ±0,2	
The reproduction, distribution and utilization of this document as well as the communication of its contents to others without express authorization is prohibited. Offenders will be held liable for the payment of damages. All rights reserved in the event of the grant of a patent, utility model or design. (ISO 16016)					
HEIDENHAIN DR. JOHANNES HEIDENHAIN GmbH 83301 Traunreut, Germany				Version	Revision
				Sheet	Page
				1	1
				D1326571-00-A-01	
				Document number	