



R35i and R35iL Rotary Encoders

www.renco.com

RENCO R35i and R35iL rotary encoders

The RENCO R35i is an incremental optical rotary encoder without an integral bearing. Its key features include a compact design, with a 35 mm outer diameter and a height of 14 mm, and a built-in mounting aid for convenient self-centering installation. In conjunction with its OPTO-ASIC technology, the RENCO R35i offers optimal functionality in a highly compact design.

For an even flatter footprint, RENCO also offers the R35iL rotary encoder, featuring a low height of only 8.6 mm.

Key features of the new generation of RENCO rotary encoders:

- Built-in signal monitoring and visual indicator in the event of a malfunction (red LED)
- Position feedback at a very high resolution of up to 40 000 measuring steps per revolution
- Highly accurate output of the UVW track sequence for motors with up to 32 pole pairs
- Electronic adjustment of the motor commutation
- Electronic ID label: ID number, serial number and OEM memory
- Wide operating temperature range of $-30\text{ }^{\circ}\text{C}$ to $+115\text{ }^{\circ}\text{C}$

Inspecting the rotary encoder for proper mounting and functioning, as well as adjusting it, with the PWT 101:

- Mounting inspection
- Output signals
- Signal level
- Counts
- Commutation offset
- Encoder information
- Reading/writing to OEM memory



PWT 101



This brochure supersedes all previous editions, which thereby become invalid. The basis for ordering from HEIDENHAIN is always the brochure edition valid when the order is placed.

Standards (ISO, EN) apply only where explicitly stated in this brochure.

Contents

Areas of application		
	Electric motor technology	4
	Robotics	4
	Medical technology	4
	Automation	5
	Facility engineering	5
Selection guide		
	R35i	6
	R35iL	7
Specifications		
	R35i rotary encoders with Ø 32.5 mm flange	8
	R35i rotary encoders with Ø 46.0 mm flange	10
	R35i rotary encoders with synchro flange (resolver size 15)	12
	R35iL rotary encoders	14
Electrical connection		
	General electrical information	16
	LD square-wave signals	19
	PP square-wave signals	21
	Output cables	23
Mounting		
	General mechanical information	25
	Mounting the R35i	26
	Mounting the R35iL	27
	Adjustment for motor commutation	28
	Mounting accessories	30
Testing equipment and diagnostics		
	PWT 101	31
	Block commutation	31
	Miscellaneous testing accessories	31

Areas of application

The RENCO R35i is an incremental optical rotary encoder without an integral bearing. Its key features include a compact design, with a 35 mm outer diameter and a height of 14 mm, and a built-in mounting aid for convenient self-centering installation. In conjunction with its OPTO-ASIC technology, the RENCO R35i offers optimal functionality in a highly compact design, making it ideal for the following areas of application:

Electric motor technology

Thanks to its high position measurement resolution of up to 10000 signals per revolution (40000 measuring steps after fourfold evaluation) and its wide operating temperature range, from $-30\text{ }^{\circ}\text{C}$ to $+115\text{ }^{\circ}\text{C}$, the RENCO R35i is an ideal feedback system for stepper motors in Closed Loop mode. The RENCO R35i also provides three commutation signals (U, V, and W) for the positionally correct powering of the rotor windings in BLDC motors (brushless DC motors) with up to 32 pole pairs.

Robotics

The robotics industry is growing rapidly. Recent technologies in the field are opening up new areas of application well beyond the typical industrial robots used in automated manufacturing. In the future, service robots capable of direct human interaction will increasingly assist in manual production processes. Professional service robots will also find a growing use in applications such as

- building-facade and solar-panel cleaning,
- pipeline inspection,
- fully automated agricultural harvesting
- and logistics, in the form of automated conveyor and loading vehicles.

Thanks to its compact design and outstanding performance data, the RENCO R35i is the ideal solution for all such applications.

Medical technology

A variety of characteristics make the RENCO R35i an excellent solution for demanding medical technology applications. Its materials are RoHS-conformant and therefore free of hazardous materials in accordance with EC Directive 2011/65/EU. It also features high reliability and interference-free data transmission thanks to line drivers in compliance with EIA standard RS-422. These characteristics play a key role in attaining high patient safety in physiotherapeutic devices, as well as high analysis quality and reproducibility in laboratory applications. The encoder's high resolution of up to 10000 signal periods per revolution enables gentle, smooth, and precise control, which is important for liquid-handling lab applications and for patient comfort in physiotherapeutic devices. Typical areas of application include lab automation equipment with centrifuges and pipetting systems for liquid handling, as well as physiotherapeutic devices such as movement exercisers.



Automation

The RENCO R35i is an attractive solution for automation applications in industries such as semiconductors, food and textiles. With its strong dynamic performance and very high signal resolution, this encoder excels in precise position control of machines and complex systems. Die bonders for chip-on-board manufacturing, automated textile winding machines, palleting systems, and automated coin counters are just a few of the possible applications. Short signal processing times give the RENCO R35i its high dynamic performance, while its integrated interpolation provides high resolution for precise positioning. Of course, the compact design of the R35i, made possible by its ASIC technology, also plays a significant role in factory automation.

Facility engineering

Modern residential, administrative and industrial buildings contain numerous motor-controlled systems, including elevators, ventilation systems and automatic doors and gates. The compact design of the RENCO R35i makes it ideal for applications such as elevator door control and speed control in ventilation systems.

Facility engineering providers place great value on reliability and failure safety. These qualities are ensured thanks to extensive certification of the encoders in accordance with ISO quality standards. Reliable data transfer is ensured by the encoder's serial interface in accordance with the EIA standard RS-422. This interface ensures high immunity to interference through its symmetrical differential signal transmission.

As a particularly low-profile and low-weight alternative to the R35i, RENCO also offers the R35iL rotary encoder. It can be used in the same types of applications but, thanks to its low height of just 8.6 mm, lends itself particularly to applications with critical installation parameters and limited space. Even with its low footprint, the RENCO R35iL still offers state-of-the-art performance capabilities. These include a resolution of up to 5000 signals per revolution, commutation signals (U, V, and W) and an operating temperature range of $-30\text{ }^{\circ}\text{C}$ to $+115\text{ }^{\circ}\text{C}$. With its integrated mounting aid, the R35iL is also equipped for convenient, self-centering installation. The R35iL runs on a supply voltage of either 3.3 V or 5 V.

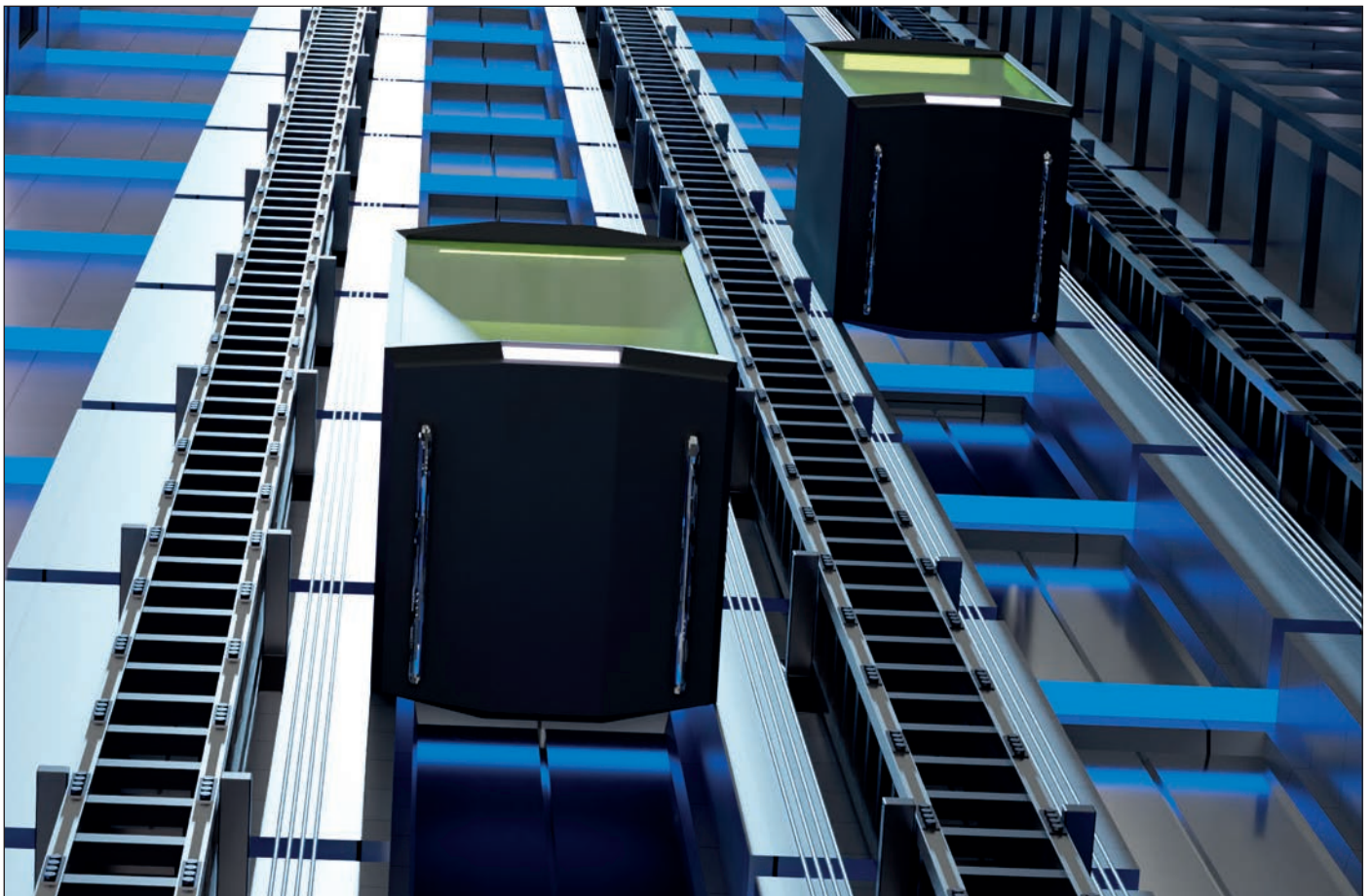

R35i and R35iL selection guide

R35i ordering key

R35i-10000/4-6mm-LD/LD-5V-1-R-C-M

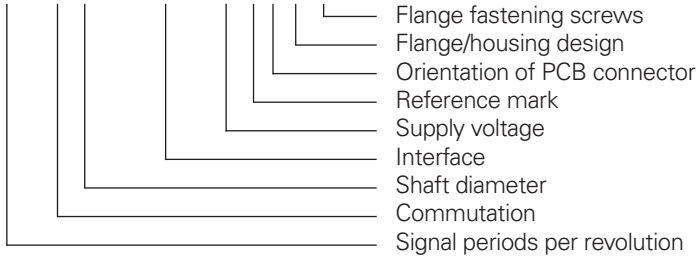

Selection table

Signal periods per revolution	100, 200, 250, 256, 400, 500, 512, 625, 800, 1000, 1024, 1250, 2000, 2048, 2500, 4000, 4096, 5000, 8000, 8192, 10000		
Commutation	0	Without commutation	
	2 to 32	Number of commutation signal periods per revolution (2x number of motor pole pairs)	
Shaft diameter	Metric	3 mm, 4 mm, 5 mm, 6 mm, 8 mm	
	Inch	1/8, 1/8+, 3/16, 3/16+, 1/4, 1/4+, 5/16, 5/16+, 3/8, 3/8+	
Interface	LD	Square-wave signals with differential line driver as per RS-422	
	PP	Square-wave signals with push-pull driver output	
Supply voltage	5 V	+5 V ±10 %	
Reference mark	1	Width: 90° ±45° elec.	Gate: U _{a1} High and U _{a2} High
	6	Width: 90° ±45° elec.	Gate: U _{a1} Low and U _{a2} Low
	7	Width: 270° ±45° elec.	Gate: U _{a1} High and U _{a2} High
	8	Width: 270° ±45° elec.	Gate: U _{a1} Low and U _{a2} Low
PCB connector	R	Radial	
	A	Axial	
Flange and housing design	C, SC*	Flange with Ø 32.5 mm fastening screw circle, closed housing	
	H, SH*	Flange with Ø 32.5 mm fastening screw circle, housing with central hole	
	C4, SC4*	Flange with Ø 46.0 mm fastening screw circle, closed housing	
	H4, SH4*	Flange with Ø 46.0 mm fastening screw circle, housing with central hole	
	CR, SCR*	Synchro flange; resolver size 15; closed housing	
	HR, SHR*	Synchro flange; resolver size 15; closed housing	
Flange fastening screws	M	Metric	
	U	UNC	

* Housing with strain relief connection for the output cable



Housing with central hole and strain relief



Closed housing with strain relief



Housing with central hole

R35iL ordering key

R35iL-5000/4-6mm-PP/PP-5V-1-R-.-M

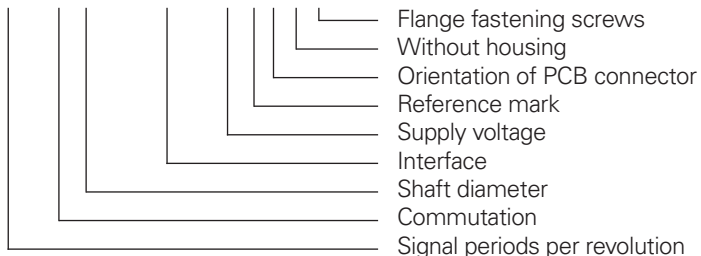

Selection table

Signal periods per revolution	100, 200, 250, 256, 400, 500, 512, 625, 800, 1000, 1024, 1250, 2000, 2048, 2500, 4000, 4096, 5000		
Commutation	0 2 to 32	Without commutation Number of commutation signal periods per revolution (≙ number of motor pole pairs)	
Shaft diameter	Metric Inch	3 mm, 4 mm, 5 mm, 6 mm, 8 mm 1/8+, 3/16, 3/16+, 1/4, 1/4+, 5/16, 3/8, 3/8+	
Interface	PP	Square-wave signals with push-pull driver output	
Supply voltage	3.3 5 V	3.3 V ±5 % +5 V ±10 %	
Reference mark	1 6 7 8	Width: 90° ±45° elec. Width: 90° ±45° elec. Width: 270° ±45° elec. Width: 270° ±45° elec.	Gate: U _{a1} High and U _{a2} High Gate: U _{a1} Low and U _{a2} Low Gate: U _{a1} High and U _{a2} High Gate: U _{a1} Low and U _{a2} Low
PCB connector	R	Radial	
Housing design	.. C, SC* H, SH*	Without housing Closed housing with central hole	
Flange fastening screws	M U	Metric UNC	

* Housing with strain relief connection for the output cable



Closed housing

Packaging unit

The rotary encoders are available in a package size of **10 units**. Rotary encoder housings and mounting materials are included (flange fastening screws and offset screwdriver for shaft fastening).

R35i rotary encoders

Incremental rotary encoders

- Ø 32.5 mm flange for axial mounting
- Hollow through shaft
- Self-centering, without integral bearing



Housing with central hole (H)

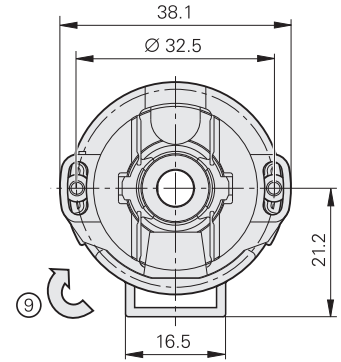
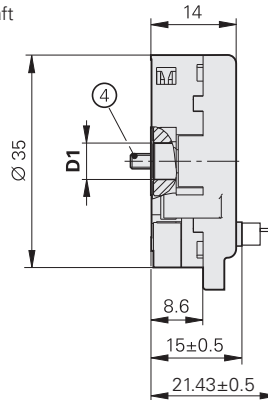
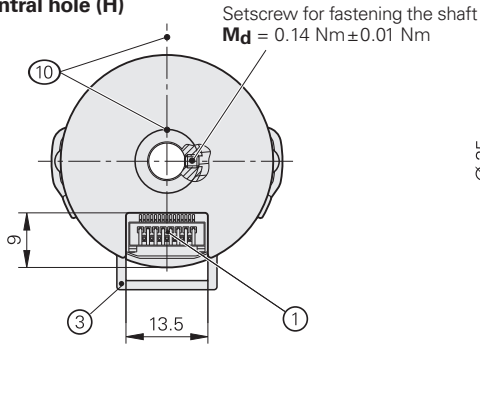

Closed housing (C)

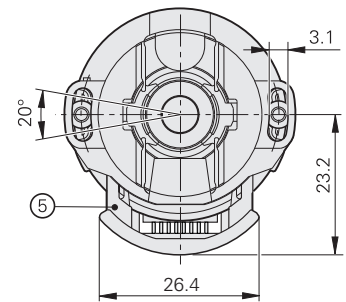
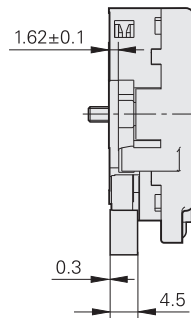
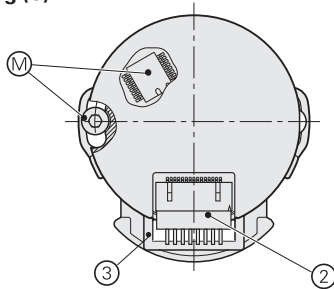

Required mating dimensions

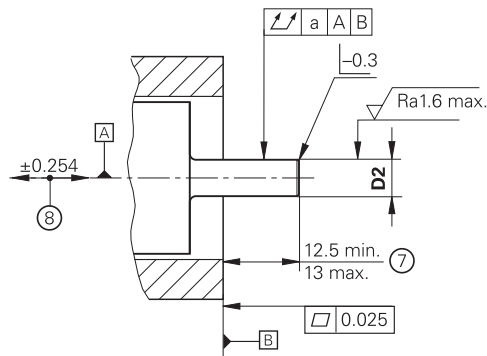
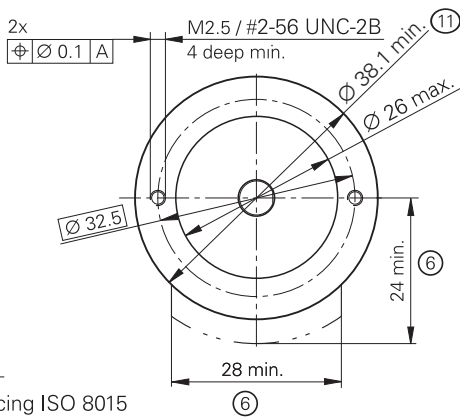

Signal periods	$\frac{\Delta}{a}$
≤ 5000	0.05
> 5000	0.03
≤ 10000	0.03

mm
Tolerancing ISO 8015
ISO 2768:1989-mH
≤ 6 mm: ±0.2 mm

- ▢ = Bearing of mating shaft
- M = Measuring point for operating temperature
- 1 = 15-pin axial header
- 2 = 15-pin radial header
- 3 = Housing with strain relief (SH/SC)
- 4 = Torx T8 fastening screws for flange:
2x M2.5x5.25 (ID 548595-02) or 2x #2-56 UNCx5.25 (ID 548595-03);
tightening torque: 0.21 Nm ± 0.02 Nm
- 5 = Slide lock in mounting position
- 6 = Required installation space for slide lock in mounting position
- 7 = Max. dimension for closed housing (C/SC)
- 8 = Maximum permissible motion between shaft and stator (including thermal expansion);
dynamic axial motion is permitted over the entire value
- 9 = Direction of shaft rotation for ascending position values
- 10 = Reference mark position ±10°
- 11 = Flange surface; ensure full-surface contact in the area around the holes for the screws

*) Shaft diameter in inches and mm

Setscrew socket	*)	D1 $\begin{matrix} +0.01 \\ 0 \end{matrix}$ E	D2 $\begin{matrix} 0 \\ -0.013 \end{matrix}$ E
SW 0.89 Hex	3/8+	Ø 9.528	Ø 9.525
	3/8	Ø 9.520	Ø 9.517
0.048" Bristol 4-Spine	8 mm	Ø 8	Ø 7.997
	5/16+	Ø 7.940	Ø 7.937
	5/16	Ø 7.932	Ø 7.929
	1/4+	Ø 6.353	Ø 6.350
	1/4	Ø 6.345	Ø 6.342
	6 mm	Ø 6	Ø 5.997
	5 mm	Ø 5	Ø 4.997
	3/16+	Ø 4.765	Ø 4.762
	3/16	Ø 4.757	Ø 4.754
	4 mm	Ø 4	Ø 3.997
	1/8+	Ø 3.178	Ø 3.175
	1/8	Ø 3.170	Ø 3.167
	3 mm	Ø 3	Ø 2.997

R35i					
Interface*	LD/0	PP/0	LD/LD	LD/PP	PP/PP
Signal periods per rev.*	100, 200, 250, 256, 400, 500, 512, 625, 800, 1000, 1024, 1250, 2000, 2048, 2500, 4000, 4096, 5000, 8000, 8192, 10000 Metal graduation: up to 5000; glass graduation: over 5000				
Reference mark Width / Gate*	One 1 Width: 90° ±45° elec. Gate: U _{a1} High and U _{a2} High 6 Width: 90° ±45° elec. Gate: U _{a1} Low and U _{a2} Low 7 Width: 270° ±45° elec. Gate: U _{a1} High and U _{a2} High 8 Width: 270° ±45° elec. Gate: U _{a1} Low and U _{a2} Low				
Output frequency	≤ 1.83 MHz				
Commutation Signal periods per rev.*	Without 0		Signal tracks U, V, W 2 to 32		
System accuracy ¹⁾	Metal graduation: ±300" Glass graduation: ±150"				
Electrical connection Connection orientation*	15-pin PCB connector R = Radial, A = Axial				
Supply voltage	DC 5 V ±0.5 V				
Current consumption Typically 5 V, without load Max. 5.5 V, without load Max. 5.5 V, with load	≤ 45 mA ≤ 105 mA ≤ 205 mA	≤ 45 mA ≤ 95 mA ≤ 105 mA	≤ 45 mA ≤ 110 mA ≤ 310 mA	≤ 45 mA ≤ 105 mA ≤ 210 mA	≤ 45 mA ≤ 95 mA ≤ 115 mA
Shaft*	Hollow through shaft with radial clamping Shaft diameter: See <i>Mating dimensions</i>				
Mech. permissible speed	Metal graduation: ≤ 30000 rpm Glass graduation: ≤ 12000 rpm				
Moment of inertia of rotor	Metal graduation: 0.2 · 10 ⁻⁶ kgm ² Glass graduation: 0.3 · 10 ⁻⁶ kgm ²				
Permissible motion of measured shaft	Axial: ±0.254 mm Radial runout: 0.05 mm TIR (≤ 5000 signal periods per rev.) 0.03 mm TIR (> 5000 signal periods per rev.)				
Vibration 55 Hz to 2000 Hz Shock: 6 ms	≤ 200 m/s ² (EN 60068-2-6) ≤ 2000 m/s ² (EN 60068-2-27)				
Operating temperature	-30 °C to 115 °C				
Relative humidity	≤ 93% (40 °C/21 d as per EN 60068-2-78), without condensation				
Protection rating EN 60529	IP30 ²⁾				
Mass	≈ 0.03 kg				
ID number	1064590-xx	1282231-xx	1188619-xx	1282244-xx	1282236-xx

* Please select when ordering

¹⁾ When mounted; additional errors due to mounting of the measured shaft are not considered.
For a measured shaft eccentricity of 1 µm, the measuring error increases by ±16.4"

²⁾ Electromagnetic compatibility must be ensured in the complete system.

R35i rotary encoders

Incremental rotary encoders

- Ø 46.03 mm flange for axial mounting
- Hollow through shaft
- Self-centering, without integral bearing



Housing with central hole (H4)

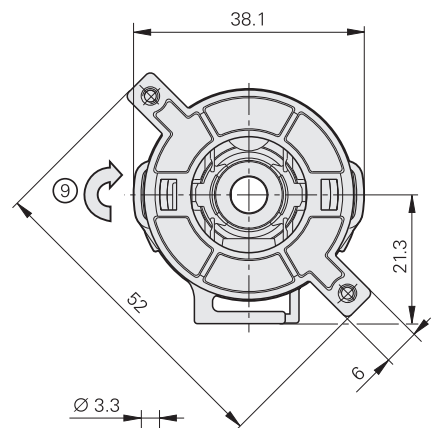
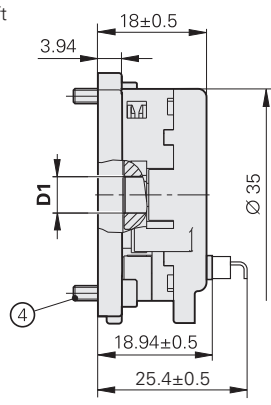
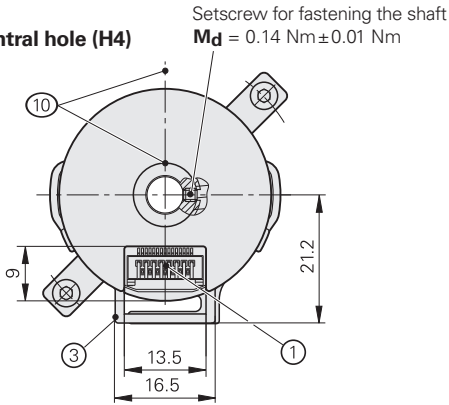

Closed housing (C4)

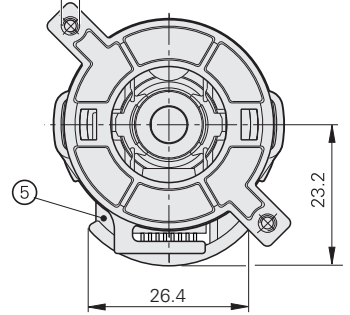
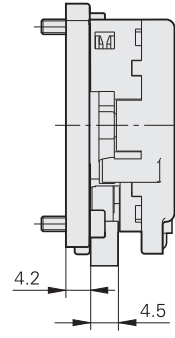
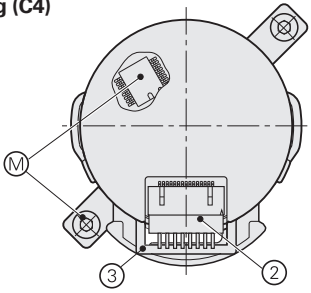

Required mating dimensions

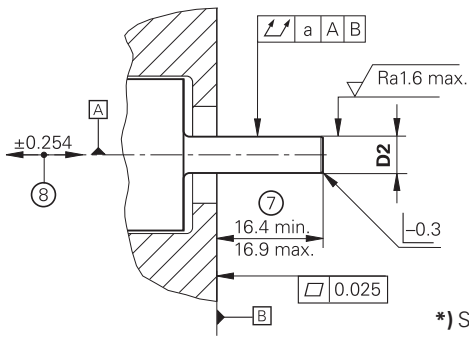
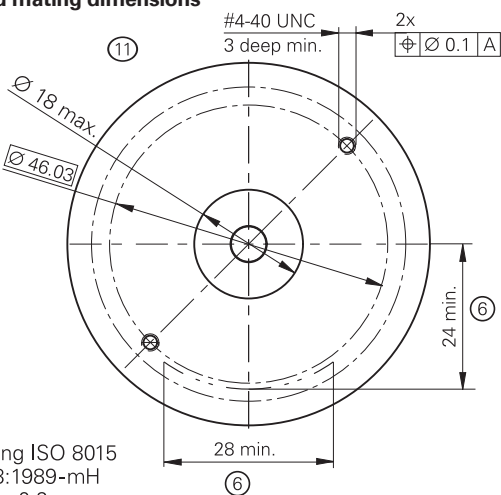

Signal periods	\sqrt{a}
≤ 5000	0.05
> 5000 ≤ 10000	0.03

mm
Tolerancing ISO 8015
ISO 2768:1989-mH
≤ 6 mm: ±0.2 mm

- ☒ = Bearing of mating shaft
- M = Measuring point for operating temperature
- 1 = 15-pin axial header
- 2 = 15-pin radial header
- 3 = Housing with strain relief (SH4/SC4)
- 4 = Fastening screws, width A/F 3/32", hex, for flange:
2x #4-40 UNCx6.35 (ID 200507-A0); tightening torque: 0.21 Nm ± 0.02 Nm
- 5 = Slide lock in mounting position
- 6 = Required installation space for slide lock in mounting position
- 7 = Max. dimension for closed housing (C4/SC4)
- 8 = Maximum permissible motion between shaft and stator (including thermal expansion);
dynamic axial motion is permitted over the entire value
- 9 = Direction of shaft rotation for ascending position values
- 10 = Reference mark position ± 10°
- 11 = Flange surface; ensure full-surface contact in the area around the holes for the screws

*) Shaft diameter in inches and mm

Setscrew socket	*)	D1 +0.01 0	D2 0 -0.013
SW 0.89 Hex	3/8+	Ø 9.528	Ø 9.525
	3/8	Ø 9.520	Ø 9.517
0.048" Bristol 4-Spine	8 mm	Ø 8	Ø 7.997
	5/16+	Ø 7.940	Ø 7.937
	5/16	Ø 7.932	Ø 7.929
	1/4+	Ø 6.353	Ø 6.350
	1/4	Ø 6.345	Ø 6.342
	6 mm	Ø 6	Ø 5.997
	5 mm	Ø 5	Ø 4.997
	3/16+	Ø 4.765	Ø 4.762
	3/16	Ø 4.757	Ø 4.754
	4 mm	Ø 4	Ø 3.997
	1/8+	Ø 3.178	Ø 3.175
	1/8	Ø 3.170	Ø 3.167
3 mm	Ø 3	Ø 2.997	

R35i					
Interface*	LD/0	PP/0	LD/LD	LD/PP	PP/PP
Signal periods per rev.*	100, 200, 250, 256, 400, 500, 512, 625, 800, 1000, 1024, 1250, 2000, 2048, 2500, 4000, 4096, 5000, 8000, 8192, 10000 Metal graduation: up to 5000; glass graduation: over 5000				
Reference mark Width / Gate*	One 1 Width: 90° ±45° elec. Gate: U _{a1} High and U _{a2} High 6 Width: 90° ±45° elec. Gate: U _{a1} Low and U _{a2} Low 7 Width: 270° ±45° elec. Gate: U _{a1} High and U _{a2} High 8 Width: 270° ±45° elec. Gate: U _{a1} Low and U _{a2} Low				
Output frequency	≤ 1.83 MHz				
Commutation Signal periods per rev.*	Without 0		Signal tracks U, V, W 2 to 32		
System accuracy ¹⁾	Metal graduation: ±300" Glass graduation: ±150"				
Electrical connection Connection orientation*	15-pin PCB connector R = Radial, A = Axial				
Supply voltage	DC 5 V ±0.5 V				
Current consumption Typically 5 V, without load Max. 5.5 V, without load Max. 5.5 V, with load	≤ 45 mA ≤ 105 mA ≤ 205 mA	≤ 45 mA ≤ 95 mA ≤ 105 mA	≤ 45 mA ≤ 110 mA ≤ 310 mA	≤ 45 mA ≤ 105 mA ≤ 210 mA	≤ 45 mA ≤ 95 mA ≤ 115 mA
Shaft*	Hollow through shaft with radial clamping Shaft diameter: See <i>Mating dimensions</i>				
Mech. permissible speed	Metal graduation: ≤ 30000 rpm Glass graduation: ≤ 12000 rpm				
Moment of inertia of rotor	Metal graduation: 0.2 · 10 ⁻⁶ kgm ² Glass graduation: 0.3 · 10 ⁻⁶ kgm ²				
Permissible motion of measured shaft	Axial: ±0.254 mm Radial runout: 0.05 mm TIR (≤ 5000 signal periods per rev.) 0.03 mm TIR (> 5000 signal periods per rev.)				
Vibration 55 Hz to 2000 Hz Shock: 6 ms	≤ 200 m/s ² (EN 60068-2-6) ≤ 2000 m/s ² (EN 60068-2-27)				
Operating temperature	-30 °C to 115 °C				
Relative humidity	≤ 93% (40 °C/21 d as per EN 60068-2-78), without condensation				
Protection rating EN 60529	IP30 ²⁾				
Mass	≈ 0.03 kg				
ID number	1064590-xx	1282231-xx	1188619-xx	1282244-xx	1282236-xx

* Please select when ordering

¹⁾ When mounted; additional errors due to mounting of the measured shaft are not considered.
For a measured shaft eccentricity of 1 µm, the measuring error increases by ±16.4"

²⁾ Electromagnetic compatibility must be ensured in the complete system.

R35i rotary encoders

Incremental rotary encoders

- Synchro flange (resolver size 15)
- Hollow through shaft
- Self-centering, without integral bearing



Housing with central hole (HR)

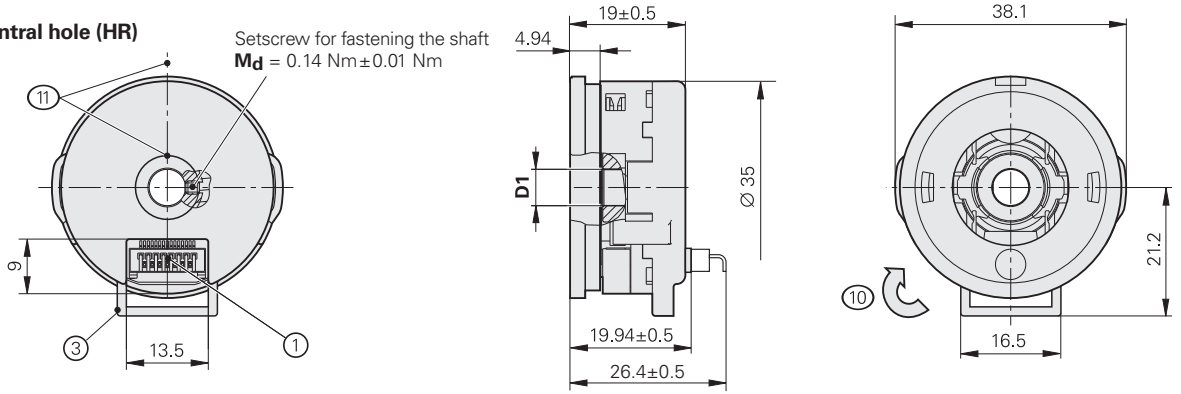

Closed housing (CR)

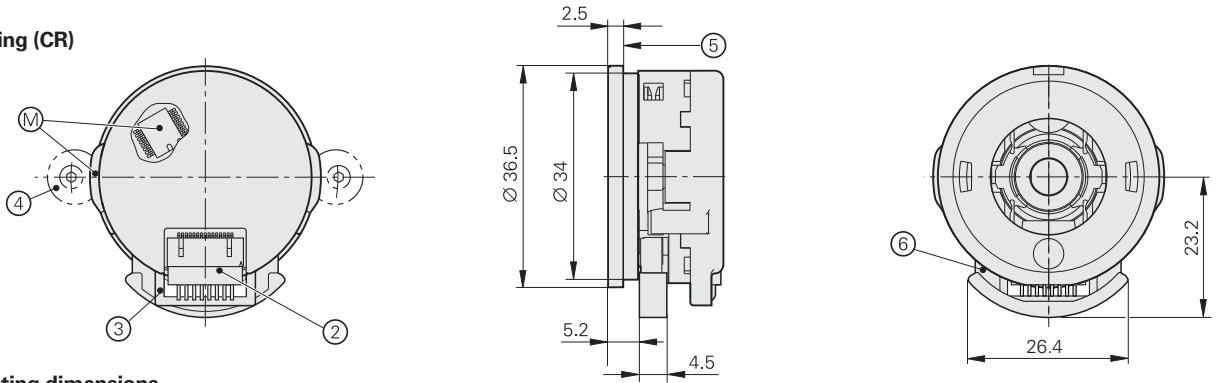

Required mating dimensions

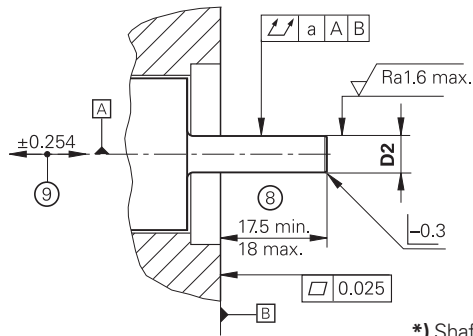
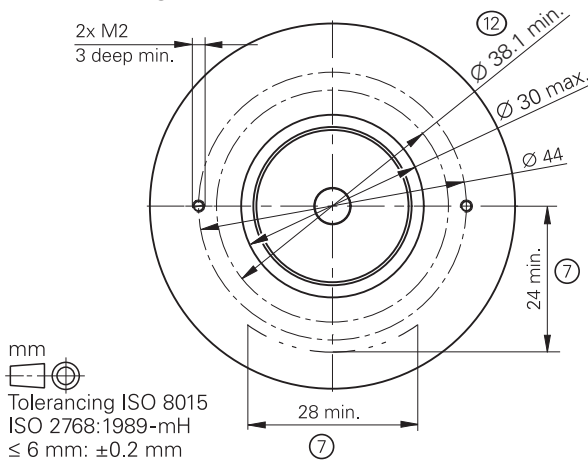

Signal periods	\sqrt{a}
≤5000	0.05
>5000	0.03
≤10000	0.03

*) Shaft diameter in inches and mm

- ▣ = Bearing of mating shaft
- M = Measuring point for operating temperature
- 1 = 15-pin axial header
- 2 = 15-pin radial header
- 3 = Housing with strain relief (SHR/SCR)
- 4 = Proposed fastening with fixing clamp (ID 200032-02) and screw (ISO 4762 – M2); 2x 180° or 3x 120°; tightening torque: 0.21 Nm ±0.03 Nm
- 5 = Clamping surface
- 6 = Slide lock in mounting position
- 7 = Required installation space for slide lock in mounting position
- 8 = Max. dimension for closed housing (CR/SCR)
- 9 = Maximum permissible motion between shaft and stator (including thermal expansion); dynamic axial motion is permitted over the entire value
- 10 = Direction of shaft rotation for ascending position values
- 11 = Reference mark position ±10°
- 12 = Flange surface; ensure full-surface contact in the area around the holes for the screws

Setscrew socket	*)	D1 +0.01 0	D2 0 -0.013
SW 0.89 Hex	3/8+	Ø 9.528	Ø 9.525
	3/8	Ø 9.520	Ø 9.517
0.048" Bristol 4-Spine	8 mm	Ø 8	Ø 7.997
	5/16+	Ø 7.940	Ø 7.937
	5/16	Ø 7.932	Ø 7.929
	1/4+	Ø 6.353	Ø 6.350
	1/4	Ø 6.345	Ø 6.342
	6 mm	Ø 6	Ø 5.997
	5 mm	Ø 5	Ø 4.997
	3/16+	Ø 4.765	Ø 4.762
	3/16	Ø 4.757	Ø 4.754
	4 mm	Ø 4	Ø 3.997
	1/8+	Ø 3.178	Ø 3.175
	1/8	Ø 3.170	Ø 3.167
	3 mm	Ø 3	Ø 2.997

R35i					
Interface*	LD/0	PP/0	LD/LD	LD/PP	PP/PP
Signal periods per rev.*	100, 200, 250, 256, 400, 500, 512, 625, 800, 1000, 1024, 1250, 2000, 2048, 2500, 4000, 4096, 5000, 8000, 8192, 10000 Metal graduation: up to 5000; glass graduation: over 5000				
Reference mark Width / Gate*	One 1 Width: 90° ±45° elec. Gate: U _{a1} High and U _{a2} High 6 Width: 90° ±45° elec. Gate: U _{a1} Low and U _{a2} Low 7 Width: 270° ±45° elec. Gate: U _{a1} High and U _{a2} High 8 Width: 270° ±45° elec. Gate: U _{a1} Low and U _{a2} Low				
Output frequency	≤ 1.83 MHz				
Commutation Signal periods per rev.*	Without 0		Signal tracks U, V, W 2 to 32		
System accuracy ¹⁾	Metal graduation: ±300" Glass graduation: ±150"				
Electrical connection Connection orientation*	15-pin PCB connector R = Radial, A = Axial				
Supply voltage	DC 5 V ±0.5 V				
Current consumption Typically 5 V, without load Max. 5.5 V, without load Max. 5.5 V, with load	≤ 45 mA ≤ 105 mA ≤ 205 mA	≤ 45 mA ≤ 95 mA ≤ 105 mA	≤ 45 mA ≤ 110 mA ≤ 310 mA	≤ 45 mA ≤ 105 mA ≤ 210 mA	≤ 45 mA ≤ 95 mA ≤ 115 mA
Shaft*	Hollow through shaft with radial clamping Shaft diameter: See <i>Mating dimensions</i>				
Mech. permissible speed	Metal graduation: ≤ 30000 rpm Glass graduation: ≤ 12000 rpm				
Moment of inertia of rotor	Metal graduation: 0.2 · 10 ⁻⁶ kgm ² Glass graduation: 0.3 · 10 ⁻⁶ kgm ²				
Permissible motion of measured shaft	Axial: ±0.254 mm Radial runout: 0.05 mm TIR (≤ 5000 signal periods per rev.) 0.03 mm TIR (> 5000 signal periods per rev.)				
Vibration 55 Hz to 2000 Hz Shock: 6 ms	≤ 200 m/s ² (EN 60068-2-6) ≤ 2000 m/s ² (EN 60068-2-27)				
Operating temperature	-30 °C to 115 °C				
Relative humidity	≤ 93% (40 °C/21 d as per EN 60068-2-78), without condensation				
Protection rating EN 60529	IP30 ²⁾				
Mass	≈ 0.03 kg				
ID number	1064590-xx	1282231-xx	1188619-xx	1282244-xx	1282236-xx

* Please select when ordering

¹⁾ Unmounted; additional errors due to mounting of the measured shaft are not considered.

For a measured shaft eccentricity of 1 µm, the measuring error increases by ±16.4"

²⁾ Electromagnetic compatibility must be ensured in the complete system.

R35iL rotary encoders

Incremental rotary encoders

- Ø 32.5 mm flange for axial mounting
- Hollow through shaft
- Self-centering, without integral bearing

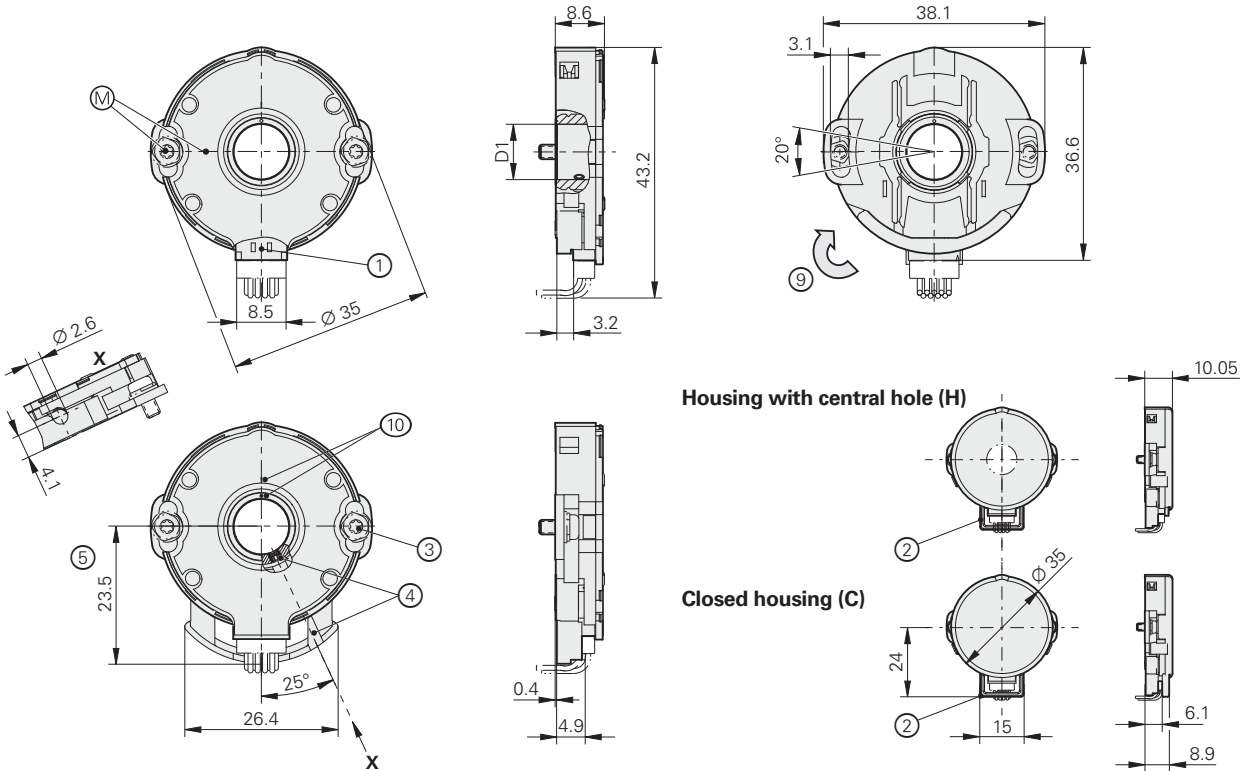

Required mating dimensions

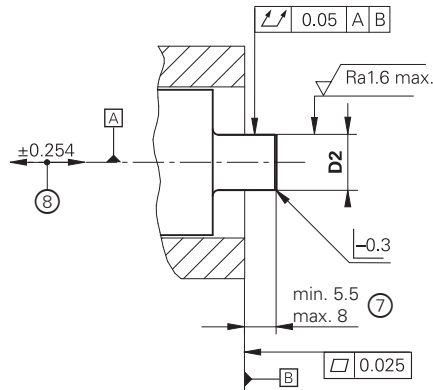
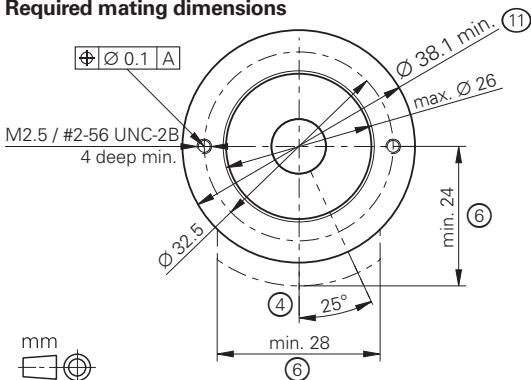

Tolerancing ISO 8015
ISO 2768:1989-mH
≤ 6 mm: ±0.2 mm

- ▣ = Bearing of mating shaft
- M = Measuring point for operating temperature
- 1 = 9-pin radial header
- 2 = Housing with strain relief (SH/SC)
- 3 = Torx T8 fastening screws for flange:
2x M2.5x5.25 (ID 548595-02) or 2x #2-56 UNCx5.25 (ID 548595-03);
tightening torque: 0.21 Nm±0.02 Nm
- 4 = Setscrew; tightening torque: 0.14 Nm ± 0.01 Nm; note installation space for tool
- 5 = Slide lock in mounting position
- 6 = Required installation space for slide lock in mounting position
- 7 = Max. dimension for closed housing (C/SC)
- 8 = Maximum permissible motion between shaft and stator (including thermal expansion);
dynamic axial motion is permitted over the entire value
- 9 = Direction of shaft rotation for ascending position values
- 10 = Reference mark position ±10°
- 11 = Flange surface; ensure full-surface contact in the area around the holes for the screws

*) Shaft diameter in inches and mm

Setscrew socket	*)	D1 +0.01 0	D2 0 -0.013
0.048" Bristol 4-Spine	3/8+	Ø 9.528	Ø 9.525
	3/8	Ø 9.520	Ø 9.517
	8 mm	Ø 8	Ø 7.997
	5/16	Ø 7.932	Ø 7.929
	1/4+	Ø 6.353	Ø 6.350
	1/4	Ø 6.345	Ø 6.342
	6 mm	Ø 6	Ø 5.997
	5 mm	Ø 5	Ø 4.997
	3/16+	Ø 4.765	Ø 4.762
	3/16	Ø 4.757	Ø 4.754
	4 mm	Ø 4	Ø 3.997
	1/8+	Ø 3.178	Ø 3.175
3 mm	Ø 3	Ø 2.997	

R35iL	
Interface*	PP/0 PP/PP
Signal periods per rev.*	100, 200, 250, 256, 400, 500, 512, 625, 800, 1000, 1024, 1250, 2000, 2048, 2500, 4000, 4096, 5000
Reference mark Width / Gate*	One 1 Width: 90° ±45° elec. Gate: U _{a1} High and U _{a2} High 6 Width: 90° ±45° elec. Gate: U _{a1} Low and U _{a2} Low 7 Width: 270° ±45° elec. Gate: U _{a1} High and U _{a2} High 8 Width: 270° ±45° elec. Gate: U _{a1} Low and U _{a2} Low
Output frequency	≤ 1.83 MHz
Commutation Signal periods per rev.*	Without 0 Signal tracks U, V, W 2 to 32
System accuracy ¹⁾	±300"
Electrical connection Connection direction	9-pin PCB connector Radial
Supply voltage*	DC 3.3 V ±0.165 V DC 5 V ±0.5 V
Current consumption Typical, without load Maximum, without load Maximum, with load	DC 3.3 V or 5 V: ≤ 55 mA DC 3.47 V or 5.5 V: ≤ 90 mA DC 3.47 V or 5.5 V: ≤ 105 mA DC 3.3 V or 5 V: ≤ 55 mA DC 3.47 V or 5.5 V: ≤ 90 mA DC 3.47 V or 5.5 V: ≤ 110 mA
Shaft*	Hollow through shaft with radial clamping Shaft diameter: See <i>Mating dimensions</i>
Mech. permissible speed	≤ 30000 rpm
Moment of inertia of rotor	0.2 · 10 ⁻⁶ kgm ²
Permissible motion of measured shaft	Axial: ±0.254 mm Radial runout: 0.05 mm TIR
Vibration 55 Hz to 2000 Hz Shock: 6 ms	≤ 200 m/s ² (EN 60068-2-6) ≤ 2000 m/s ² (EN 60068-2-27)
Operating temperature	-30 °C to 115 °C
Relative humidity	≤ 93% (40 °C/21 d as per EN 60068-2-78), without condensation
Protection ²⁾ EN 60529	Without housing: IP00 With housing: IP30
Mass	≈ 0.03 kg
ID number	1064357-xx (DC 3.3 V) 1086065-xx (DC 5 V) 1046201-xx (DC 3.3 V) 1041174-xx (DC 5 V)

* Please select when ordering

¹⁾ Unmounted; additional errors due to mounting of the measured shaft are not considered.

For a measured shaft eccentricity of 1 µm, the measuring error increases by ±16.4"

²⁾ Electromagnetic compatibility must be ensured in the complete system.

General electrical information

Scope

This general electrical information applies to RENCO rotary encoders and output cables. No fault identification measures have been implemented in RENCO products. The operational safety of the application in conjunction with the encoders must be ensured in the complete system. For any deviating information, see the specifications.

Power supply

Connect RENCO rotary encoders only to downstream electronics whose power comes from PELV systems (for an explanation of terms, see EN 60204-1).

RENCO rotary encoders meet the requirements of the IEC 61010-1 standard if power is supplied from a secondary circuit with limited energy (low voltage, limited energy) as per IEC 61010-1^{3rd Ed.}, Section 9.4, or from a Class 2 secondary circuit as per UL1310.¹⁾

A **stabilized DC voltage U_P** is required for powering the rotary encoder. Information regarding current consumption and voltage is provided in the respective specifications. Regarding the ripple voltage of the DC power, the following parameters apply:

- High-frequency interference
 $U_{PP} < 250 \text{ mV}$ with $dU/dt > 5 \text{ V}/\mu\text{s}$
- Low-frequency fundamental ripple
 $U_{PP} < 100 \text{ mV}$

However, the supply voltage limits must not be violated by the ripple.

The voltage values must be complied with at the rotary encoder. When designing the power supply, use the maximum current consumption in accordance with the *Specifications*.

For the sake of comparison and for inspection purposes, the typical current consumption and power consumption at typical ambient and operating conditions without load (only supply voltage connected) are specified for the typical supply voltage or rated voltage. This information is non-binding and subject to change at any time without notice.

For the power supply range of the rotary encoders, refer to the *specifications*. For **calculating the current consumption and power consumption** of the rotary encoder, take into account the voltage U_P actually applied to the encoder. This voltage consists of the supply voltage U_E provided by the downstream electronics minus the **voltage drop ΔU_1** on the supply wires.

Resistance of the supply wires

The resistance of the supply wires (adapter cable and connecting cable) can be calculated with the following formula:

$$R_L = 2 \cdot \frac{1.05 \cdot L_C}{56 \cdot A_P}$$

The voltage drop ΔU in the supply lines is calculated as follows:

$$\Delta U_1 = 2 \cdot \frac{1.05 \cdot L_C}{56 \cdot A_P} \cdot I_M \cdot 10^{-3}$$

If the value for the voltage drop ΔU_1 is known, then the following values can be calculated as follows:

Voltage at the rotary encoder:
 $U_P = U_E - \Delta U_1$

Current consumption of the rotary encoder:
 $I_M = \frac{\Delta U_1}{R_L}$

Power consumption of the rotary encoder:
 $P_M = U_P \cdot I_M$

Power output of the downstream electronics:
 $P_E = U_E \cdot I_M$

Definitions:

U_P	Voltage at the rotary encoder in V
I_M	Current consumption of the rotary encoder in mA
P_M	Power consumption of the rotary encoder in W
U_E	Supply voltage at the downstream electronics in V
P_E	Power output of the downstream electronics in W
ΔU_1	Voltage drop over the cable in V
L_C	Cable length in m
A_P	Cross section of the supply lines in mm^2 (see Output cables)
2	Factor for complete circuit
1.05	Length factor due to twisted wires
56	Electrical conductivity of copper
R_L	Resistance of the supply wires (for both directions) in ohms

RENCO rotary encoders to the downstream electronics E:

$$U_P = U_E - \Delta U_1$$

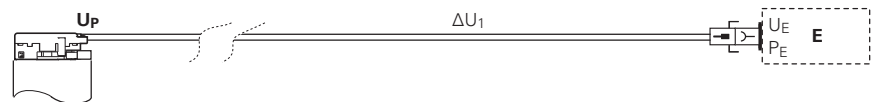

¹⁾In place of IEC 61010-1^{3rd Ed.}, Section 9.4, the corresponding sections of the standards DIN EN 61010-1, EN 61010-1, UL 61010-1 and CAN/CSA-C22.2 No. 61010-1 can be used.

Switch-on/off behavior of the rotary encoders

Valid output signals are available after the switch-on time t_{SOT} . During the time t_{SOT} , the output signals have the maximum voltage values U_{Pmax} (see specifications). If the power supply is switched off, or if the supply voltage falls below U_{Pmin} , then the output signals are invalid as well.

If the rotary encoder is operated using interface electronics, then the switch-on/off conditions of the interface electronics must also be taken into account.

Electrically permissible shaft speed or traversing speed

The maximum permissible speed of a rotary encoder is based on the following factors:

- The mechanically permissible speed (see specifications) and
- the electrically permissible speed

The electrically permissible speed is limited by the following factors:

- The maximum permissible output frequency (see specifications)
- The minimally permissible edge separation for the downstream electronics

Block commutation

The number of signal periods is equivalent to the number of motor pole pairs.

1 pole pair $\hat{=}$ 2 motor poles

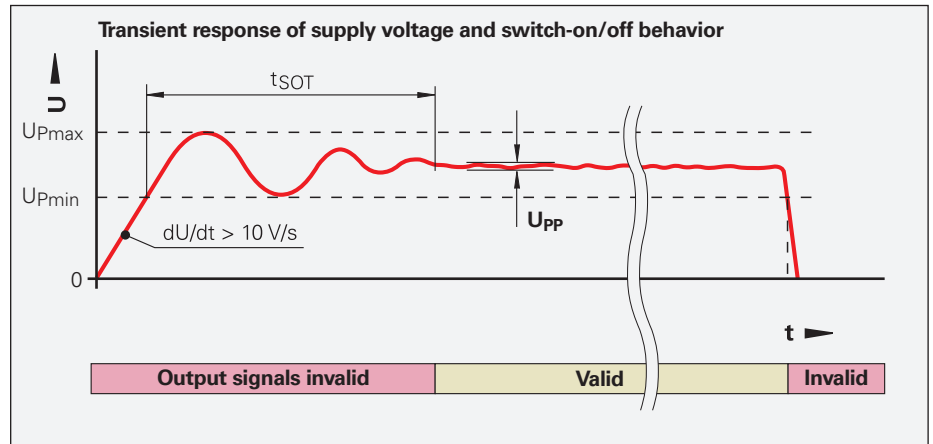

$t_{SOT} =$ Typical: 1.3 ms
Max.: 2.6 ms

Electrical safety

Rotary encoders from RENCO are certified in accordance with IEC 61010-1, UL 61010-1, and CAN/CSA-C22.2 No. 61010-1, and must therefore be supplied from PELV systems (see EN 60204-1 for a definition) with limited power (limited-energy circuit).

The housings of the rotary encoders do not exhibit an electrical connection to internal electrical circuits. Rotary encoders with exposed electronics must be protected from damage and the ingress of foreign matter and liquids by means of a cover.

Resistance to electrostatic charging

The encoders are designed to resist an electrostatic charge of up to 500 V.

Electromagnetic compatibility

Sources of electrical interference

Electrical interference is primarily caused by capacitive or inductive coupling. This coupling can arise over wires and at input and output terminals on devices.

Typical sources of electrical interference include the following:

- Strong magnetic fields from transformers, brakes and electric motors
- Relays, contactors and solenoid valves
- High-frequency equipment, pulse devices and stray magnetic fields from switched-mode power supplies
- Power cables and supply lines to the abovementioned devices

Conformity

If the measures listed below are complied with, then RENCO rotary encoders fulfill

EMC Directive 2014/30/EU with regard to the generic standards for the given area of application:

• Immunity

Specifically, the following basic standards:

- ESD EN 61000-4-2
- Electromagnetic fields EN 61000-4-3
- Burst EN 61000-4-4
- Surge EN 61000-4-5
- Conducted disturbances EN 61000-4-6
- Power frequency magnetic fields EN 61000-4-8
- Voltage dips, short interruptions EN 61000-4-11

• Emission

Measures

The EMC Directive requires the attainment of interference-free operation without the need for EMC expertise. The following measures serve to ensure this level of interference-free operation (please consult with HEIDENHAIN as needed):

- Properly install or mount rotary encoders in accordance with the mounting instructions
- Use only original RENCO cables. Comply with the maximum permissible cable lengths for the respective interface. For usage that deviates from standard usage (assignment of signals and connectors), the manufacturer of the complete system must ensure conformity.
- Do not install cables in the direct vicinity of sources of interference (inductive consumers such as contactors, motors, frequency inverters, solenoid valves, etc.):
 - Sufficient decoupling from interference-signal-conducting cables can usually be achieved by an air clearance of 100 mm or, when cables are routed in metal ducts, by a grounded partition
 - A minimum clearance of 200 mm from storage reactors in switching power supplies is required
- Prevent accidental contact between the shield (e.g., connector) and other metal parts.
- Use connecting elements (e.g., connectors or terminal boxes) with metal housings. Only the signals and power supply of the connected encoder may be routed through these elements

- Connect the electrically conductive housing, connecting elements and downstream electronics with each other by means of the cable shield. Connect the shield over a large area along the complete circumference (360°).
- Install rotary encoders with exposed electronics or a plastic housing in a closed metal housing. If other signals and sources of interference will pass through the housing, then EMC expertise is required for interference-free operation, and the manufacturer of the complete system must ensure conformity.
- Connect the (external) shield with functional earth in accordance with the mounting instructions.
- For devices and cable assemblies with plastic connectors or connectors without a large-area shield connection, connect the (external) shield with functional earth over a large area just a short distance ahead of the connector (shield clamp; see figure). There must be no source of interference in the immediate vicinity.
- If compensating currents are to be expected within the complete system, then a separate equipotential bonding conductor must be provided. The shield is not meant to serve as an equipotential bonding conductor.
- Use high-frequency impedance grounding for rotary encoders (see EN 60204-1, Chapter EMC)

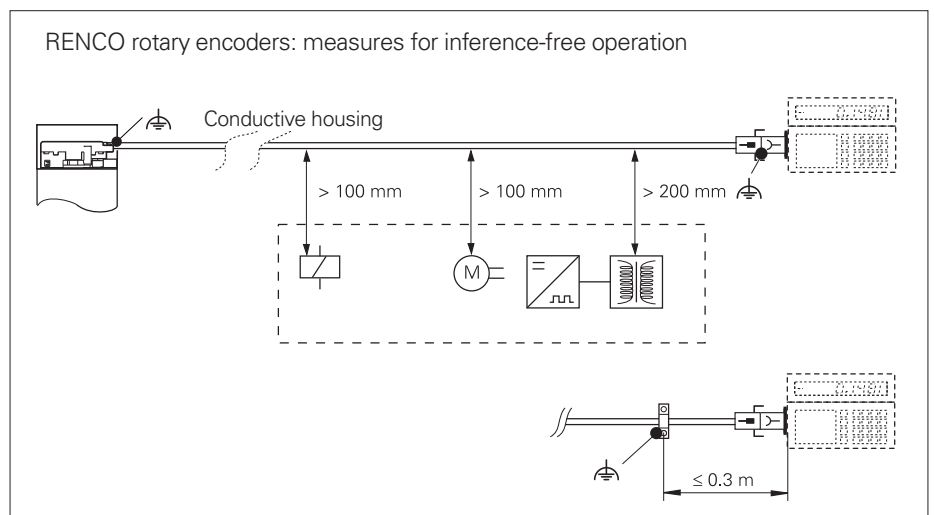

LD square-wave signals

For incremental and commutation signals with differential line driver as per EIA standard RS-422.

Incremental signals	Two square-wave signals $\overline{U_{a1}}, U_{a2}$ with 90° elec. phase shift and their inverted signals $\overline{U_{a1}}, \overline{U_{a2}}$
Reference mark signal Pulse width	One square-wave pulse U_{a0} and its inverted pulse $\overline{U_{a0}}$ 90° elec. or 270° elec. For information about the ordering key, see the <i>R35i Selection Guide</i> or the specifications
Commutation signals	Three square-wave signals U, V, W and their inverse signals $\overline{U}, \overline{V}, \overline{W}$
Signal amplitude	Differential line driver as per EIA standard RS-422
Permissible load	$Z_0 \geq 100 \Omega$ Between associated outputs $ I_L \leq 20 \text{ mA}$ Maximum load per output $C_{load} \leq 1000 \text{ pF}$ To 0 V Outputs are protected against a short to 0 V
Switching times (10% to 90%)	$t_r / t_f \leq 30 \text{ ns}$ (typically 10 ns) With 1 m cable and recommended input circuitry

$U_{a1}, \overline{U_{a1}}, U_{a2}, \overline{U_{a2}}$

On-off ratio

$X1+X2 = 0.5T \pm 0.2T$
 $X2+X3 = 0.5T \pm 0.2T$

Phase angle

$0.375T \geq Xn \geq 0.125T$
(n = 1, 2, 3, 4)

$U_{a0}, \overline{U_{a0}}$

Pulse width and position

1: $TM = 0.25T \pm 0.125T$

6: $TM = 0.25T \pm 0.125T$

7: $TM = 0.75T \pm 0.125T$

8: $TM = 0.75T \pm 0.125T$

$U, \overline{U}, V, \overline{V}, W, \overline{W}$

On-off ratio

$Rm = (360^\circ \text{ mech.} / \text{number of signal periods}) \pm 2^\circ \text{ mech.}$

Phase angle

$Yn = Rm / 6 \pm 0.3^\circ \text{ mech.}$

Position

Rising edge of the U signal relative to the middle of the reference mark signal U_{a0} (only in the factory default setting). This does not apply after the programming of a new position.

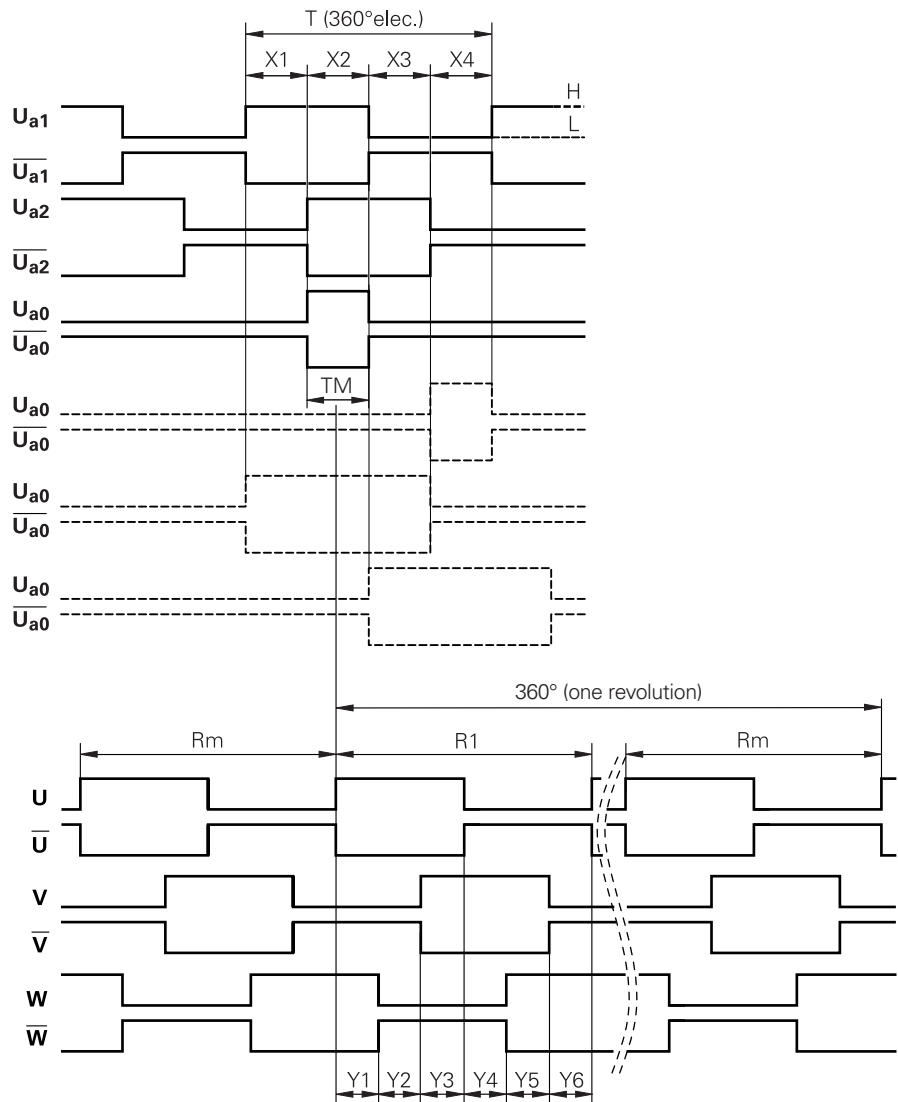

Input circuit design of the downstream electronics

For incremental, reference-mark and commutation signals

Dimensioning

IC_1 = Recommended differential line receiver DS 26 C 32 AT

Z_0 = 120 Ω

C_1 = 220 pF (serves to improve noise immunity)

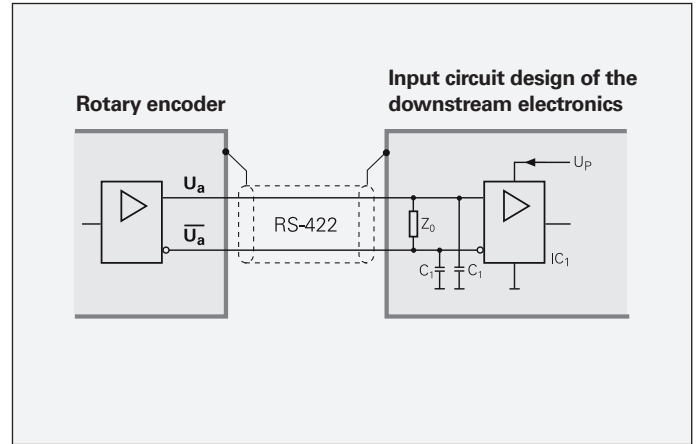

R35i pin layout

15-pin PCB connector															
	Power supply		Incremental signals				Reference mark signal		Commutation signals						
15	13	14	1	2	3	4	5	6	7	8	9	10	11	12	
LD/0	U_P	0V	U_{a1}	\overline{U}_{a1}	U_{a2}	\overline{U}_{a2}	U_{a0}	\overline{U}_{a0}	-	-	-	-	-	-	
LD/LD	U_P	0V	U_{a1}	\overline{U}_{a1}	U_{a2}	\overline{U}_{a2}	U_{a0}	\overline{U}_{a0}	U	\overline{U}	V	\overline{V}	W	\overline{W}	
LD/PP	U_P	0V	U_{a1}	\overline{U}_{a1}	U_{a2}	\overline{U}_{a2}	U_{a0}	\overline{U}_{a0}	U	-	V	-	W	-	

Vacant pins or wires must not be used!

PP square-wave signals

For incremental and commutation signals with a push-pull driver output.

Incremental signals	Two square-wave signals U_{a1} , U_{a2} with 90° elec. phase shift
Reference mark signal Pulse width	One square-wave pulse U_{a0} 90° elec. or 270° elec. For information about the ordering key, see the <i>R35iL Selection Guide</i> and the specifications
Commutation signals	Three square-wave signals U, V, W
Signal amplitude	Voltage supply +5 V: $U_H > 2.5 \text{ V}$ at $-I_H = 4 \text{ mA}$ $U_L < 0.5 \text{ V}$ at $I_L = 4 \text{ mA}$
Permissible load	$ I_L \leq 4 \text{ mA}$ maximal load per output Outputs are not short-circuit proof
Switching times (10% to 90%)	$t_r / t_f \leq 30 \text{ ns}$ With stated input circuit (without cable)

U_{a1} , U_{a2}

On-off ratio

$X1 + X2 = 0.5T \pm 0.2T$

$X2 + X3 = 0.5T \pm 0.2T$

Phase angle

$0.375T \geq X_n \geq 0.125T$

($n = 1, 2, 3, 4$)

U_{a0}

Pulse width and position

1: $TM = 0.25T \pm 0.125T$

6: $TM = 0.25T \pm 0.125T$

7: $TM = 0.75T \pm 0.125T$

8: $TM = 0.75T \pm 0.125T$

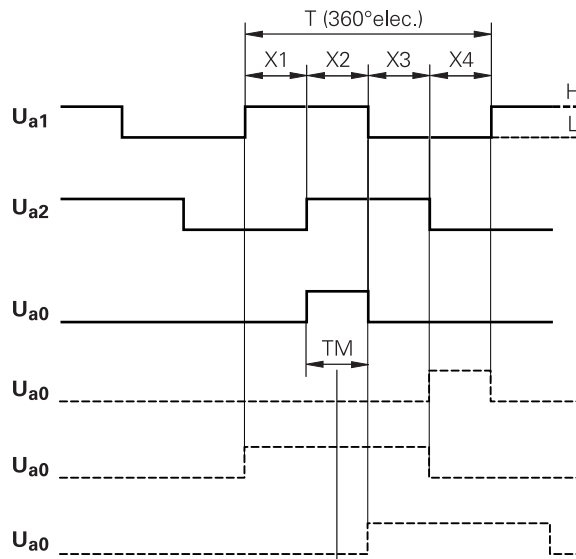

U, V, W

On-off ratio

$R_m = (360^\circ \text{ mech.} / \text{number of signal periods}) \pm 2^\circ \text{ mech.}$

Phase angle

$Y_n = R_m / 6 \pm 0.3^\circ \text{ mech.}$

Position

Rising edge of the U signal relative to the middle of the reference mark signal U_{a0} (only in the factory default setting). This does not apply after the programming of a new position.

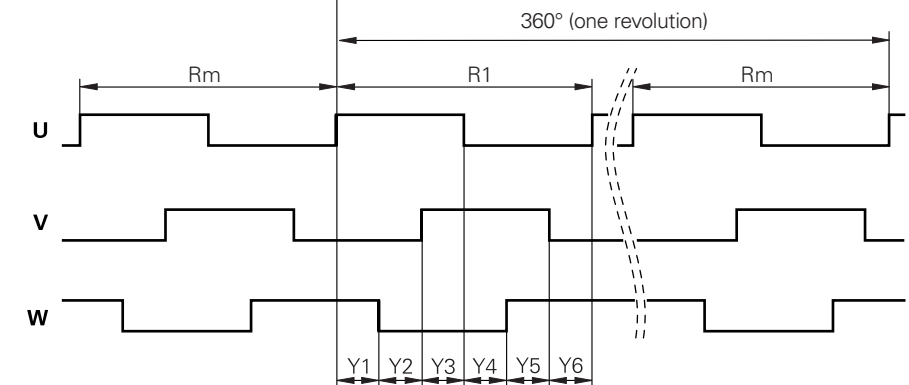

Input circuit design of the downstream electronics

For incremental, reference-mark and commutation signals

Dimensioning

$IC_1 = 74HC14$ CMOS

$R_1 = 1\text{ k}\Omega$

$C_1 = 47\text{ pF}$ (signals U_{a1} , U_{a2} , U_{a0})

$C_1 = 470\text{ pF}$ (signals U, V, W)

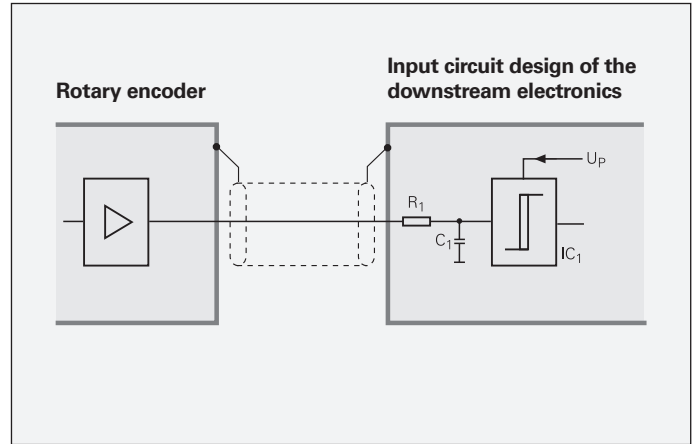

R35i pin layout

15-pin PCB connector														
	Supply voltage		Incremental signals				Reference mark signal		Commutation signals					
	13	14	1	2	3	4	5	6	7	8	9	10	11	12
PP/0	U_P	0V	U_{a1}	-	U_{a2}	-	U_{a0}	-	-	-	-	-	-	-
PP/PP	U_P	0V	U_{a1}	-	U_{a2}	-	U_{a0}	-	U	-	V	-	W	-

Vacant pins or wires must not be used!

R35iL pin layout

9-pin PCB connector								
Interface	Supply voltage		Incremental signals		Reference mark signal	Commutation signals		
	7	8	1	2	3	4	5	6
PP/0	U_P	0V	U_{a1}	U_{a2}	U_{a0}	-	-	-
PP/PP	U_P	0V	U_{a1}	U_{a2}	U_{a0}	U	V	W

Vacant pins or wires must not be used!

Output cables

R35i rotary encoder

Output cables with 15-pin connector (female), braided shield with flexible filler lead, and unstripped cable end							
<p>Without shield connection</p>		<p>With shield connection (cable clamp for shield connection is included)</p>					
Commutation signal	Without commutation signals			With commutation signals			
Interface	PP/0	LD/0	PP/PP	LD/PP	LD/LD		
Output cables without shield connection							
Cable length L 0.5 m	1231728-N5	1231685-N5	1231767-N5	1231760-N5	1231752-N5		
1.0 m	1231728-01	1231685-01	1231767-01	1231760-01	1231752-01		
Output cables with shield connection							
Cable length L 1.0 m	1233223-01	1273065-01	1273064-01	1235360-01	1273058-01		
Pin	Signal	Wire colors					
1	U_{a1}	Yellow	Yellow	Yellow	Yellow	Yellow	
2	U_{a1}	–	White/Yellow	–	White/Yellow	White/Yellow	
3	U_{a2}	Blue	Blue	Blue	Blue	Blue	
4	U_{a2}	–	White/Blue	–	White/Blue	White/Blue	
5	U_{a0}	Orange	Orange	Orange	Orange	Orange	
6	U_{a0}	–	White/Orange	–	White/Orange	White/Orange	
7	U	–	–	Green	Green	Green	
8	\bar{U}	–	–	–	–	White/Green	
9	V	–	–	Brown	Brown	Brown	
10	\bar{V}	–	–	–	–	White/Brown	
11	W	–	–	White	White	White	
12	\bar{W}	–	–	–	–	White/Gray	
13	U_P	Red	Red	Red	Red	Red	
14	0 V	Black	Black	Black	Black	Black	
15	Vacant	–	–	–	–	–	
		PUR cable \varnothing 4.5 mm \pm 0.2 mm 4 x (2 x 0.09 mm ²) (AWG28 7/36) twisted pair Individual-wire insulation: TPE \varnothing 0.6 mm Bend radius Rigid configuration: \geq 14 mm Frequent flexing: \geq 36 mm Temperature range PUR cable jacket: ¹⁾ –40 °C to 100 °C TPE wires: –40 °C to 120 °C			PUR cables \varnothing 6.0 mm \pm 0.2 mm 8 x (2 x 0.09 mm ²) (AWG28 7/36) twisted pair Individual-wire insulation: TPE \varnothing 0.6 mm Bend radius Rigid configuration: \geq 18 mm Frequent flexing: \geq 48 mm Temperature range PUR cable jacket: ¹⁾ –40 °C to 100 °C TPE wires: –40 °C to 120 °C		

Vacant pins or wires must not be used.

Avoid torque or tensile stress on the output cable.

Output cables with a cable length > 0.5 m require strain relief.

¹⁾ Limited temperature range: –20 °C (when flexing) or +80 °C (when exposed to media and hydrolysis)

R35iL rotary encoders

Output cables with 9-pin connector (female), braided shield with flexible filler lead, and unstripped cable end		
Commutation signal	Without commutation signals	With commutation signals
Interface	PP/0	PP/PP
Output cables without shield connection Cable length L 0.5 m 1.0 m	1299950-N5 1299950-01	1264602-N5 1264602-01
Output cables with shield connection Cable length L 1.0 m	1299951-01	1273070-01
Pin	Signal	Wire colors
1	U _{a1}	Yellow
2	U _{a2}	Blue
3	U _{a0}	Orange
4	U	–
5	V	–
6	W	–
7	U _P	Red
8	0 V	Black
9	Vacant	–
<p>PUR cables Ø 4.5 mm ±0.2 mm 4 x (2 x 0.09 mm²) (AWG28 7/36) twisted pair Individual-wire insulation: TPE Ø 0.6 mm</p> <p>Bend radius Rigid configuration: ≥ 14 mm Frequent flexing: ≥ 36 mm</p> <p>Temperature range PUR cable jacket:¹⁾ –40 °C to 100 °C TPE wires: –40 °C to 120 °C</p>		

Vacant pins or wires must not be used.

Avoid torque or tensile stress on the output cable.

Output cables with a cable length > 0.5 m require strain relief.

¹⁾ Limited temperature range: –20 °C (when flexing) or +80 °C (when exposed to media and hydrolysis)

General mechanical information

Certification by an NRTL (Nationally Recognized Testing Laboratory)

The R35i and R35iL rotary encoders meet the safety requirements of UL 61010-1:2012/R:2018-11 for the U.S. and of CAN/CSA-C22.2 No. 61010-1:2012/A1:2018-11 for Canada. The flammability of the housing or flange material is equivalent to HB. The NRTL certification of the PUR cable is indicated by the following label: AWM STYLE 20963 80 °C 30 V.

RoHS

HEIDENHAIN has checked the products for hazardous substances in accordance with the RoHS Directive 2011/65/EU.

Acceleration

During operation and mounting, the rotary encoders are subjected to various types of acceleration.

• Vibration

The encoders are qualified on a test stand under the acceleration values stated in the specifications at frequencies of 55 Hz to 2000 Hz in accordance with EN 60068-2-6.

However, if the application or mounting situation causes long-duration resonant vibration, then proper functioning of the encoder may be impaired, or the encoder may even incur damage.

Thorough testing of the complete system is therefore required.

• Shock

The encoders are qualified on a test stand under the acceleration values stated in the specifications and over the exposure times in accordance with EN 60068-2-27 for non-repetitive, semi-sinusoidal shock. **Continuous shock loads** are therefore not covered and **must be tested in the application.**

The **maximum angular acceleration** is 10^5 rad/s^2 (DIN 32878). This is the highest permissible rotational acceleration at which the rotor can be accelerated without damage to the encoder. A sufficient safety factor is to be determined through system tests. For angular accelerations $\geq 10^4 \text{ rad/s}^2$, the use of an adhesive bond on the shaft is recommended (see *Mounting*).

Protection from contact (EN 60529)

After installation of the encoder, all rotating parts must be protected from accidental contact during operation.

Protection rating (EN 60529)

The R35i and R35iL rotary encoders meet their specified protection rating when the cable is connected and the housing is mounted (see the specifications).

Conditions for longer storage times

For storage times of at least 12 months, HEIDENHAIN recommends the following:

- Leave the encoders in the original packaging.
- The storage location should be dry, free of dust, and temperature-regulated, as well as free of vibration, mechanical shock, and chemical influences.

Temperature ranges

For the encoder in its packaging, the applicable storage temperature range is -30 °C to $+65 \text{ °C}$. The operating temperature range specifies the temperature of the rotary encoder that is permissible during operation under actual installation conditions. Proper functioning of the rotary encoder is guaranteed within this range (DIN 32878). The operating temperature is measured at the measuring point (see dimension drawing) and must not be confused with the ambient temperature. The temperature of the rotary encoder is influenced by its installation conditions, the ambient temperature and the encoder's own heat generation.

System tests

The R35i and R35iL rotary encoders are generally integrated as components into the complete system. In such cases, regardless of the encoder's specifications, thorough tests of the complete system are required. The specifications provided in this brochure apply only to the encoder and not to the complete system. Any operation of the encoder outside of the specified range or intended use is at the user's own risk.

Mounting

For the work steps and dimensions to be complied with during mounting, the information in this brochure and the downloadable videos at www.renco.com are applicable.

Modifications to the encoder

Proper functioning of the R35i and R35iL rotary encoders is ensured only when they are not modified. Any modification, even a minor one, can impair the proper functioning, reliability and safety of the encoders, and result in a loss of warranty. This also includes the use of any additional or non-prescribed locking varnishes, lubricants (e.g., for screws), or adhesives. If you are in doubt, we recommend that you consult with HEIDENHAIN in Traunreut, Germany.

Mounting

Mounting and initial setup must be conducted by a qualified specialist in compliance with regional safety regulations. In addition, the machine manufacturer or design engineer must specify any additional information required for final mounting. Do not engage or disengage any connecting element when power is on. The system must be disconnected from power!

Do not allow the rotary encoder and connecting element to come into contact with aggressive media. Do not clean the encoder with organic solvents such as thinners, alcohol, or mineral spirits. Perform disassembly in reverse order under identical mounting conditions (mounting tolerances and temperature). You can also download mounting instructions on the internet at www.renco.com.

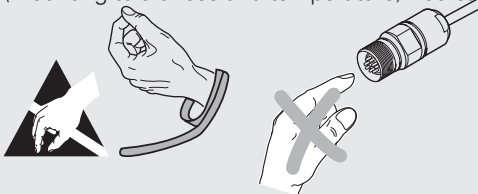

Note the ESD information

Comply with the general electrical and mechanical information.

Mounting the R35i

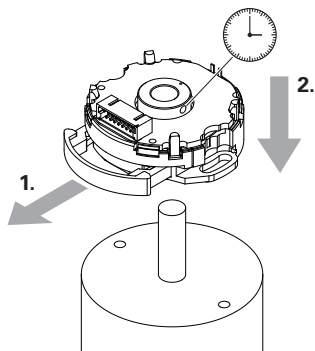

1st step

Ensure that the setscrew for shaft fastening is at 3 o'clock (reference mark position is within the range of $\pm 10^\circ$ mech.) and that the integrated mounting aid (1) is pulled out as far as possible. Slide the encoder (2) onto the motor shaft.

2x
 $M_d = 0.21 \text{ Nm} \pm 0.02 \text{ Nm}$

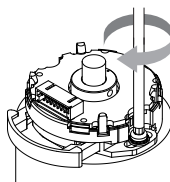

2nd step

Initially tighten the mounting screws finger-tight on both sides. Then tighten them with the required torque.

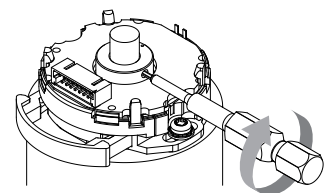

$M_d = 0.14 \text{ Nm} \pm 0.01 \text{ Nm}$

3rd step

Tighten the setscrew with the required torque.

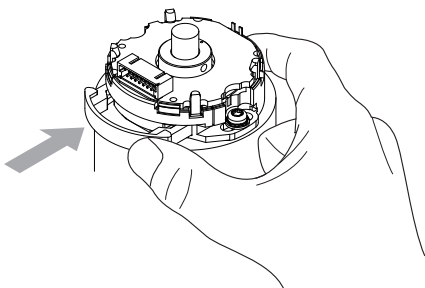

4th step

Push in the built-in mounting aid completely while providing pressure against the other side of the rotary encoder's flange.

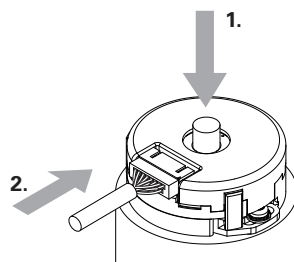

5th step

Mount the encoder housing (1), and connect the output cable (2). Do not engage or disengage any connecting element when power is on.

Mounting the R35iL

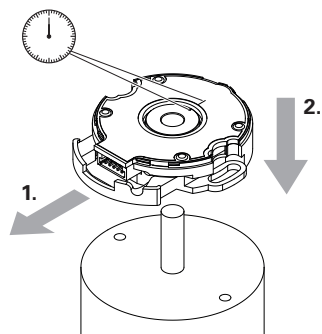

1st step

Ensure that the marking on the rotary encoder shaft (point) is aligned with the marking on the flange (line) (the reference mark position is within $\pm 10^\circ$ mech.) and that the built-in mounting aid (1) is pulled out as far as possible. Slide the encoder (2) onto the motor shaft.

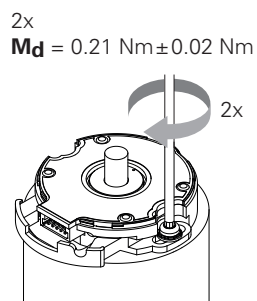

2nd step

Initially tighten the mounting screws finger-tight on both sides. Then tighten them with the required torque.

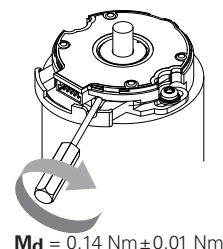

3rd step

Tighten the setscrew with the required torque.

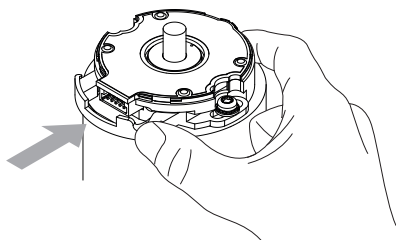

4th step

Push in the built-in mounting aid completely while providing pressure against the other side of the rotary encoder's flange.

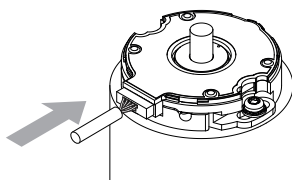

5th step

Connect the output cable. Do not engage or disengage any connecting element when power is on.

Adjustment for motor commutation

You can program the position of the commutation signals U, V, and W using the PWT 101. There are two methods to choose from:

- Static adjustment when the motor is at standstill
- Dynamic adjustment when the motor is rotating

Static adjustment

With the power off, connect the testing cable to the encoder, and supply power to the rotary encoder with the PWT 101. Rotate the motor to the preferred position, and lock the rotor in place. Provide the motor winding with sufficient DC voltage and current. Then tap *Set to static*.

Tapping *Yes* programs the position of the commutation signals U, V, and W at the preferred motor position (rising edge of the U signal).

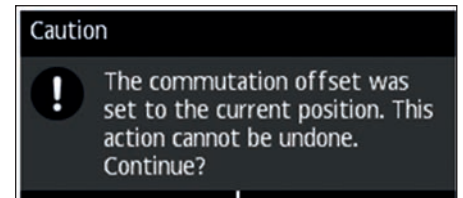
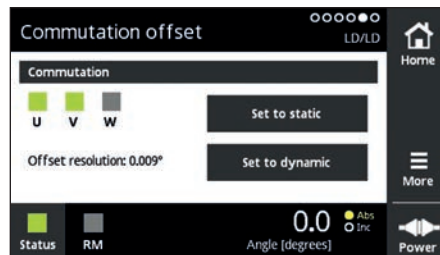

Dynamic adjustment

With the power off, connect the testing cable on the encoder, and supply power to the rotary encoder with the PWT 101 and to the motor. For the direction of shaft rotation for rising position values of the rotary encoder, see the specifications.

Tap *Set to dynamic* in order to measure the offset between the motor EMF and the U signal (U signal applied to the X2 connector of the PWT 101).

Enter the measured offset value into the input field, and confirm with *OK*. Initially, the position of the commutation signals U, V, and W is merely shifted, with further fine adjustment still possible. To perform a further fine adjustment, tap *Change*, and enter a new offset value (repeat until the switching edge of the U signal and of the zero crossover of the motor EMF voltage lie on top of each other). Tapping *Yes* permanently programs the position of the commutation signals.

Please note: Programming can be performed only once! Any further configuration of the motor commutation requires mechanical adjustment (by turning the rotary encoder flange).

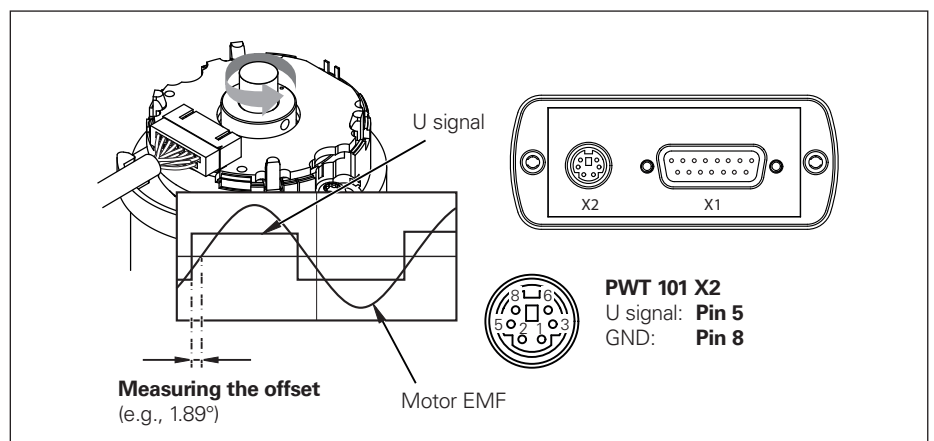
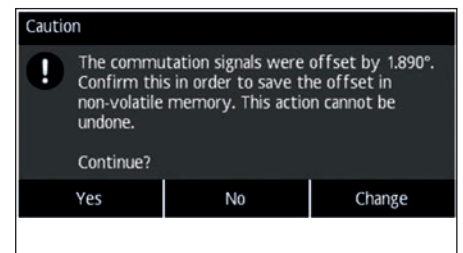
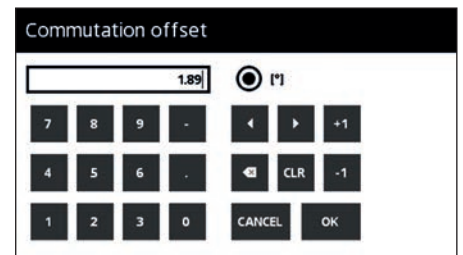

Adhesive bond for shaft coupling

For angular accelerations $\geq 10^4 \text{ rad/s}^2$, HEIDENHAIN recommends the use of an adhesive bond on the shaft.

Proceed as follows:

- Remove any oil, grease or other contaminants on the shaft.
- Apply Loctite Primer T to the motor shaft.
- Mount the rotary encoder in accordance with the instructions. In the case of an R35i, do not mount the housing at this time.
- Apply a small amount of Loctite 290 to the gap between the encoder shaft and the motor shaft on the side opposite of the setscrew. Remove any excess adhesive.
- If you use Loctite 290 adhesive together with Primer T, a hardness of approx. 25 % will be reached within 15 minutes. Final hardness is reached within one hour. For more information on the application and hardening of the adhesive, visit the manufacturer's website: <http://tds.loctite.com/tds5/docs/290-EN.pdf>
- R35i: Mount the encoder housing, and connect the output cable.

How to loosen an adhesive bond for the shaft connection:

- R35i: Remove the encoder housing.
- Apply the Debonder Cleanup Agent X / 8, P / N 06100 from Pacer Technology to the adhesive seam between the motor and the encoder shaft. Allow the debonding agent to penetrate the Loctite adhesive bond for roughly 30 to 40 minutes.
- To remove the encoder, follow the mounting steps in reverse.
- Remove any excess debonding agent and adhesive from the motor shaft and encoder shaft.
- Electrical testing of the rotary encoder by means of the testing and measuring equipment is recommended in order to exclude potential damage.

Mounting accessories

Check the torque setting and the level of bit wear on a regular basis.

Screwdriver

When using screwdrivers with adjustable torque, ensure that they comply with DIN EN ISO 6789 and thus meet the required torque tolerances.

Adjustable torque
0.02 Nm to 0.3 Nm
ID 350379-10



Screwdriver bit (4-spline)

For shaft fastening

R35iL: For all shaft diameters
R35i: For the following shaft diameters:
4 mm, 5 mm, 6 mm, 8 mm
1/8, 1/8+, 3/16, 3/16+, 1/4, 1/4+,
5/16, 5/16+ inch



The screwdriver bit set contains the following parts:

- 1/4-inch adapter with 4-spline (0.048) bit from Bristol Wrench Co.
- Wrench for changing the bits
- Ten "4-spline" replacement bits (0.048)

ID 825869-01

Screwdriver bit hexagonal, width A/F 0.89 mm

For R35i shaft clamping with the following shaft diameters: 3/8 or 3/8+ inch
ID 756768-43



Torx T8 screwdriver bit

For flange-fastening screws of the R35i (Ø 32.5 mm) and R35iL
ID 350378-11

Screwdriver bit hexagonal, width A/F 3/32 inch

For flange fastening screws of the R35i (Ø 46.03 mm)
ID 756768-48

For replacement setscrews for shaft clamping, please consult your sales agency.

Testing equipment and diagnostics

PWT 101

The PWT 101 is a testing device for the functional testing and mounting inspection of RENCO R35i and R35iL rotary encoders.



Block commutation

This module lets you perform the following inspections and settings:

- Mounting inspection
- Output signals
- Signal level
- Counts
- Commutation offset
- Encoder information

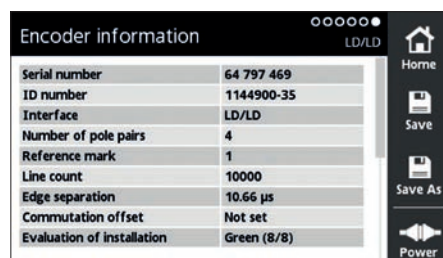
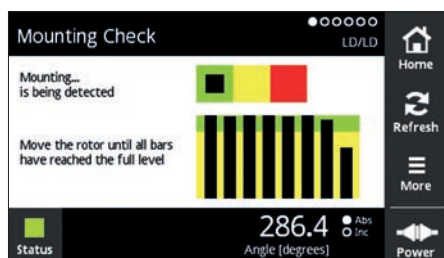

HEIDENHAIN Filebase

The block commutation module and its user's manual can be downloaded at www.heidenhain.com ▶ *Service & Support* ▶ *Downloads* ▶ *Software* ▶ *Inspection and testing devices*.



Further information:

For more information, please refer to the *PWT 101 Block Commutation Module User's Manual*

Miscellaneous testing accessories

Testing cable for the R35i/R35iL rotary encoders

Comes with three 15-pin adapter cables for the R35i, and three 9-pin adapter cables for the R35iL.

ID 1314747-01



Replacement cables

Three 15-pin adapter cables: ID 1314702-01

Three 9-pin adapter cables: ID 1314702-02



Mounting tool

For connecting and disconnecting the cable assembly

ID 1075573-01



To avoid damage to the cable, the pulling force must be applied only to the connector, not to the wires.





HEIDENHAIN

DR. JOHANNES HEIDENHAIN GmbH
Dr.-Johannes-Heidenhain-Straße 5
83301 Traunreut, Germany
☎ +49 8669 31-0
☎ +49 8669 32-5061
info@heidenhain.de

www.heidenhain.com

1319497-22 · 03/2026 · H · Printed in Germany



HEIDENHAIN
worldwide