

Ansicht mit Spannpratzen und Kabeln/Druckluftleitungen
View with fixing clamps, cables, and compressed-air tubes

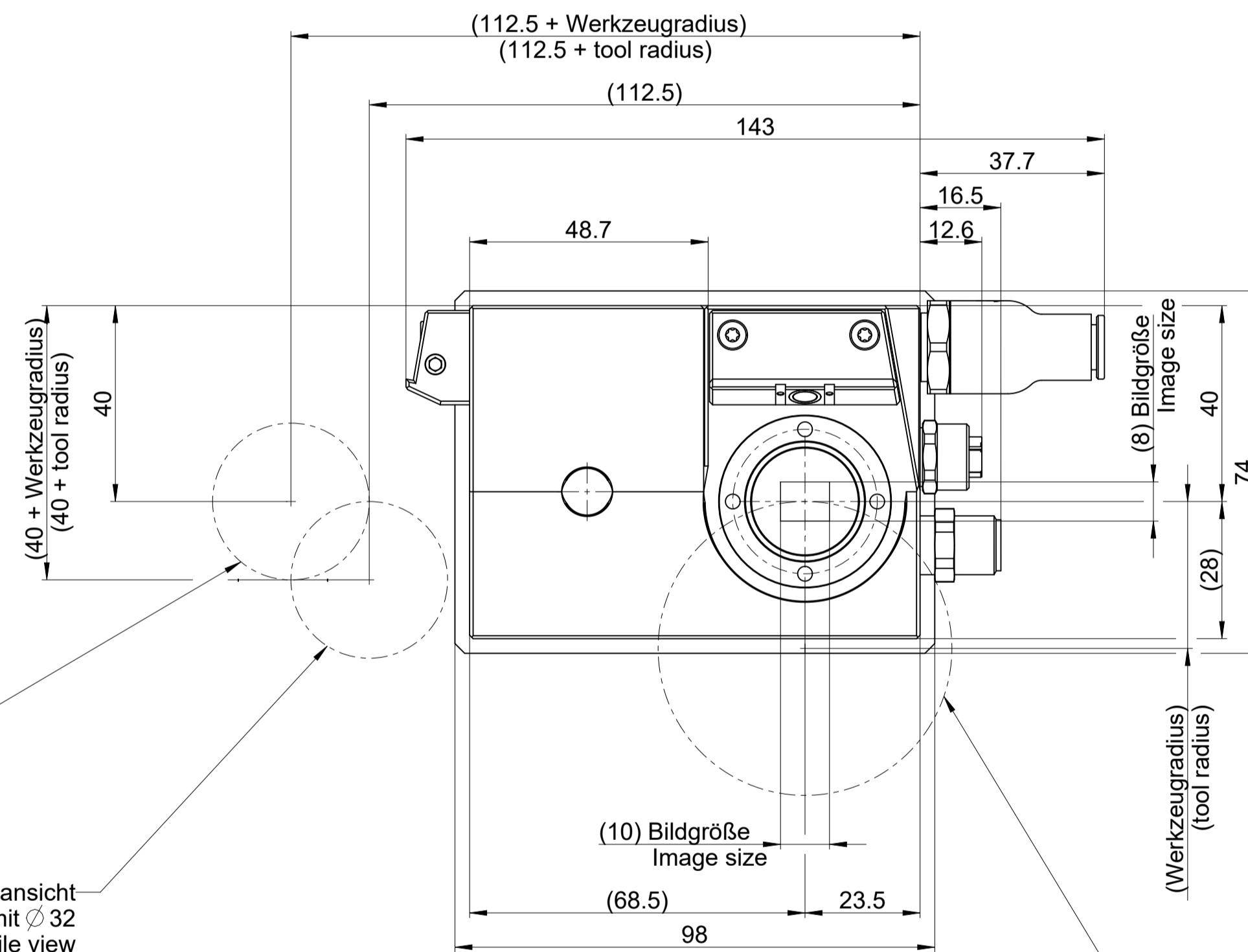
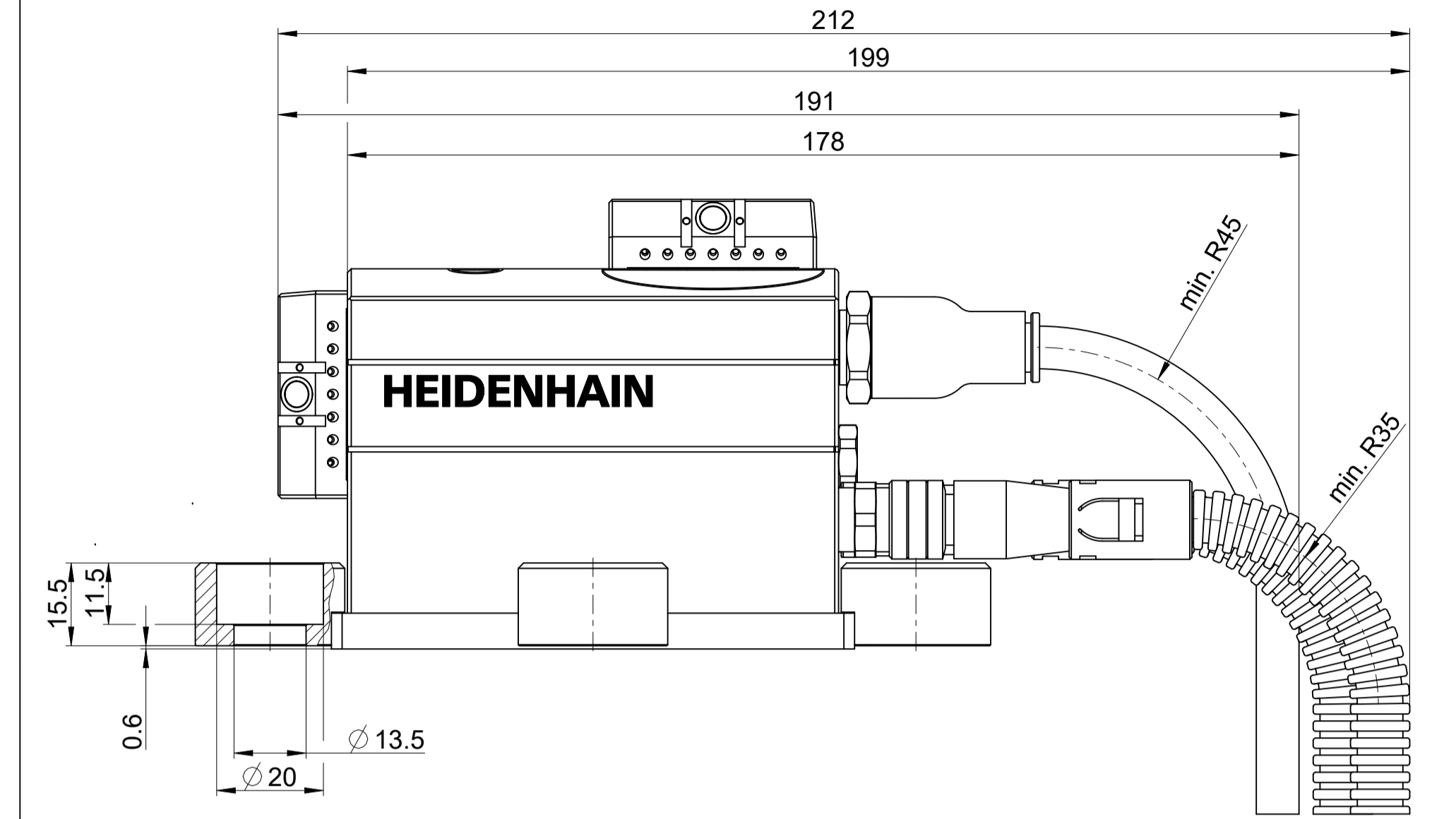

Werkzeugposition für Bildaufnahme
für ein Werkzeug mit $\varnothing 32$
Tool position for image acquisition
shown for a tool with $\varnothing 32$

Werkzeugposition für Profilsicht
für ein Werkzeug mit $\varnothing 32$
Tool position for profile view
shown for a tool with $\varnothing 32$

Werkzeugposition für Schneidenwinkel Vermessung
für ein Werkzeug mit $\varnothing 60$
Tool position for measuring cutting edge angles
shown for a tool with $\varnothing 60$

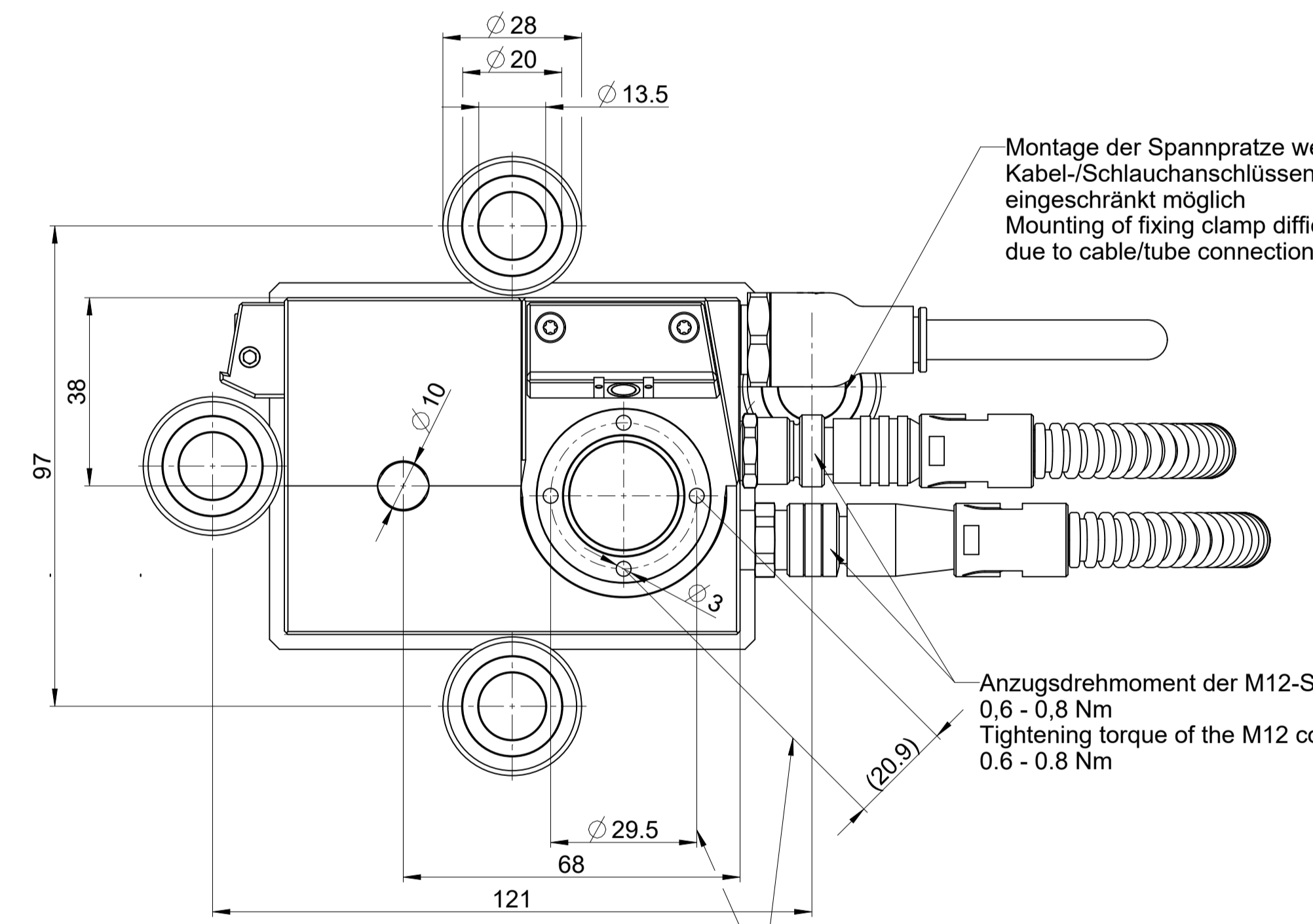

Ansicht mit Schutzkappen
View with protective caps

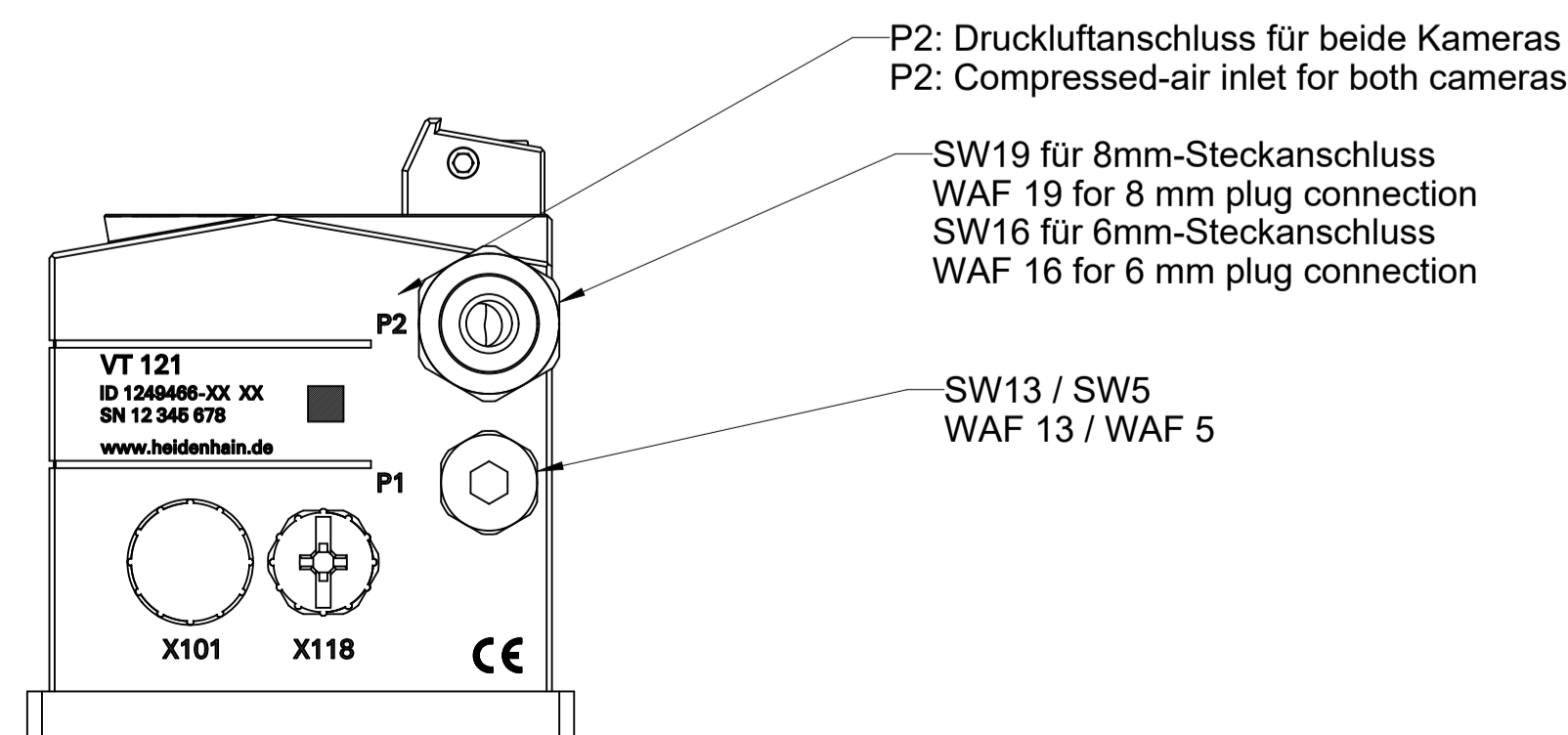

Austausch des Deckglases mit einem handelsüblichen, verstellbaren Stirnlochschlüssel mit 3mm-Stiften
Einschrauben bis auf Anschlag
Ersatzteilnummer: 1321963-01
Replacement of cover glass with a commercially available, adjustable face spanner with 3 mm pins
Screw in as far as it will go
Spare part number: 1321963-01

Original drawing		VT 121		ID number:	C189676-05
Scale		VT 121		Change No.	
Format		Anschlussmaße / Mating Dimensions		Phase:	Serie
Dimensions in mm	1:1	A1		Tolerances as per	ISO 8015
				General Tolerances	ISO 2768-1/2001-mH ±0.2
The reproduction, distribution and utilization of this document as well as the communication of its contents to others without express authorization is prohibited. Offenders will be held liable for the payment of damages. All rights reserved in the event of the grant of a patent, utility model or design. (ISO 15015)					
Released		Version / Revision / Sheet		Page	
22.09.2025		D1294069-03 - A-01		1 of 1	
HEIDENHAIN		DR. JOHANNES HEIDENHAIN GmbH		Document number	
83301 Traunreut, Germany					