



RSF Elektronik

www.rsf.at

MSR 15 | MSS 15 INCREMENTAL MODULAR ANGLE ENCODERS





SPECIAL FEATURES

- Online signal stabilization
- Display of the signal quality directly at the scanning head via 3-coloured LED function
- Permanent control of the signals over the whole measuring range
- High quality of the signals due to singlefield scanning

TERM EXPLANATIONS

Grating period

A grating is a continuous series of lines and spaces printed on the graduation carrier. The width of one line and one space is called the period of the grating. The lines and spaces are accurately placed on the scale.

Signal period

When scanning the grating, the scanning head produces sinusoidal signals with a period equal to the grating period.

Interpolation

The sinusoidal signal period can be electronically divided into equal parts. The interpolation circuitry generates a square-wave edge for each division.

Measuring step

The smallest digital counting step produced by an encoder.

Reference pulse (reference mark)

There is an additional track of marks printed next to the grating to allow a user to find an absolute position along the length of the scale. A one increment wide signal is generated when the encoder head passes the reference mark on the graduation carrier.

This is called a "true" reference mark since it is repeatable in both directions. Subsequent electronics use this pulse to assign a preset value to the absolute reference mark position.

Line rates

Number of the grating periods per rotation.

Error signal (\bar{US})

This signal appears when a malfunctioning encoder generates faulty scanning signals.

Online signal stabilization

During moving the amplitude, offset-error, amplitude differences and phase shift error are measured and stabilized cyclically.

Yaw angle, pitch angle, roll angle, displacement, gap tolerance

Mounting tolerances of the scanning head relative to the scale.

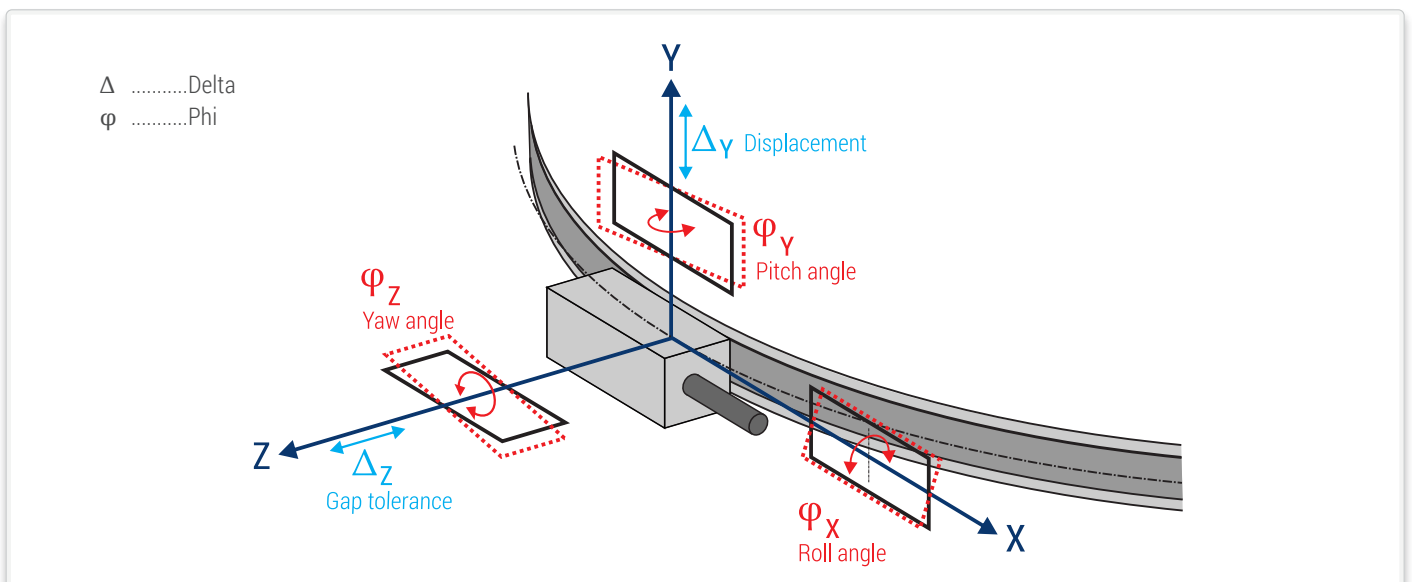

REQUIREMENTS ON AN INCREMENTAL MODULAR ANGLE ENCODER

- CONTAMINATION RESISTANCE
- IMMUNITY AGAINST AGING AND TEMPERATURE CHANGES
- HIGH PERMISSIBLE ROTATIONAL SPEED (MSR 15)
- EASY MOUNTING
- SMALL DIMENSIONS
- NO MECHANICAL BACKLASH; NO FRICTIONAL FORCE
- REFERENCE MARK REPEATABLE
FROM BOTH TRAVERSING DIRECTIONS



MSR 15 AND MSS 15 MEET ALL THESE REQUIREMENTS!

SCANNING PRINCIPLE

The MSR 15 and MSS 15 incremental modular angle encoders work with the imaging, photoelectric measuring principle and a **singlefield reflective scanning method**.

The regulated light of an infrared LED is collimated by a condenser lens and passes through the grid of the reticle. After being reflected from the graduation carrier, the infrared LED generates a periodic intensity distribution on the structured sensor.

The sensor generates high quality sinusoidal signals which are highly insensitive to possible contaminations.

The regulation of the LED ensures a constant signal amplitude, guaranteeing stability in the case of temperature fluctuations and long-run operation.

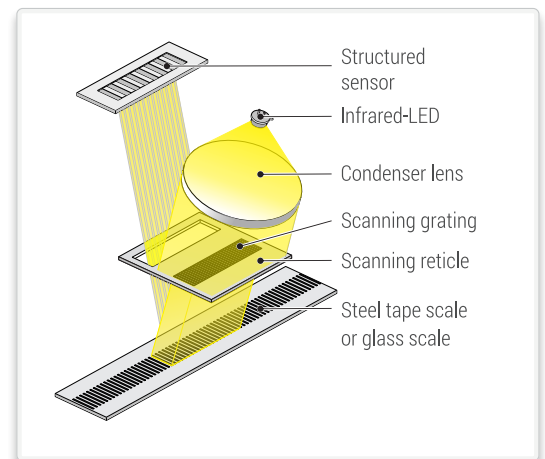

ACCURACY DEFINITION

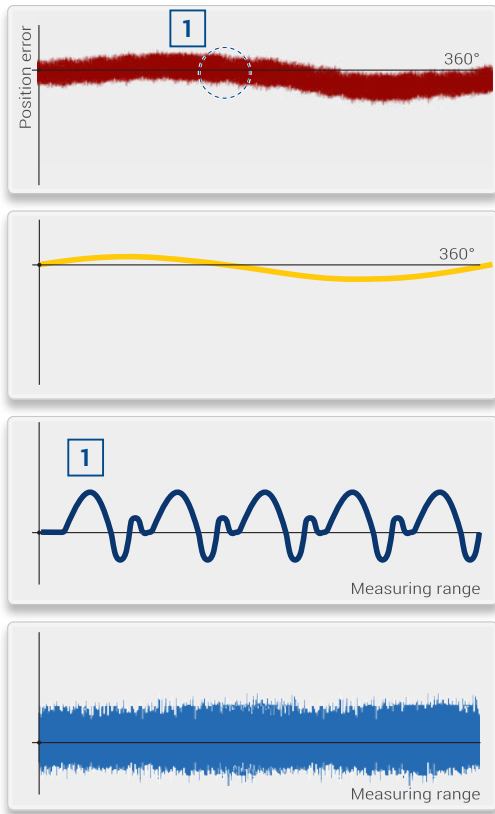

Overall error

=

Baseline error

+

Interpolation error

+

Position noise

The accuracy of an encoder is mainly determined by the baseline error of the scale unit, the interpolation error of the optoelectronic scanning and the position noise.

The baseline error is the error of the scale unit identified in a measurement room under optimum conditions, along a determined measuring length, without any interpolation error and position noise.

With modular angle encoders, an eccentric mounting of the graduation carrier additionally results in a measurement error. In addition, dimensional and form errors of the customer's shaft can result in added eccentricity.

The measuring error results from the following formula:

$$\Delta\varphi = \pm \frac{412 \times e}{D}$$

$\Delta\varphi$ = Measuring error due to eccentricity ["]

e = Resulting eccentricity of the graduation carrier in [μm]
 ■ $0.67 \times \Delta_{\text{max}}$ for drum (TTR) with three-point centering
 ■ $0.5 \times \Delta_{\text{max}} = 1/2$ concentricity for tape scale ring (MBR)

D = Scanning diameter [mm]

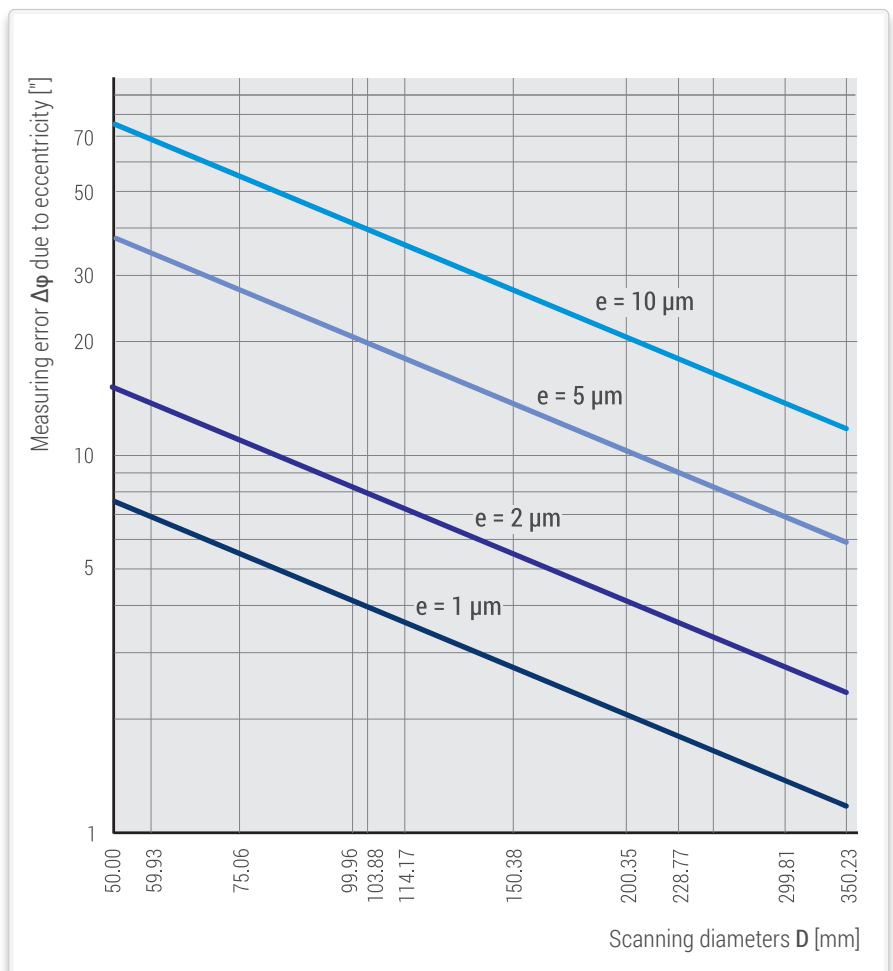

Effect of contamination on the quality and amplitude of scanning signal

Graduation carrier contaminated by fluids, dust, particles, fingerprints etc.

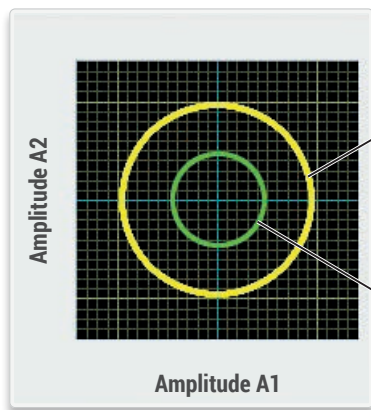

2 Scanning signals without signal stabilization - graduation carrier clean

3 Scanning signals without signal stabilization - graduation carrier contaminated

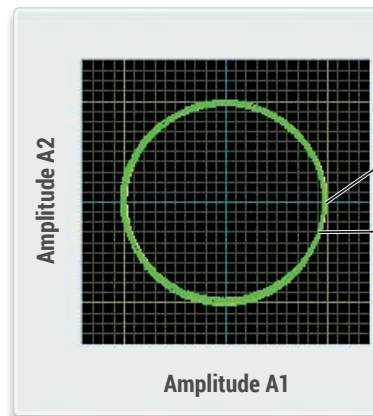

2 Scanning signals with signal stabilization - graduation carrier clean and contaminated

3

Effect of contamination on the interpolation error

Graduation carrier contaminated by fluids, dust, particles, fingerprints etc.

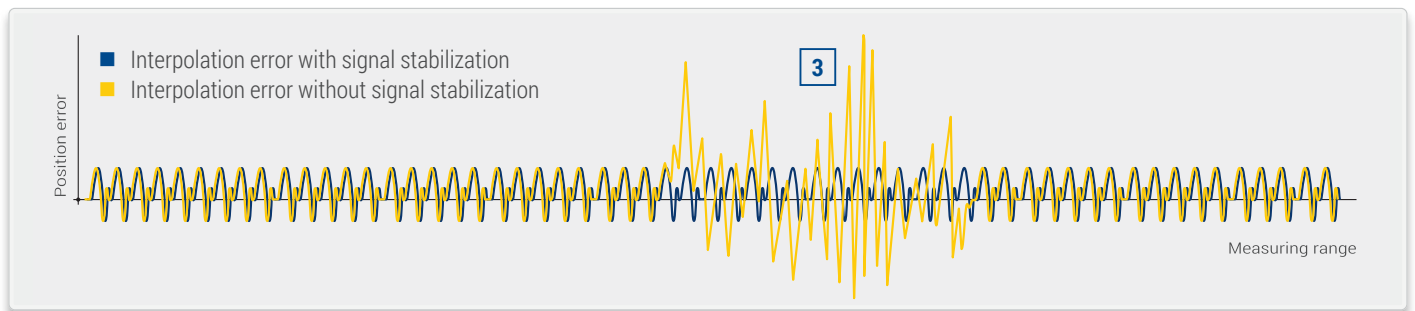

SHIELDING, PIN ASSIGNMENT

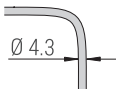

Shielded PUR-cable;
Drag chain qualified.

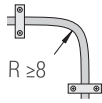

Bending radius fixed mounting



Bending radius continuous flexing

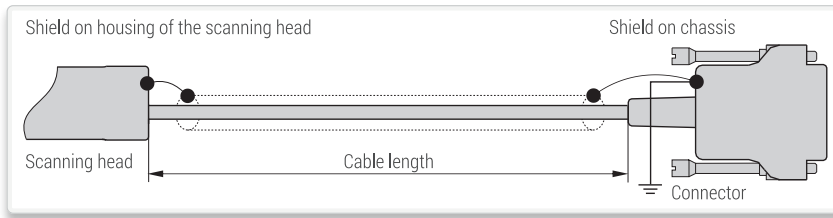

15-pin D-sub

Pin	1	2	3	4	5	6	7	8	9	10	11	12	13	14	15
Sinusoidal voltage signals 1 Vpp	Test**	0 V Sensor	Occupied	RI-	A2-	A1-	V+ Sensor	V+	0 V	nc	nc	RI+	A2+	A1+	nc
Square-wave signals via line driver	Test*	0 V Sensor	US	RI	T2	T1	V+ Sensor	V+	0 V	nc	nc	RI	T2	T1	nc

- * Test = **analog signal switch-over for set-up.**
By applying +5 V to the test pin, the test signals (sinusoidal micro-current signals 11 µApp) are switched to the output connector.
- ** Test = **analog signal switch-over for set-up.**
By applying +5 V to the test pin, the NOT corrected test signals (1 Vpp) are switched to the output connector.
- Sensor: the sensor pins are bridged in the chassis with the particular power supply.
- The shield is connected with the chassis.
- Pins or wires marked "occupied" or "nc" must not be used by the customer.

Pin assignment
(view on pins)

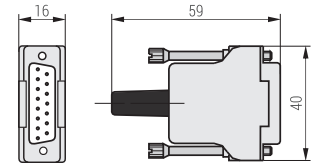
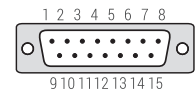

Mass: 28 g

INTERFACES

SINUSOIDAL VOLTAGE SIGNALS 1 V_{pp}

(drawing shows "positive counting direction")

Power supply: +5V ±10 %, max. 160 mA (unloaded)

Track signals (differential voltage A1+ to A1- resp. A2+ to A2-):

Signal amplitude 0.6 V_{pp} to 1.2 V_{pp}; typical 1 V_{pp}

(with terminating impedance Z₀ = 120 Ω between A1+ to A1- resp. A2+ to A2-).

Reference mark (differential voltage RI+ to RI-):

Square-wave pulse with an amplitude of 0.8 up to 1.2 V; typical 1 V

(with terminating impedance Z₀ = 120 Ω between RI+ to RI-)

Advantage:

- High traversing speed with long cable lengths possible.

SQUARE-WAVE SIGNALS

(drawing shows "positive counting direction")

With the integrated interpolation electronics (for times -1, -5, -10, -20, -25, -50, -100 or -200) the photoelement output signals are converted into two square-wave signals that have a phase shift of 90°.

The output signals are „differential“ via line driver (RS 422). One measuring step reflects the measuring distance between two edges of the square-wave signals.

The controls/DRO's must be able to detect each edge of the square-wave signals. The minimum edge separation a_{\min} is listed in the technical data and refers to a measurement at the output of the interpolator (inside the scanning head). Propagation-time differences in the line driver, the cable and the line receiver reduce the edge separation.

Propagation-time differences:

Line driver: max. 10 ns

Cable: 0.2 ns/m

Line receiver: max. 10 ns (referred to the recommended line receiver circuit)

To prevent counting errors, the controls/DRO's must be able to process the resulting edge separation.

Example:

$a_{\min} = 100 \text{ ns}$, 10 m cable

$100 \text{ ns} - 10 \text{ ns} - 10 \times 0.2 \text{ ns} - 10 \text{ ns} = 78 \text{ ns}$

Power supply: +5V ±10%, max. 160 mA (unloaded)

Advantages:

- Noise immune signals.

- No further subdividing electronics necessary.

Voltage signals (1 V_{pp})

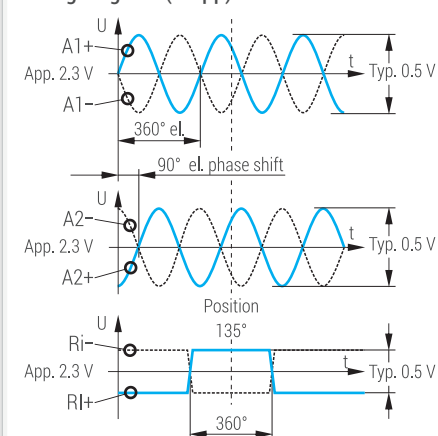

Square-wave signals "differential"

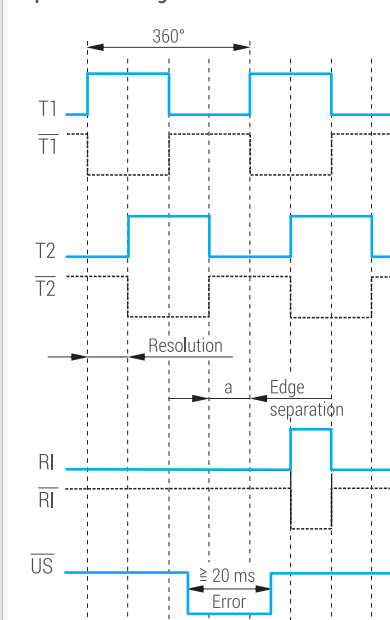

Recommended line receiver circuit

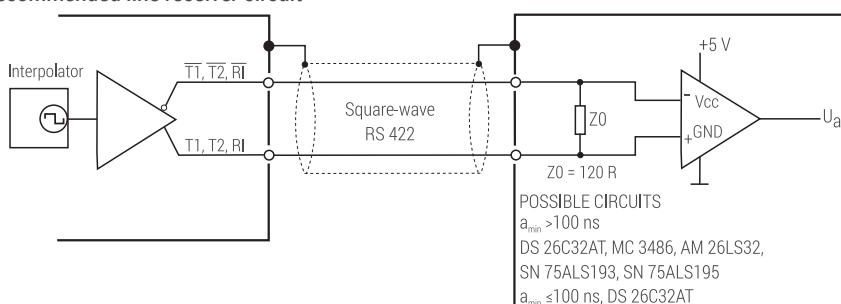

Positive direction of rotation

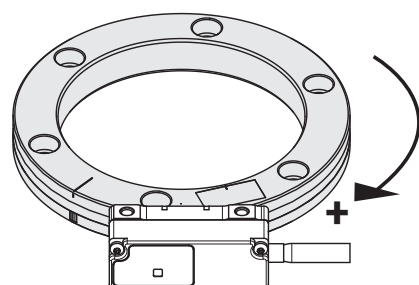

MSR 15 Scanning head with graduation drum - TECHNICAL DATA

SCANNING HEAD

Model	AK MSR 15 1 Vpp	AK MSR 15 TTLx1u	AK MSR 15 TTLx5	AK MSR 15 TTLx10	AK MSR 15 TTLx20	AK MSR 15 TTLx25	AK MSR 15 TTLx50	AK MSR 15 TTLx100	AK MSR 15 TTLx200	
System accuracy	±10"									
System resolution [°]	Dep. on external interpolation	360° / (Lines × 4)	360° / (Lines × 20)	360° / (Lines × 40)	360° / (Lines × 80)	360° / (Lines × 100)	360° / (Lines × 200)	360° / (Lines × 400)	360° / (Lines × 800)	
Interface	~ 1 Vpp									
Integrated interpolation	--	Times 1	Times 5	Times 10	Times 20	Times 25	Times 50	Times 100	Times 200	
Max. output frequency	400 kHz	--	--	--	--	--	--	--	--	
Edge separation a _{min}	--	300 ns	300 ns	300 ns	200 ns	200 ns	100 ns	100 ns	50 ns	
Scanning diameter [mm]	Interpolation error typical	Max. rotational speed [rpm]	Max. rotational speed [rpm]	Max. rotational speed [rpm]	Max. rotational speed [rpm]	Max. rotational speed [rpm]	Max. rotational speed [rpm]	Max. rotational speed [rpm]	Max. rotational speed [rpm]	
50.00	±1.23"	6000	6000	2400	1200	900	700	700	360	360
59.93	±1.03"	5000	5000	2000	1000	750	600	600	300	300
75.06	±0.82"	4000	4000	1600	800	600	450	450	240	240
99.96	±0.62"	3050	3050	1200	600	450	350	350	180	180
103.88	±0.59"	2900	2900	1150	570	430	340	340	170	170
114.17	±0.54"	2650	2650	1050	500	400	320	320	160	160
150.38	±0.41"	2000	2000	800	400	300	240	240	120	120
200.35	±0.31"	1500	1500	600	300	220	180	180	90	90
228.77	±0.27"	1300	1300	500	260	200	160	160	80	80
249.85	±0.25"	1200	1200	480	240	180	140	140	70	70
299.81	±0.21"	1000	1000	400	200	150	120	120	60	60
350.23	±0.18"	870	870	340	170	130	100	100	50	50
Electrical connection	Cable, 0.5 m, 1 m or 3 m with D-sub connector 15-pin (male)									
Voltage supply	+5 V ±10 %									
Power consumption	Max. 880 mW (unloaded)									
Current consumption	Max. 160 mA (unloaded)									
Vibration 55 Hz to 2000 Hz	≤ 150 m/s ² (EN 60 068-2-6)									
Shock 8 ms	≤ 750 m/s ² (EN 60 068-2-27)									
Temperature	Operating temperature: 0 °C to +70 °C, storage temperature: -20 °C to +70 °C									
Mass	Scanning head: 12 g (without cable), connecting cable: 25 g/m, connector: D-sub connector: 28 g									

GRADUATION CARRIER

Model	TTR MSR 15 S: Steel drum with incremental track for mounting with three-point centering TTR MSR 15 A: Aluminum drum with incremental track for mounting with three-point centering											
System accuracy	±10"											
Coefficient of expansion	Steel: α ≈ 16 x 10 ⁻⁶ K ⁻¹ Aluminum: α ≈ 23.4 x 10 ⁻⁶ K ⁻¹											
Reference mark	<ul style="list-style-type: none"> One reference mark at 0°-position (S) Distance-coded on request 											
Scanning diameter [mm]	50.00	59.93	75.06	99.96	103.88	114.17	150.38	200.35	228.77	249.85	299.81	350.23
Inside diameter [mm]	30	40	55	80	80	95	130	180	209	230	280	330
Lines	3960	4740	5928	7884	8192	9000	11 844	15 768	18 000	19 656	23 580	27 540
Moment of inertia [10 ⁻³ kgm ²]	S ≈ 0.03 A ≈ 0.01	≈ 0.07 ≈ 0.02	≈ 0.15 ≈ 0.05	≈ 0.39 ≈ 0.13	≈ 0.50 ≈ 0.17	≈ 0.58 ≈ 0.20	≈ 1.49 ≈ 0.51	≈ 3.70 ≈ 1.27	≈ 5.51 ≈ 1.88	≈ 7.30 ≈ 2.49	≈ 12.80 ≈ 4.37	≈ 21.25 ≈ 7.26
Mass [g]	S ≈ 79 A ≈ 27	≈ 101 ≈ 34	≈ 135 ≈ 46	≈ 189 ≈ 65	≈ 234 ≈ 80	≈ 212 ≈ 72	≈ 302 ≈ 103	≈ 409 ≈ 140	≈ 459 ≈ 140	≈ 507 ≈ 173	≈ 609 ≈ 208	≈ 734 ≈ 251

CONFORMITIES AND CERTIFICATIONS

RoHS	2011/65/EU, 2015/863/EU
EMV	2014/30/EU
UL-Product-Certifications	B 022705 0009, U8V 022705 0005, CB 022705 0006

OPTIONAL ACCESSORIES

Mounting aid:

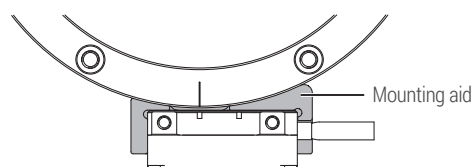

MSR 15 Scanning head with graduation drum - DIMENSIONS, MOUNTING TOLERANCES

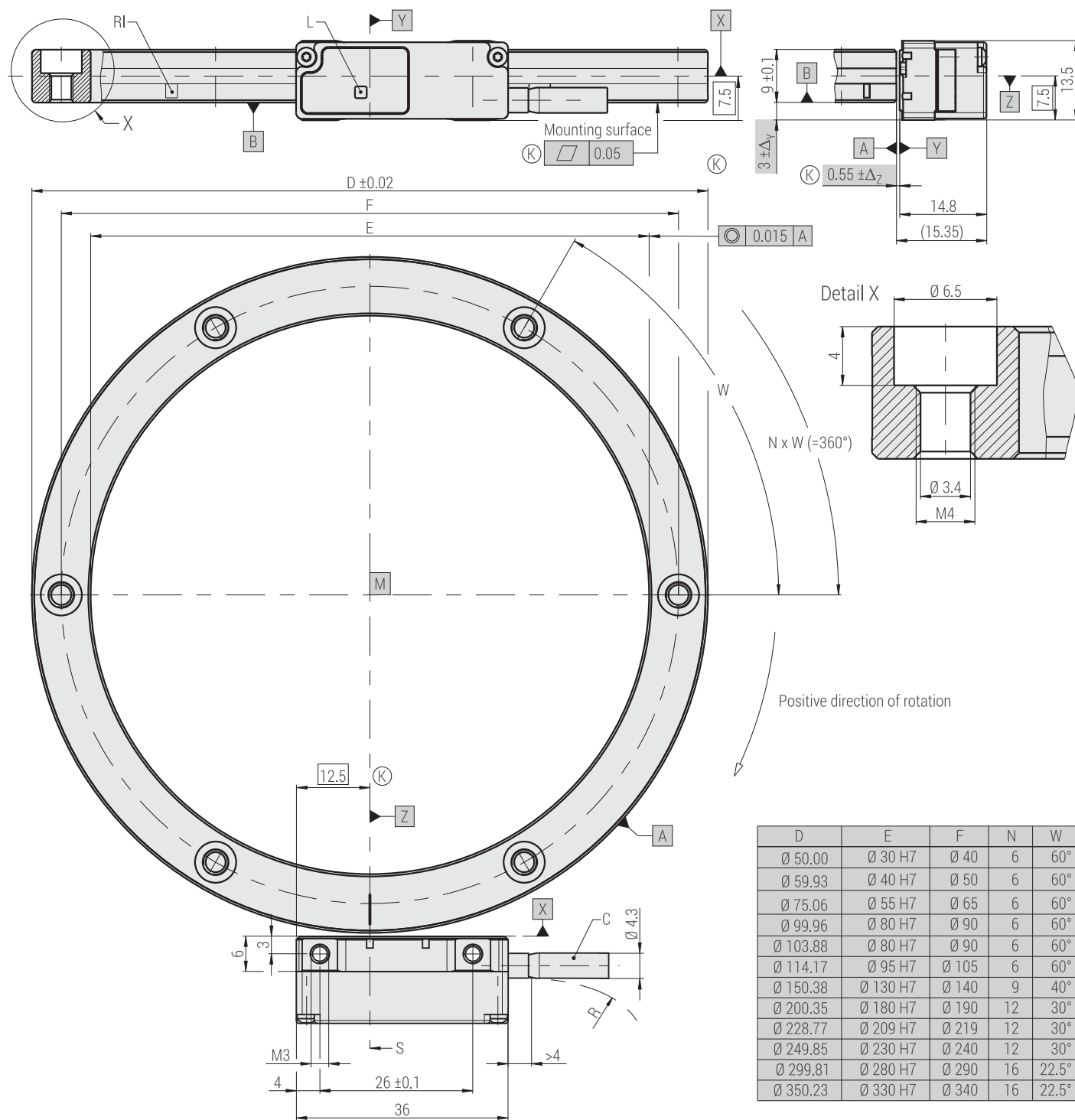

- M = Rotary axis
- RI = Reference mark
- S = Optical centerline and mark for 0° position
- (K) = Required mating dimensions
- RI = Reference mark(s)
- C = Cable
- L = LED function display
- R = Bending radius: stat. R > 8 mm, dyn. R > 20 mm

Permissible position deviation scanning head – drum [A][B]

Δ_y = Displacement, ± 0.5
 Δ_z = Gap tolerance, ± 0.15

$\phi_z = \pm 1.00$ mrad or $\pm 0.06^\circ$ (yaw angle)
 $\phi_y = \pm 1.50$ mrad or $\pm 0.09^\circ$ (pitch angle)
 $\phi_x = \pm 4.00$ mrad or $\pm 0.23^\circ$ (roll angle)

mm



Tolerancing ISO 8015
 ISO 2768: 1989 - m H
 < 6 mm: ± 0.2 mm

MSR 15 Scanning head with tape scale ring - TECHNICAL DATA

SCANNING HEAD

Model	AK MSR 15 1 Vpp	AK MSR 15 TTLx1u	AK MSR 15 TTLx5	AK MSR 15 TTLx10	AK MSR 15 TTLx20	AK MSR 15 TTLx25	AK MSR 15 TTLx50	AK MSR 15 TTLx100	AK MSR 15 TTLx200	
System accuracy	±10"									
System resolution [°]	Dep. on external interpolation	360° / (Lines × 4)	360° / (Lines × 20)	360° / (Lines × 40)	360° / (Lines × 80)	360° / (Lines × 100)	360° / (Lines × 200)	360° / (Lines × 400)	360° / (Lines × 800)	
Interface	~ 1 Vpp									
Integrated interpolation	--	Times 1	Times 5	Times 10	Times 20	Times 25	Times 50	Times 100	Times 200	
Max. output frequency	400 kHz	--	--	--	--	--	--	--	--	
Edge separation a _{min}	--	300 ns	300 ns	300 ns	200 ns	200 ns	100 ns	100 ns	50 ns	
Scanning diameter [mm]	Interpolation error typical	Max. rotational speed [rpm]	Max. rotational speed [rpm]	Max. rotational speed [rpm]	Max. rotational speed [rpm]	Max. rotational speed [rpm]	Max. rotational speed [rpm]	Max. rotational speed [rpm]	Max. rotational speed [rpm]	
59.93	±1.03"	5000	5000	2000	1000	750	600	600	300	300
75.06	±0.82"	4000	4000	1600	800	600	450	450	240	240
99.96	±0.62"	3050	3050	1200	600	450	350	350	180	180
103.88	±0.59"	2900	2900	1150	570	430	340	340	170	170
114.17	±0.54"	2650	2650	1050	500	400	320	320	160	160
150.38	±0.41"	2000	2000	800	400	300	240	240	120	120
200.35	±0.31"	1500	1500	600	300	220	180	180	90	90
228.77	±0.27"	1300	1300	500	260	200	160	160	80	80
249.85	±0.25"	1200	1200	480	240	180	140	140	70	70
299.81	±0.21"	1000	1000	400	200	150	120	120	60	60
350.23	±0.18"	870	870	340	170	130	100	100	50	50
Electrical connection	Cable, 0.5 m, 1 m or 3 m with D-sub connector 15-pin (male)									
Voltage supply	+5 V ±10 %									
Power consumption	Max. 880 mW (unloaded)									
Current consumption	Max. 160 mA (unloaded)									
Vibration 55 Hz to 2000 Hz	≤ 150 m/s ² (EN 60 068-2-6)									
Shock 8 ms	≤ 750 m/s ² (EN 60 068-2-27)									
Temperature	Operating temperature: 0 °C to +70 °C, storage temperature: -20 °C to +70 °C									
Mass	Scanning head: 12 g (without cable), connecting cable: 25 g/m, connector: D-sub connector: 28 g									

GRADUATION CARRIER

Model	MBR MSR 15: Steel tape scale ring										
System accuracy	±10"										
Coefficient of expansion	Steel: α ≈ 10 × 10 ⁻⁶ K ⁻¹										
Reference mark	<ul style="list-style-type: none"> One reference mark (standard) Distance-coded on request 										
Scanning diameter [mm]	59.93	75.06	99.96	103.88	114.17	150.38	200.35	228.77	249.85	299.81	350.23
Lines	4740	5928	7884	8192	9000	11 844	15 768	18 000	19 656	23 580	27540
Moment of inertia [10 ⁻³ kgm ²]	≈ 0.003	≈ 0.005	≈ 0.012	≈ 0.014	≈ 0.018	≈ 0.041	≈ 0.097	≈ 0.144	≈ 0.188	≈ 0.325	≈ 0.518
Mass [g]	≈ 2.9	≈ 3.6	≈ 4.8	≈ 5.0	≈ 5.5	≈ 7.3	≈ 9.7	≈ 11.0	≈ 12.1	≈ 14.5	≈ 16.9

CONFORMITIES AND CERTIFICATIONS

RoHS	2011/65/EU, 2015/863/EU
EMV	2014/30/EU
UL-Product-Certifications	B 022705 0009, U8V 022705 0005, CB 022705 0006

OPTIONAL ACCESSORIES

Mounting aid:

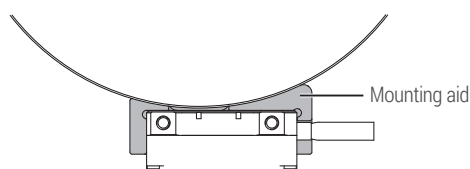

MSR 15 Scanning head with tape scale ring - DIMENSIONS, MOUNTING TOLERANCES

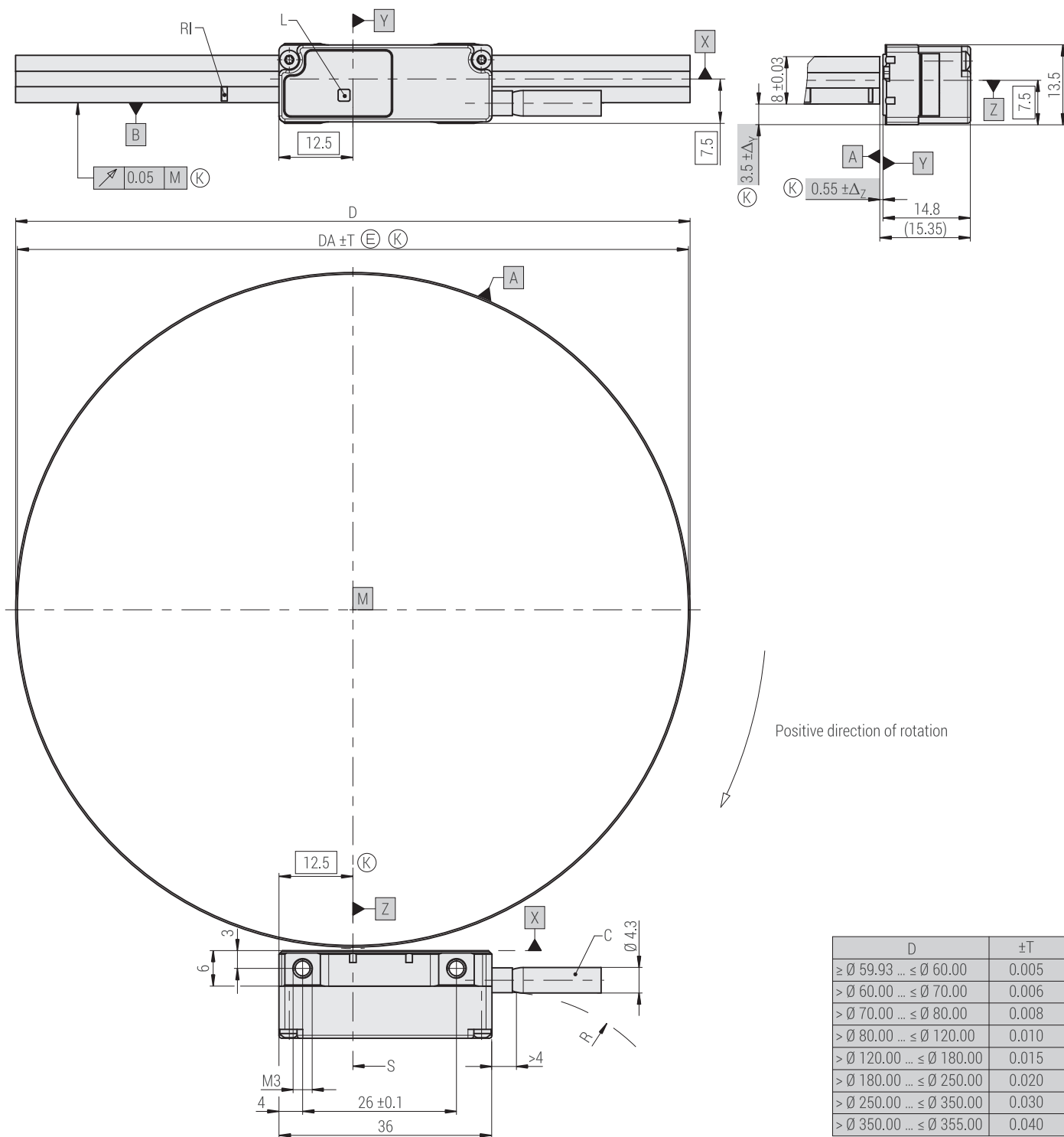

mm

 Tolerancing ISO 8015
 ISO 2768: 1989 - m H
 < 6 mm: ±0.2 mm

LPR = Lines per revolution
 M = Rotation axis
 D = Scanning diameter
 DA = Mating diameter
 Calculation: DA = D - 0.5
 T = Tolerance mating diameter
 S = Optical centerline
 (K) = Required mating dimensions
 RI = Reference mark(s)

C = Cable
 L = LED function display
 R = Bending radius:
 stat. R ≥ 8 mm, dyn. R ≥ 20 mm

Permissible position deviation scanning head – shaft (A) (B)
 Δ_Y = Displacement, ±0.5
 Δ_Z = Gap tolerance, ±0.15
 φ_Z = ±1.00 mrad or ±0.06° (yaw angle)
 φ_Y = ±1.50 mrad or ±0.09° (pitch angle)
 φ_X = ±4.00 mrad or ±0.23° (roll angle)

MSS 15 Scanning head with tape scale segment - TECHNICAL DATA

SCANNING HEAD

Model	AK MSS 15 1 Vpp	AK MSS 15 TTLx1u	AK MSS 15 TTLx5	AK MSS 15 TTLx10	AK MSS 15 TTLx20	AK MSS 15 TTLx25	AK MSS 15 TTLx50	AK MSS 15 TTLx100	AK MSS 15 TTLx200
Interface	~	⌋	⌋	⌋	⌋	⌋	⌋	⌋	⌋
Measuring step [°]	Dep. on external interpolation	360° / (LPR × 4)	360° / (LPR × 20)	360° / (LPR × 40)	360° / (LPR × 80)	360° / (LPR × 100)	360° / (LPR × 200)	360° / (LPR × 400)	360° / (LPR × 800)
Integrated interpolation	--	Times 1	Times 5	Times 10	Times 20	Times 25	Times 50	Times 100	Times 200
Max. circumferential speed at scanning diameter D	10.00 m/s	10.00 m/s	6.40 m/s	3.20 m/s	2.40 m/s	1.92 m/s	1.92 m/s	0.96 m/s	0.96 m/s
Max. output frequency	250 kHz	--	--	--	--	--	--	--	--
Edge separation a_{min}	--	500 ns	300 ns	300 ns	200 ns	200 ns	100 ns	100 ns	50 ns
Interpolation error (typ.)	±(60)"/D								
Electrical connection	Cable, 0.5 m, 1 m or 3 m with D-sub connector 15-pin (male)								
Voltage supply	+5 V ±10 %								
Power consumption	Max. 880 mW (unloaded)								
Current consumption	Max. 160 mA (unloaded)								
Vibration 40 Hz – 2000 Hz Shock 8 ms	≤ 150 m/s ² (EN 60 068-2-6) ≤ 750 m/s ² (EN 60 068-2-27)								
Temperature	Operating temperature: 0 °C to +70 °C, storage temperature: -20 °C to +70 °C								
Mass	Scanning head AK: 12 g, cable: 25 g/m, D-sub connector: 28 g								

GRADUATION CARRIER

Model	MB MSS 15: Steel tape scale segment with adhesive tape (SK)
Coefficient of expansion	$\alpha \approx 10 \times 10^{-6} \text{ K}^{-1}$
Possible scanning diameter	> 75 mm to ≤ 1000 mm (at larger diameters MS 15 applicable) ≤ 75 mm on request
Accuracy of the grating (based on neutral axis)	±15 µm/m
Theoretical lines per revolution (360°)	$LPR = 78.5398 \times D + 33.1942$ (round down result to integer)*
Reference mark	<ul style="list-style-type: none"> Standard: One reference mark at any position within the measuring range On request: Additional or distance-coded reference marks
Mass	20 g/m (SK)

* Deviations of the scanning diameter influence the accuracy.

CONFORMITIES AND CERTIFICATIONS

RoHS	2011/65/EU, 2015/863/EU
EMV	2014/30/EU
UL-Product-Certifications	B 022705 0009, U8V 022705 0005, CB 022705 0006

OPTIONAL ACCESSORIES

Mounting aid:

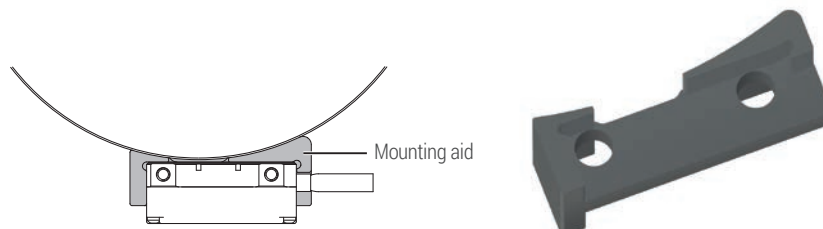

MSS 15 Scanning head with tape scale segment - DIMENSIONS, MOUNTING TOLERANCES

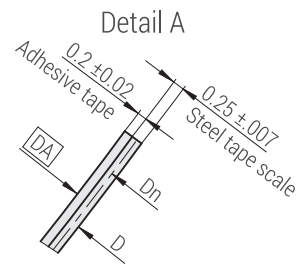
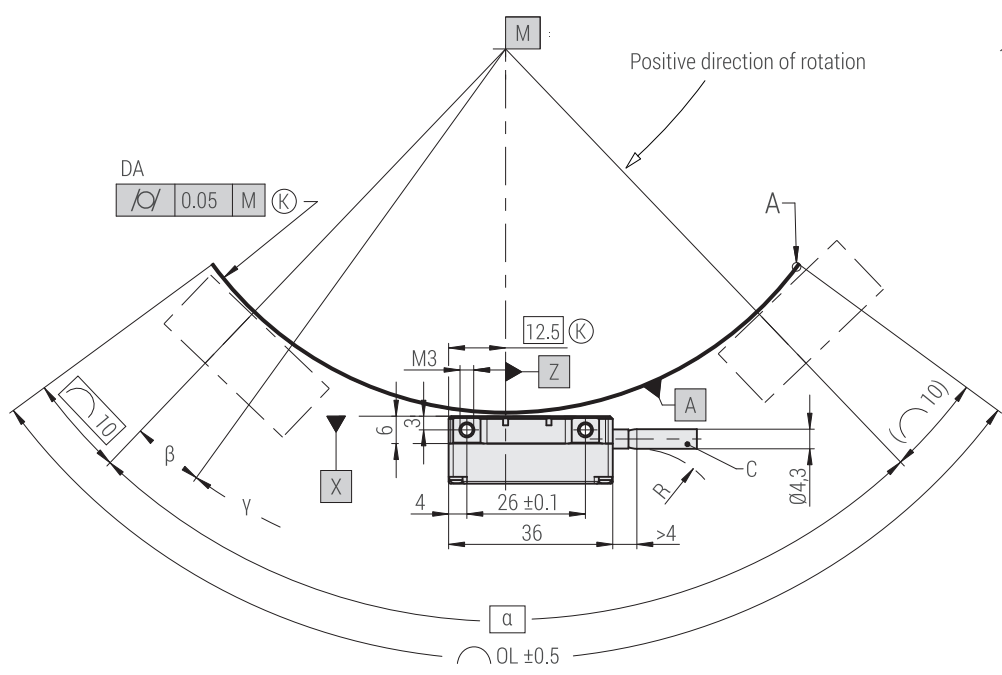
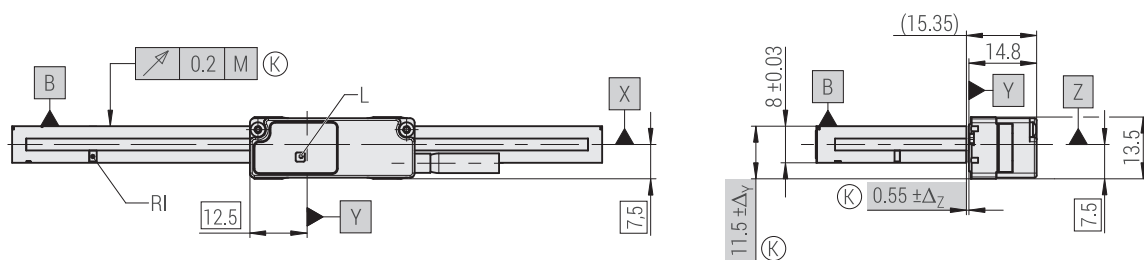

- | | |
|----------------------------------------------------------------------------------------------------------------------------|------------------------------------------------------------------------------------------------|
| M = Rotary axis | C = Cable |
| OL = Length of tape
Calculation: $OL = 20 + (D - 0.25) \times \pi \times a / 360^\circ$
(round up result to integer) | L = LED function display |
| a = Measuring range [°] | R = Bending radius: stat. $R \geq 8$ mm, dyn. $R \geq 20$ mm |
| D = Scanning diameter | Permissible position deviation scanning head – scale tape $\begin{matrix} A \\ B \end{matrix}$ |
| DA = Mating diameter
Calculation: $DA = D - 0.90$ | Δ_y = Displacement, ± 0.5 |
| Dn = Neutral axis | Δ_z = Gap tolerance, ± 0.15 |
| (K) = Required mating dimensions | φ_z = ± 1.00 mrad or $\pm 0.06^\circ$ (yaw angle) |
| RI = Reference mark(s) | φ_y = ± 1.50 mrad or $\pm 0.09^\circ$ (pitch angle) |
| β = Any position of the reference mark
from the beginning of measuring range [°] | φ_x = ± 4.00 mrad or $\pm 0.23^\circ$ (roll angle) |
| γ = Additional reference mark [°] | |

mm

 Tolerancing ISO 8015
 ISO 2768: 1989 - m H
 < 6 mm: ± 0.2 mm

ACCESSORY: EXTERNAL TESTING DEVICE PWT 101

Even though the MSx 15 angle encoders allow large mechanical mounting tolerances, it is recommended to control the function of counting signals and reference impulse.

The signals can be controlled directly via the integrated LED function control or connected to an oscilloscope and checked for conformity with signal specifications. The last mentioned method requires some effort.

The PWT 101 is a testing device for checking the function of RSF Elektronik encoders. At encoders with pin assignment according to RSF Elektronik standard (see page 06) the pinout adapter PA2 must be used additionally. At alternative pin assignments other pinout adapters could be necessary.

Thanks to its compact dimensions and robust design, the PWT 101 is ideal for mobile use. A 4.3-inch touchscreen provides for display and operation.



AVAILABLE FUNCTIONS

The performance range of the PWT 101 can be expanded by firmware update. Appropriate firmware files that can be imported to the PWT 101 through a memory card (not included in delivery) will be made available at www.heidenhain.de.



STATUS DISPLAY VIA LED FUNCTION

STATUS DISPLAY AT THE SCANNING HEAD	INFORMATION	NOTE
Without external test box		
Function-control main track		
▪ LED displays GREEN	Counting signals very good	After successful mounting
▪ LED blinks GREEN	Counting signals good	At mounting not allowed → allowed during operation
▪ LED blinks RED	Counting signals out of tolerance → error	Check mounting, clean scale
Function-control reference impulse RI		
▪ LED blinks BLUE	RI within tolerance	Only by passing the reference mark
▪ LED blinks RED	RI out of tolerance	Check mounting, clean graduation carrier
With external test box		
Function-control main track		
▪ LED displays GREEN	Scanning head supplied with power	Evaluation of counting signals via LED not active
Function-control reference impulse RI		
▪ LED blinks BLUE	RI within tolerance	Only by passing the reference mark
▪ LED blinks RED	RI out of tolerance	Check mounting, clean graduation carrier

FURTHER PRODUCTS

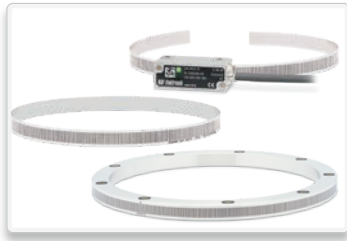

MCR 15 | MCS 15

Absolute modular angle encoders with small dimensions

- Divers serial interfaces
- Status display directly at the scanning head via LED function
- Easy mounting as a result of large mounting tolerances
- High insensitivity against contaminations
- Possible drum diameter (TTR): 50.00 mm to 350.23 mm (outside)
- Possible scanning diameter (MBR): 59.93 mm to 350.23 mm (outside)
- Steel tape scale (MSS) from \varnothing 75 mm

MSR 45

Modular angle encoders with steel tape scale - various versions

- Full-circle or segment version
- Grating period: 200 μ m
- Accuracy of the grating (stretched): ± 30 μ m/m
- High permissible rotational speed resp. circumferential speed
- Integrated subdividing: up to times 100
- Possible diameter: Full-circle from \varnothing 146.99 mm
Segment from \varnothing 150 mm



MC 15

Absolute linear encoders with status display

- Divers serial interfaces
- Status display directly at the scanning head via LED function
- Easy mounting as a result of large mounting tolerances
- High insensitivity against contaminations
- Max. measuring length
Steel tape scale: 10 000 mm

MS 15

Exposed linear encoders with integrated mounting control

- Easy mounting; no test box or oscilloscope needed
- Quality of the scanning signals is directly visible at the scanning head via a tricolored LED function
- Two independent switch tracks for individual special functions
- Position of reference mark selectable by customer
- High insensitivity against contamination
- High permissible traversing speed
- Integrated subdividing: up to times 200
- Max. measuring length:
Steel tape scale: 20 000 mm
Glass scale: 3140 mm

MS 45

Exposed linear encoders with integrated mounting control

- Easy mounting; no test box or oscilloscope needed
- Quality of the scanning signals is directly visible at the scanning head via a tricolored LED function
- Flat dimensions
- Easy mounting due to large mounting tolerances
- High insensitivity against contamination
- High permissible traversing speed
- Integrated subdividing: up to times 100
- Max. measuring length:
Steel tape scale: 30 000 mm

DISTRIBUTION CONTACTS

AUSTRIA <i>Corporate Head Quarters</i>	RSF Elektronik Ges.m.b.H.	A-5121 Tarsdorf 93	☎ +43 62 78 81 92-0 FAX +43 62 78 81 92-79	e-mail: info@rsf.at internet: www.rsf.at
BELGIUM	HEIDENHAIN NV/SA	Pamelse Klei 47 1760 Roosdaal	☎ +32 (54) 34 3158 FAX +32 (54) 34 3173	e-mail: sales@heidenhain.be internet: www.heidenhain.be
FRANCE	HEIDENHAIN FRANCE sarl	2 Avenue de la Christallerie 92310 Sèvres	☎ +33 1 41 14 30 00 FAX +33 1 41 14 30 30	e-mail: info@heidenhain.fr internet: www.heidenhain.fr
GREAT BRITAIN	HEIDENHAIN (GB) Ltd.	200 London Road Burgess Hill West Sussex RH15 9RD	☎ +44 1444 247711 FAX +44 1444 870024	e-mail: sales@heidenhain.co.uk internet: www.heidenhain.co.uk
ITALY	HEIDENHAIN ITALIANA S.r.l.	Via Asiago, 14 20128 Milan	☎ +39 02 27075-1 FAX +39 02 27075-210	e-mail: info@heidenhain.it internet: www.heidenhain.it
NETHERLANDS	HEIDENHAIN NEDERLAND B.V.	Copernicuslaan 34 6716 BM EDE	☎ +31 318-581800 FAX +31 318-581870	e-mail: verkoop@heidenhain.nl internet: www.heidenhain.nl
SPAIN	FARRESA ELECTRONICA S.A	Les Corts 36-38 08028 Barcelona	☎ +34 93 4 092 491 FAX +34 93 3 395 117	e-mail: farresa@farresa.es internet: www.farresa.es
SWEDEN	HEIDENHAIN Scandinavia AB	Storsåtragränd 5 SE-12739 Skärholmen	☎ +46 8 531 933 50 FAX +46 8 531 933 77	e-mail: sales@heidenhain.se internet: www.heidenhain.se
SWITZERLAND	HEIDENHAIN (SCHWEIZ) AG	Vieristrasse 14 8603 Schwerzenbach	☎ +41 44 806 27 27 FAX +41 44 806 27 28	e-mail: verkauf@heidenhain.ch internet: www.heidenhain.ch
CHINA	DR. JOHANNES HEIDENHAIN (CHINA) Co., Ltd	Tian Wei San Jie, Area A, Beijing Tianzhu Airport Industrial Zone Shunyi District, Beijing 101312	☎ +86 10 80 42-0000	e-mail: sales@heidenhain.com.cn internet: www.heidenhain.com.cn
ISRAEL	MEDITAL Hi-Tech	7 Leshem Str. 47170 Petach Tikva	☎ +972 0 3 923 33 23 FAX +972 0 3 923 16 66	e-mail: avi@medital.co.il internet: www.medital.co.il
JAPAN	HEIDENHAIN K.K.	Hulic Kojimachi Bldg., 9F 3-2 Kojimachi, Chiyoda-ku Tokyo, 102-0083	☎ +81 3 3234 7781 FAX +81 3 3262 2539	e-mail: sales@heidenhain.co.jp internet: www.heidenhain.co.jp
KOREA	HEIDENHAIN LTD.	75, Jeonpa-ro 24beon-gil, Manan-gu, Anyang-si 14087 Gyeonggi-do	☎ +82 31 380 5200 FAX +82 31 380 5250	e-mail: info@heidenhain.co.kr internet: www.heidenhain.co.kr
SINGAPORE	HEIDENHAIN PACIFIC PTE LTD.	51, Ubi Crescent 408593 Singapore	☎ +65 67 49 32 38 FAX +65 67 49 39 22	e-mail: info@heidenhain.com.sg internet: www.heidenhain.com.sg
TAIWAN	HEIDENHAIN CO., LTD.	No. 29, 33rd Road; Taichung Industrial Park Taichung 40768	☎ +886 4 2358 89 77 FAX +886 4 2358 89 78	e-mail: info@heidenhain.tw internet: www.heidenhain.com.tw
USA	HEIDENHAIN CORPORATION	333 East State Parkway Schaumburg, IL 60173-5337	☎ +1 847 490 11 91	e-mail: info@heidenhain.com internet: www.heidenhain.com

Date 01/2024 ■ Art.No. 1277165-02 ■ Doc.No. D1277165-05-A-01 ■ Technical adjustments in reserve!



RSF Elektronik

Ges.m.b.H.

Linear and Angle Encoders
Precision Graduations

Certified acc. to
ISO 9001
ISO 14001

