

- (K) = Kundenseitige Anschlussmaße Required mating dimensions
- (H1) = Klebefläche Adhesive surface
- (H2) = Flanschdose M12 - 8-pol. Flange socket M12, 8-pin.
- (H3) = Klettverschluss zur Befestigung Velcro fastener for attachment
- (H4) = Klebspalt vollständig gefüllt mit 2-Komponentenkleber: Plexus MA300 Adhesion gap, completely filled with Plexus MA300 two-component adhesive
- (H5) = Justiermarke Alignment mark
- (H6) = Erdungsanschluss Earth connection

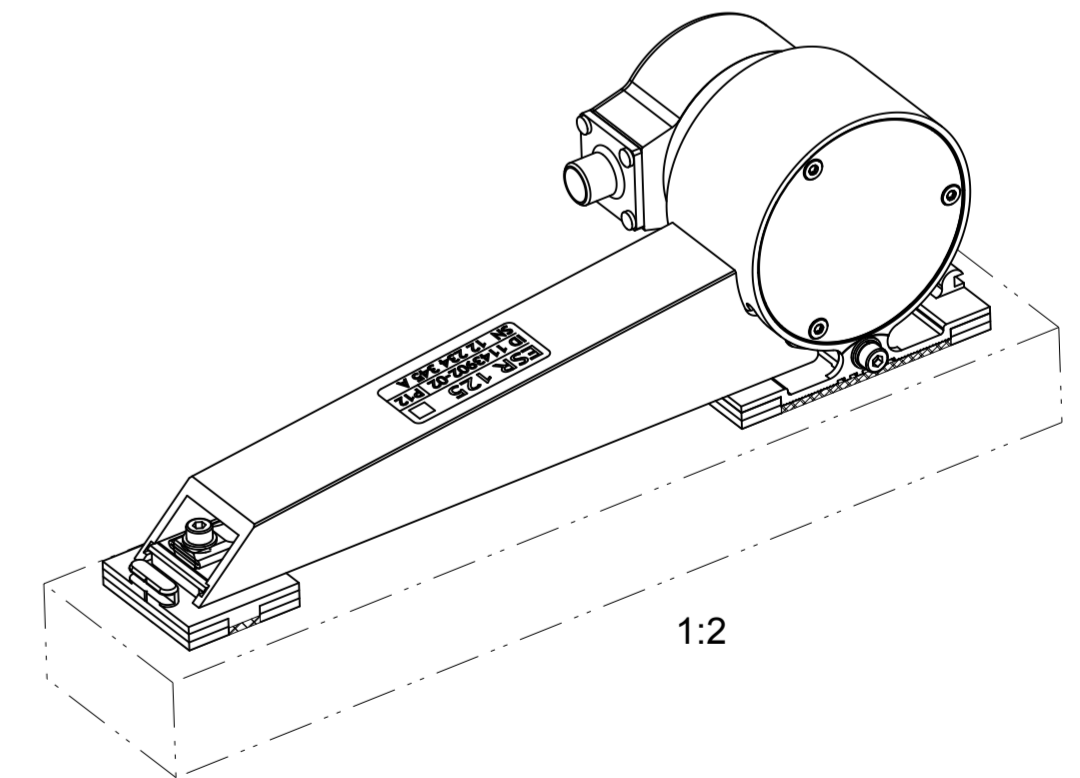
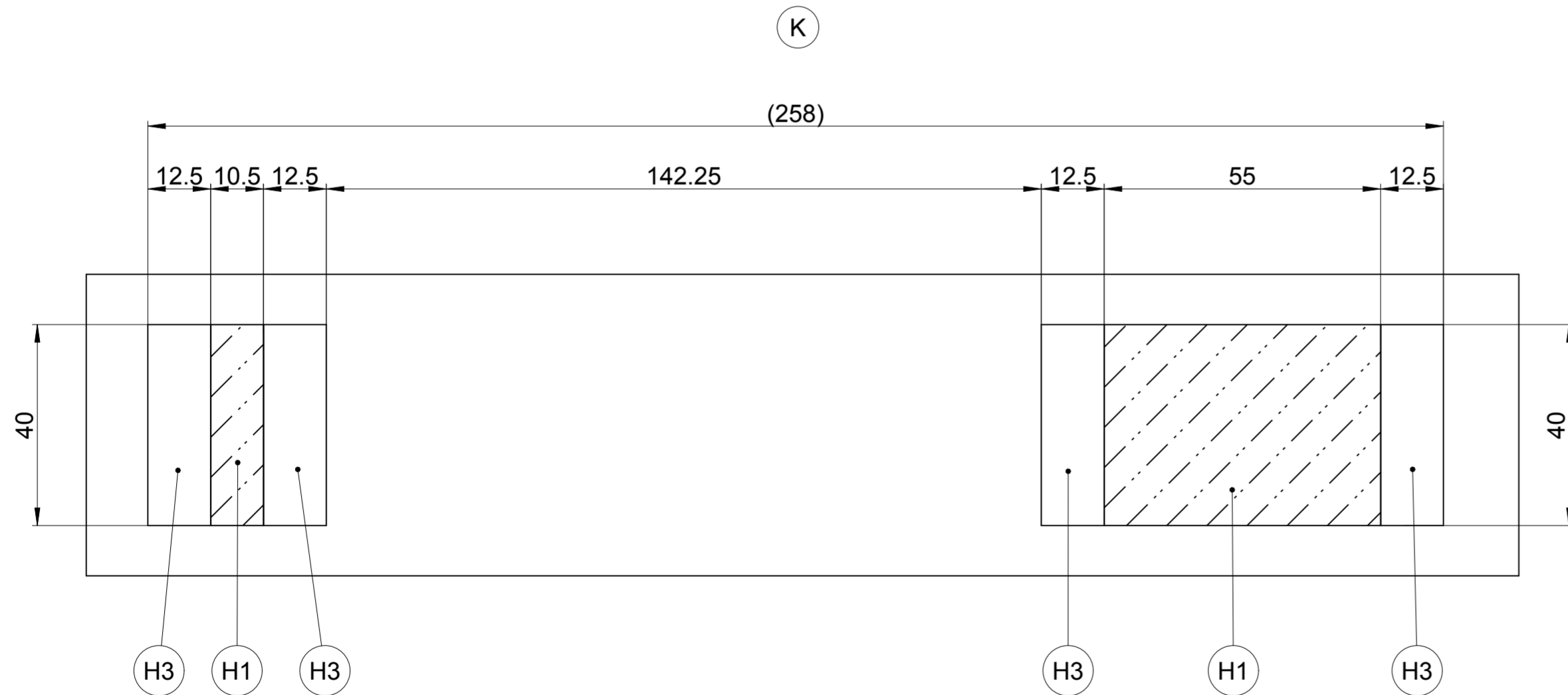

Original drawing Scale: 1:1 Format: A2 Dimensions in mm: 1:1 A2		ESR 225 ESR 225 Anschlussmaße / Mating Dimensions	ID number: Change No. C053970-5 Phase: Serie Tolerierung nach DIN ISO 8015 Tolerances as per DIN ISO 8015 Allgemeintol. ISO 2768-mH ± 0.2 General tol. ISO 2768-mH ± 0.2
The reproduction, distribution and utilization of this document as well as the communication of its contents to others without express authorization is prohibited. Offenders will be held liable for the payment of damages. All rights reserved in the event of the grant of a patent, utility model or design. (ISO 16016)			Version Revision Sheet Page D1224393-00 - B-01 1 1 Document number