



HEIDENHAIN



ND 5023

Operating Instructions

Digital Readout

English (en)
12/2023

Contents

1	Fundamentals	11
2	Safety	19
3	Transport and storage	25
4	Mounting	29
5	Installation	35
6	Fundamentals of positioning	41
7	Basic operation	49
8	Commissioning	65
9	Milling specific operations	91
10	Turning specific operations	119
11	External operation	131
12	Reference tables	133
13	Settings	147
14	Service and maintenance	155
15	What to do if	159
16	Removal and disposal	161
17	Specifications	163

1	Fundamentals.....	11
1.1	About these instructions.....	12
1.2	Information on the product.....	12
1.3	Notes on reading the documentation.....	13
1.4	Storage and distribution of the documentation.....	14
1.5	Target group for the instructions.....	14
1.6	Notes in this documentation.....	15
1.7	Symbols and fonts used for marking text.....	17
2	Safety.....	19
2.1	Overview.....	20
2.2	General safety precautions.....	20
2.3	Intended use.....	20
2.4	Improper use.....	21
2.5	Personnel qualification.....	21
2.6	Obligations of the operating company.....	22
2.7	General safety precautions.....	22
2.7.1	Symbols in the instructions.....	22
2.7.2	Symbols on the product.....	23
2.7.3	Electrical safety instructions.....	24
3	Transport and storage.....	25
3.1	Overview.....	26
3.2	Unpacking.....	26
3.3	Items supplied and accessories.....	26
3.4	In case of damage in transit.....	27
3.5	Repackaging and storage.....	27

4	Mounting.....	29
4.1	Overview.....	30
4.2	Assembly.....	30
4.3	Mounting on Single-Pos stand.....	31
4.4	Mounting on Multi-Pos holder.....	32
4.5	Mounting in a mounting frame.....	33
4.6	Mounting a cover.....	34
5	Installation.....	35
5.1	Overview.....	36
5.2	General information.....	36
5.3	Product overview.....	37
5.4	Connecting an encoder.....	38
5.5	Connecting a USB device.....	38
5.6	Connecting the line voltage.....	39
6	Fundamentals of positioning.....	41
6.1	Overview.....	42
6.2	Datums.....	42
6.3	Actual position, nominal position, and Distance-To-Go.....	42
6.4	Absolute workpiece positions.....	43
6.5	Incremental workpiece positions.....	44
6.6	Zero angle reference axis.....	45
6.7	Reading head position.....	46
6.8	Encoder reference marks.....	47

7	Basic operation.....	49
7.1	Overview.....	50
7.2	Front panel and keys.....	50
7.3	Switch-on/Switch-off.....	51
7.3.1	Switch-on.....	51
7.3.2	Switch-off.....	51
7.4	User interface.....	52
7.4.1	Display layout.....	52
7.4.2	Soft keys.....	53
7.4.3	Graphic positioning aid.....	54
7.4.4	Operating modes.....	54
7.4.5	Stopwatch.....	55
7.4.6	Calculator.....	57
7.4.7	Help.....	58
7.4.8	Data input forms.....	58
7.4.9	Reference mark evaluation.....	59
7.4.10	Selecting a specific reference mark.....	61
7.4.11	Error messages.....	61
7.4.12	Setup menus.....	61
7.5	User Management.....	62
7.5.1	Supervisor Login.....	62
7.5.2	User Job Settings.....	62

8	Commissioning.....	65
8.1	Overview.....	66
8.2	Installation Guide.....	67
8.3	Installation Setup.....	68
8.3.1	File management.....	68
8.3.2	Encoder Setup.....	75
8.3.3	Display Configuration.....	76
8.3.4	Readout Settings.....	77
8.3.5	Diagnostics.....	78
8.3.6	Display Color Scheme.....	78
8.3.7	Factory defaults.....	79
8.3.8	Error Compensation.....	79
8.3.9	Backlash compensation.....	84
8.4	Job Setup.....	85
8.4.1	Units.....	85
8.4.2	Scale Factor.....	86
8.4.3	Diameter Axes.....	86
8.4.4	Graphic positioning aid.....	87
8.4.5	Status Bar Settings.....	87
8.4.6	Stopwatch.....	87
8.4.7	Display Settings.....	89
8.4.8	System Information.....	90
8.4.9	Language.....	90

9 Milling specific operations.....	91
9.1 Overview.....	92
9.2 1/2 soft key.....	92
9.3 Tool Table.....	93
9.3.1 Soft keys.....	93
9.3.2 Importing and exporting.....	94
9.3.3 Tool compensation.....	94
9.3.4 Entering tool data.....	96
9.3.5 Selecting a tool.....	97
9.4 Setting a datum.....	97
9.4.1 Setting a workpiece datum without using the probing function.....	98
9.4.2 Probing with a tool.....	99
9.5 Presetting a target position.....	103
9.5.1 Absolute distance preset.....	104
9.5.2 Incremental distance preset.....	106
9.6 Features.....	107
9.6.1 Circle and linear patterns.....	108
9.6.2 Incline and arc milling.....	113
10 Turning specific operations.....	119
10.1 Overview.....	120
10.2 Tool display icon.....	120
10.3 Tool table.....	120
10.3.1 Importing and exporting.....	120
10.3.2 Setting tool offsets.....	120
10.3.3 Selecting a tool.....	122
10.4 Setting a datum.....	123
10.4.1 Setting a datum manually.....	124
10.4.2 Setting a datum using the Note function.....	125
10.5 Taper Calculator.....	126
10.6 Presets.....	127
10.7 Diameter and radius measurements.....	128
10.8 Vectoring.....	129
10.9 Z coupling.....	130

11 External operation.....	131
11.1 External operation.....	132
12 Reference tables.....	133
12.1 Drill sizes to decimal inches.....	134
12.2 English tap drill sizes.....	142
12.3 Metric tap drill sizes.....	143
12.4 English recommended surface speeds.....	144
12.5 Metric recommended surface speeds.....	145
13 Settings.....	147
13.1 Overview.....	148
13.2 Factory default settings.....	148
13.3 Job Setup.....	148
13.3.1 Units.....	148
13.3.2 Scale Factor.....	149
13.3.3 Diameter Axes.....	149
13.3.4 Graphic Pos Aid.....	149
13.3.5 Status Bar Settings.....	149
13.3.6 Stopwatch.....	150
13.3.7 Display Settings.....	150
13.3.8 Vectoring.....	151
13.3.9 Language.....	151
13.4 Installation Setup.....	152
13.4.1 File Management.....	152
13.4.2 Encoder Setup.....	152
13.4.3 Display Configuration.....	153
13.4.4 Readout Settings.....	154
13.4.5 Diagnostics.....	154
13.4.6 Display Color Scheme.....	154
13.4.7 Factory Defaults.....	154
13.4.8 Error Compensation.....	154
13.4.9 Backlash compensation.....	154

14 Service and maintenance.....	155
14.1 Overview.....	156
14.2 Cleaning.....	156
14.3 Maintenance schedule.....	156
14.4 Resuming operation.....	157
14.5 Resetting to the factory defaults.....	157
15 What to do if.....	159
15.1 Overview.....	160
15.2 Malfunctions.....	160
15.3 Troubleshooting.....	160
16 Removal and disposal.....	161
16.1 Overview.....	162
16.2 Removal.....	162
16.3 Disposal.....	162
17 Specifications.....	163
17.1 Product specifications.....	164
17.2 Product dimensions and mating dimensions.....	165

1

Fundamentals

1.1 About these instructions

These instructions provide all the information and safety precautions needed for the safe operation of the product.

1.2 Information on the product

Product designation	Part number
ND 5023 3 axes	1197249-xx

The ID label is provided on the back of the product.

Example:

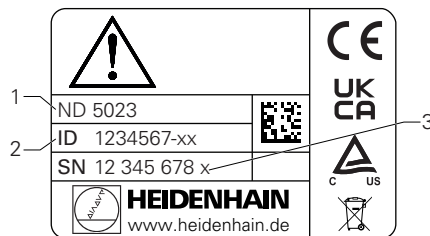

- 1 Product designation
- 2 Part number
- 3 Index

Validity of the documentation

Before using the documentation and the product, you need to verify that the documentation matches the product.

- ▶ Compare the part number and the index indicated in the documentation with the corresponding data given on the ID label of the product
- > If the part numbers and indexes match, the documentation is valid



If the part numbers and indexes do not match so that the documentation is not valid, you will find the current documentation for the product at www.heidenhain.com.

1.3 Notes on reading the documentation

The table below lists the components of the documentation in the order of priority for reading.

⚠ WARNING	
Fatal accidents, personal injury or property damage caused by non-compliance with the documentation!	
Failure to comply with the documentation may result in fatal accidents, personal injury or property damage.	
<ul style="list-style-type: none"> ▶ Read the documentation carefully from beginning to end ▶ Keep the documentation for future reference 	

Documentation	Description
Addendum	An addendum supplements or supersedes the corresponding contents of the Operating Instructions and, if applicable, of the Installation Instructions. If this document is included in the shipment, read it first before you proceed. All other contents of the documentation retain their validity.
Installation Instructions	The Installation Instructions contain all the information and safety precautions needed for the proper mounting and installation of the product. They are an excerpt from the Operating Instructions and are included in every shipment. This document has the second highest priority for reading.
Operating Instructions	The Operating Instructions contain all the information and safety precautions needed for the proper operation of the product according to its intended use. This document has the third highest priority for reading. This documentation can be downloaded from the download area at www.heidenhain.com . The Operating Instructions must be printed prior to commissioning the product.
Documentation of connected measuring devices and other peripherals	These documents are not included in delivery. They are shipped with the respective measuring devices and peripherals.

Would you like any changes, or have you found any errors?

We are continuously striving to improve our documentation for you. Please help us by sending your requests to the following e-mail address:

userdoc@heidenhain.de

1.4 Storage and distribution of the documentation

The instructions must be kept in the immediate vicinity of the workplace and must be available to all personnel at all times. The operating company must inform the personnel where these instructions are kept. If the instructions have become illegible, the operating company must obtain a replacement from the manufacturer. If the product is given or resold to any other party, the following documents must be passed on to the new owner:

- Addendum, if supplied
- Installation Instructions
- Operating Instructions

1.5 Target group for the instructions

These instructions must be read and observed by every person who performs any of the following tasks:

- Mounting
- Installation
- Commissioning
- Setup, programming and operation
- Service, cleaning and maintenance
- Troubleshooting
- Removal and disposal

1.6 Notes in this documentation

Safety precautions

Comply with all safety precautions indicated in these instructions and in your machine tool builder's documentation!

Precautionary statements warn of hazards in handling the product and provide information on their prevention. Precautionary statements are classified by hazard severity and divided into the following groups:

DANGER

Danger indicates hazards for persons. If you do not follow the avoidance instructions, the hazard will **result in death or severe injury**.

WARNING

Warning indicates hazards for persons. If you do not follow the avoidance instructions, the hazard **could result in death or serious injury**.

CAUTION

Caution indicates hazards for persons. If you do not follow the avoidance instructions, the hazard **could result in minor or moderate injury**.

NOTICE

Notice indicates danger to material or data. If you do not follow the avoidance instructions, the hazard **could result in things other than personal injury, like property damage**.

Informational notes

Observe the informational notes provided in these instructions to ensure reliable and efficient operation of the product.

In these instructions, you will find the following informational notes:



The information symbol indicates a **tip**.
A tip provides important additional or supplementary information.



The gear symbol indicates that the function described **depends on the machine**, e.g.

- Your machine must feature a certain software or hardware option
- The behavior of the function depends on the configurable machine settings



The book symbol represents a **cross reference** to external documentation, e.g. the documentation of your machine tool builder or other supplier.

1.7 Symbols and fonts used for marking text

In these instructions the following symbols and fonts are used for marking text:

Format	Meaning
▶ ...	Identifies an action and the result of this action
> ...	Example: <ul style="list-style-type: none">▶ Press the enter key> The parameters are saved and the Job Setup menu is displayed
■ ...	Identifies an item of a list
■ ...	Example: <ul style="list-style-type: none">■ Installation Setup■ Job Setup
Bold	Identifies menus, screens, displays, keys, and soft keys Example: <ul style="list-style-type: none">▶ Press the Setup soft key> The Configuration Menu is displayed.

2

Safety

2.1 Overview

This chapter provides important safety information needed for the proper mounting, installation and operation of the product.

2.2 General safety precautions

General accepted safety precautions, in particular the applicable precautions relating to the handling of live electrical equipment, must be followed when operating the system. Failure to observe these safety precautions may result in personal injury or damage to the product.

It is understood that safety rules within individual companies vary. If a conflict exists between the material contained in these instructions and the rules of a company using this system, the more stringent rules take precedence.

2.3 Intended use

The ND 5023 is an advanced digital readout for use on manually operated machine tools. In combination with linear and angle encoders, the ND 5023 displays the position of the tool in more than one axis and provides further functions for operating the machine tool.

The ND 5023:

- must only be used in commercial applications and in an industrial environment
- must be mounted on a suitable stand or holder to ensure the correct and intended operation of the product
- is intended for indoor use in an environment in which the contamination caused by humidity, dirt, oil and lubricants complies with the requirements of the specifications



The ND 5023 supports the use of a wide variety of peripheral devices from different manufacturers. HEIDENHAIN cannot make any statements on the intended use of these devices. The information on their intended use, which is provided in the associated documentations, must be observed.

2.4 Improper use

When the product is used it must be ensured that no hazard to persons can result. If any such hazard exists, appropriate measures must be taken by the operating company.

In particular, the product must not be used in the following applications:

- Use and storage outside the specifications
- Outdoor use
- Use in potentially explosive atmospheres
- Use of the product as part of a safety function

2.5 Personnel qualification

The personnel for mounting, installation, operation, service, maintenance and removal must be appropriately qualified for this work and must have obtained sufficient information from the documentation supplied with the product and with the connected peripherals.

The personnel required for the individual activities to be performed on the product are indicated in the respective sections of these instructions.

The personnel groups that are responsible for mounting, installation, operation, maintenance and removal have different qualifications and tasks, which are specified as follows.

Operator

The operator uses and operates the product within the framework specified for the intended use. He is informed by the operating company about the special tasks and the potential hazards resulting from incorrect behavior.

Qualified personnel

The qualified personnel are trained by the operating company to perform advanced operation and parameterization. The qualified personnel have the required technical training, knowledge and experience and know the applicable regulations, and are thus capable of performing the assigned work regarding the application concerned and of proactively identifying and avoiding potential risks.

Electrical specialist

The electrical specialist has the required technical training, knowledge and experience and knows the applicable standards and regulations, and is thus capable of performing work on electrical systems and of proactively identifying and avoiding potential risks. Electrical specialists have been specially trained for the environment they work in.

Electrical specialists must comply with the provisions of the applicable legal regulations on accident prevention.

2.6 Obligations of the operating company

The operating company owns or leases the product and the peripherals. It is responsible that the intended use is complied with at all times.

The operating company must:

- Assign the different tasks to be performed on the product to appropriate, qualified, and authorized personnel
- Verifiably train personnel in the tasks they are allowed to perform and how to perform them
- Provide all materials and means necessary in order for personnel to complete the assigned tasks
- Ensure that the product is operated only when in perfect technical condition
- Ensure that the product is protected from unauthorized use

2.7 General safety precautions



 The safety of any system incorporating the use of this product is the responsibility of the assembler or installer of the system.

 The product supports the use of a wide variety of peripheral devices from different manufacturers. HEIDENHAIN cannot make any statements on the specific safety precautions to be taken for these devices. The safety precautions provided in the respective documentations must be observed. If no such information has been supplied, it must be obtained from the manufacturers concerned.

The specific safety precautions required for the individual activities to be performed on the product are indicated in the respective sections of these instructions.



2.7.1 Symbols in the instructions

The following safety symbols are used in this manual:

Symbol	Meaning
	Identifies information that warns of personal injury
	Identifies electrostatic sensitive devices (ESD)
	ESD wristband for personal grounding

2.7.2 Symbols on the product

The following symbols are used to identify the product:

Symbol	Meaning
	Observe the safety precautions regarding electricity and power connection before you connect the product
	Earth (ground) terminal as per IEC 60417 - 5017. Observe the information on installation.

2.7.3 Electrical safety instructions

WARNING

Hazard of contact with live parts when opening the product.

This may result in electric shock, burns or death.

- ▶ Never open the housing
- ▶ Only the manufacturer is permitted to access the inside of the product

WARNING

Hazard of dangerous amount of electricity passing through the human body upon direct or indirect contact with live electrical parts.

This may result in electric shock, burns or death.

- ▶ Work on the electrical system and live electrical components is to be performed only by trained specialists
- ▶ For power connection and all interface connections, use only cables and connectors that comply with applicable standards
- ▶ Have the manufacturer exchange defective electrical components immediately
- ▶ Regularly inspect all connected cables and all connections on the product. Defects, such as loose connections or scorched cables, must be removed immediately

NOTICE

Damage to internal parts of the product!

Opening the product will result in forfeiture of warranty and guarantee.

- ▶ Never open the housing
- ▶ Only the product manufacturer is permitted to access the inside of the product

3

**Transport and
storage**

3.1 Overview

This chapter contains all of the information necessary for the transportation and storage of the product and provides an overview of the items supplied and the available accessories for the product.

3.2 Unpacking

- ▶ Open the top lid of the box
- ▶ Remove the packaging materials
- ▶ Unpack the contents
- ▶ Check the delivery for completeness
- ▶ Check the delivery for damage

3.3 Items supplied and accessories

Items supplied

The following items are included in the shipment:

- Product
- Single-Pos stand
- Rubber feet
- Cover
- Installation instructions
- Addendum (optional)

Further information: "Notes on reading the documentation", Page 13

Accessories

The following items are optionally available and can be ordered from HEIDENHAIN as additional accessories:

Accessories	Part number
Single-Pos stand For rigid mounting, inclination angle 20°	1197273-01
Multi-Pos holder For fastening on an arm, continuously tiltable and swivelable	1197273-02
Mounting frame For mounting to a panel	1197274-01
Cover For protection from dirt and debris	1197275-01

3.4 In case of damage in transit

- ▶ Have the shipping agent confirm the damage
- ▶ Keep the packaging materials for inspection
- ▶ Notify the sender of the damage
- ▶ Contact the distributor or machine manufacturer for replacement parts

i In case of damage in transit:

- ▶ Keep the packaging materials for inspection
- ▶ Contact HEIDENHAIN or the machine manufacturer

This applies also if damage occurred to requested replacement parts during transit.

3.5 Repackaging and storage

Repackage and store the product carefully in accordance with the conditions stated below.

Repackaging

Repackaging should correspond to the original packaging as closely as possible.

- ▶ Attach all mounting parts and dust protection caps to the product or repackage them in the same way they were originally shipped from the factory.
- ▶ Repackage the product such that it is protected from impact and vibration during transit
- ▶ Repackage the product such that it is protected from the ingress of dust or humidity
- ▶ Place all accessories that were included in the shipment in the original packaging

Further information: "Items supplied and accessories", Page 26

- ▶ Include the Addendum (if it was included in the items supplied), the Installation Instructions and the Operating Instructions

Further information: "Storage and distribution of the documentation", Page 14

i If you return the product for repair to a service agency:

- ▶ Ship the product without accessories, without measuring devices and without peripherals

Storage of the product

- ▶ Package the product as described above
- ▶ Observe the specified ambient conditions
- ▶ Inspect the product for damage after any transport or longer storage times

4

Mounting

4.1 Overview

This chapter contains all of the information necessary for mounting the product.

i The following steps are only to be performed by qualified personnel.
Further information: "Personnel qualification", Page 21

4.2 Assembly

General mounting information

The receptacle for the mounting variants is provided on the rear panel. The connection is compatible with VESA standard 100 mm x 100 mm.

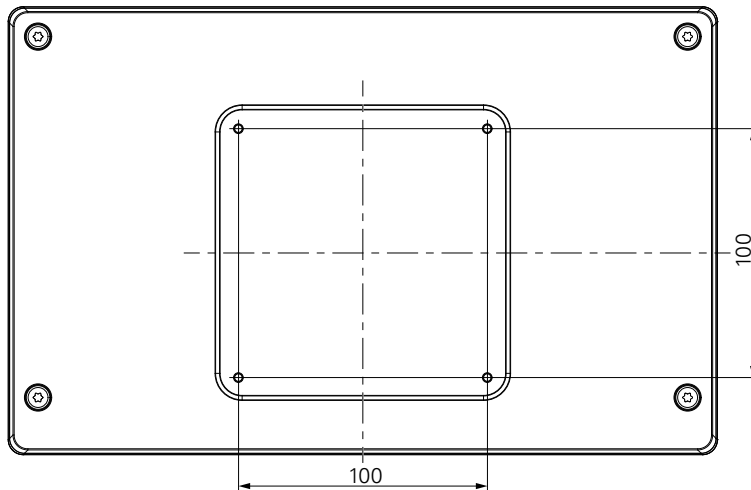

The material for attaching the mounting variants on the device is included in the accessories to the product.

You will also need the following:

- Torx T20 screwdriver
- 2.5 mm allen wrench
- 7 mm socket wrench
- Material for mounting on supporting surface

i The product must be mounted on a stand, a holder, or in a mounting frame to ensure the correct and intended operation of the product.

Routing the cables

i In the figures showing the mounting variants, you will find suggestions for routing the cables after mounting.

When mounting to a mounting variant:

- ▶ Bring the cables together
- ▶ Route the cables laterally to the connections as shown in the illustrations

4.3 Mounting on Single-Pos stand

The Single-Pos stand allows you to place the product on a surface at an inclination angle of 20° and secure the product to a surface.

Mount the stand to the upper VESA 100 tapped holes on the rear panel of the product

- ▶ Use a Torx T20 screwdriver to tighten the countersunk head screws M4 x 8 ISO 14581 included in delivery
- ▶ Comply with the permissible tightening torque of 2.6 Nm

Secure the product against movement during operation

- ▶ Attach the supplied self-adhesive rubber pads to the bottom of the product
- ▶ If you do not screw the product to a surface, attach self-adhesive rubber pads to the bottom of the stand

i Attach the rubber pads to the stand only if you do not screw the product to a surface.

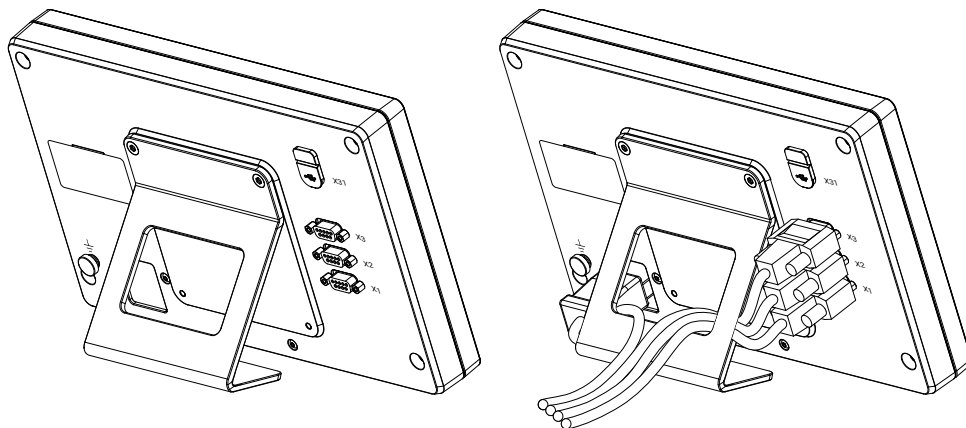

Dimensions of the Single-Pos stand

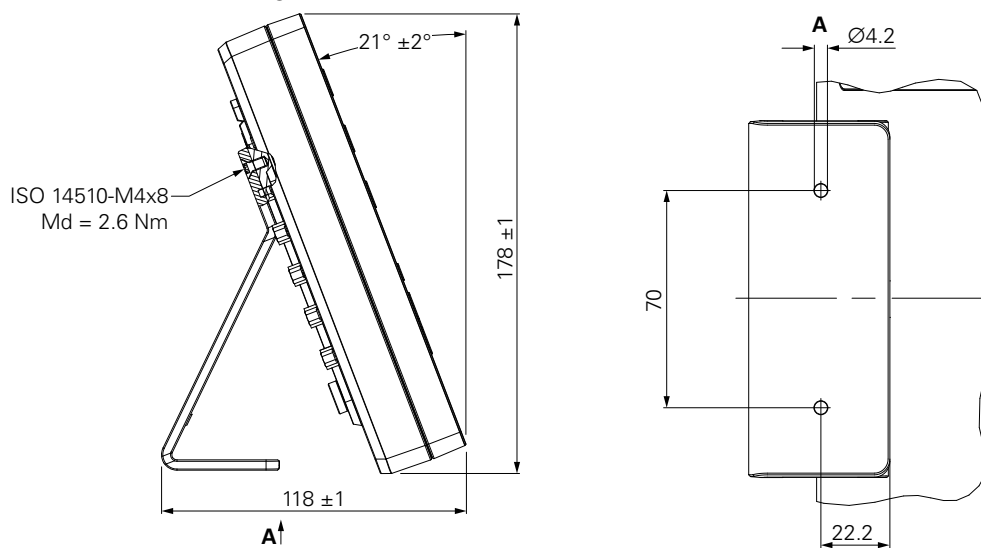

4.4 Mounting on Multi-Pos holder

Mount the holder to the bottom VESA 100 tapped holes on the rear panel of the product

- ▶ Use a Torx T20 screwdriver to tighten the countersunk head screws M4 x 10 ISO 14581 (black) included in delivery
- ▶ Comply with the permissible tightening torque of 2.5 Nm

You can tilt and swivel the holder to an angle that allows you to comfortably view the readout.

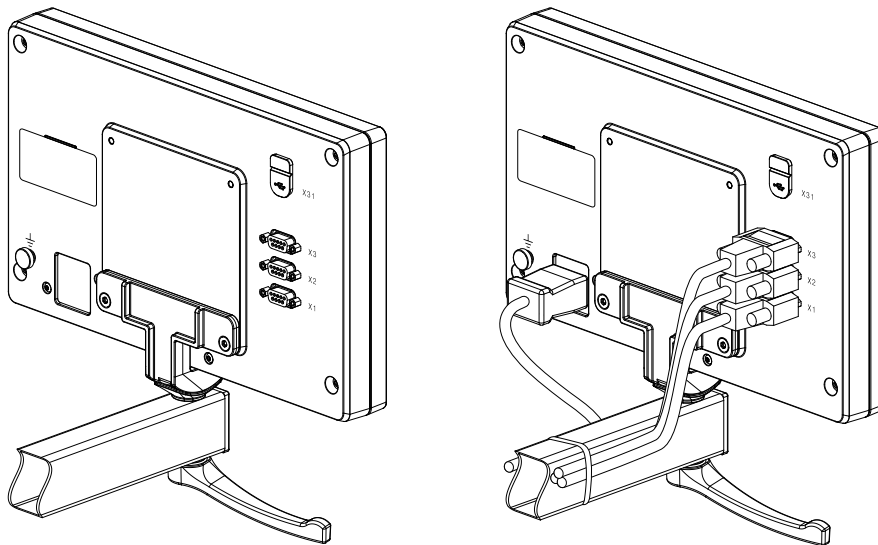

Dimensions of the Multi-Pos holder

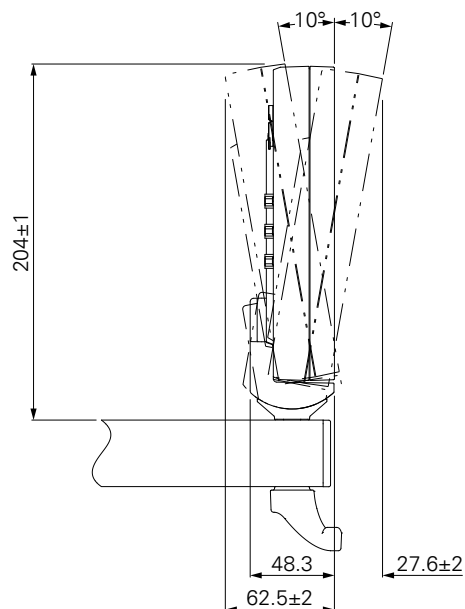

4.5 Mounting in a mounting frame

The mounting frame allows you to mount the product in a panel.

Mount the rear plate of the frame to the VESA 100 tapped holes on the rear panel of the product

- ▶ Use a 2.5 mm allen wrench to tighten the screws M4 x 6 ISO 7380 included in delivery
- ▶ Comply with the permissible tightening torque of 2.6 Nm

Mount the rear plate and the product to the front plate of the frame

- ▶ Use a 7 mm socket wrench to tighten the nuts M4 ISO 10511 included in delivery
- ▶ Comply with the permissible tightening torque of 3.5 Nm

Mount the frame and readout in the panel

- ▶ Refer to the mounting instructions provided with the mounting frame for panel cutout and mounting information

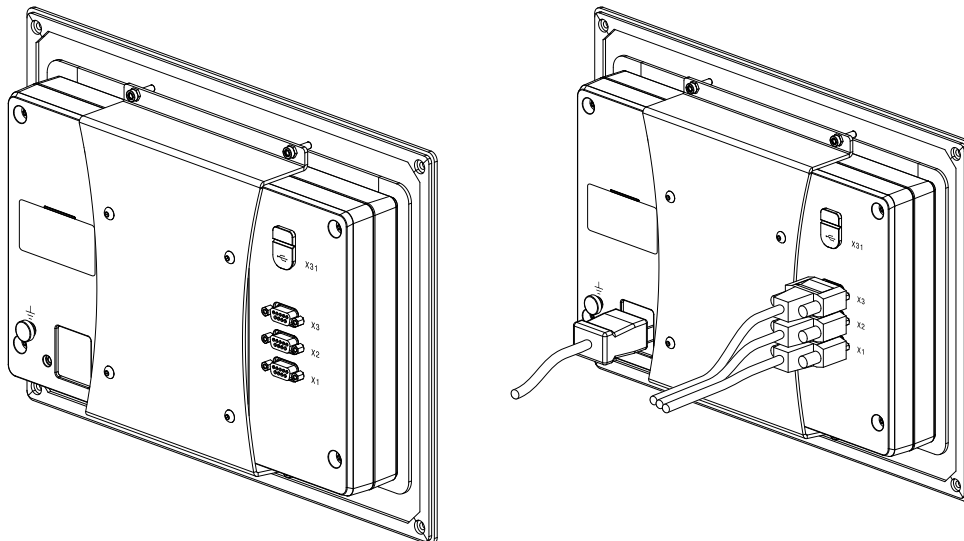

Dimensions of the mounting frame

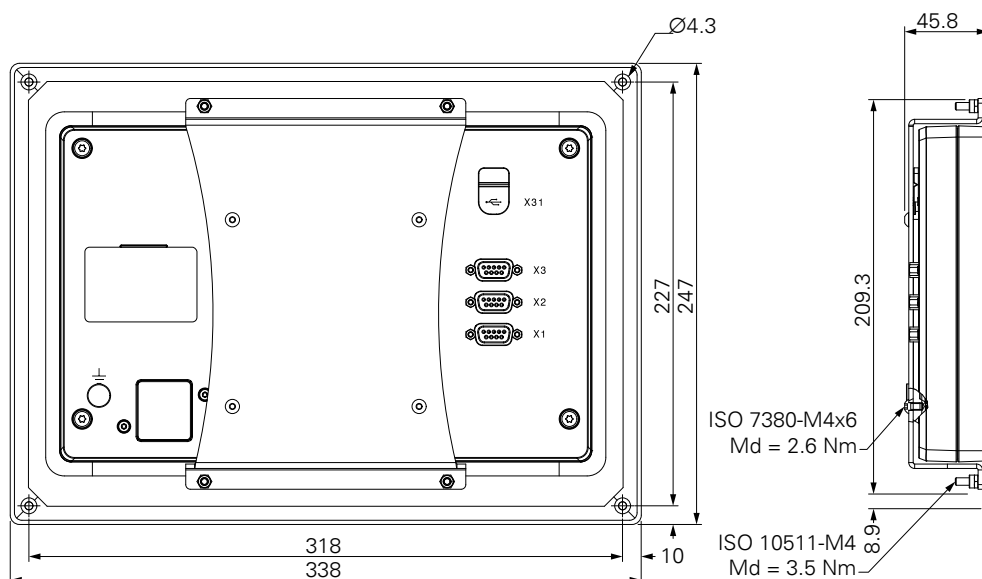

4.6 Mounting a cover

The cover protects the product from dirt and debris.

Place the cover on the product

- ▶ Place the cover over the product
- ▶ Align the cover and product on the right hand side, when viewing the front of the product

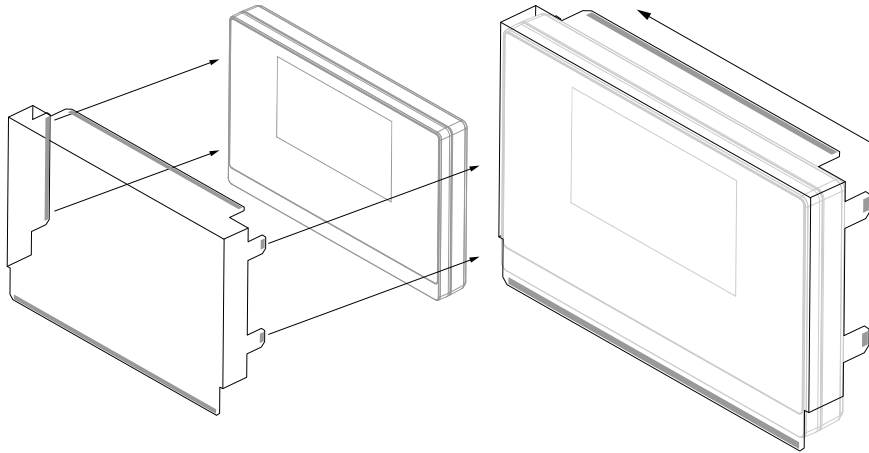

Mount the cover to the product

- ▶ Remove the adhesive strip protectors from the adhesive tabs
- ▶ Fold the adhesive tabs toward the product
- ▶ Press the adhesive tabs against the product securing the tab to the product

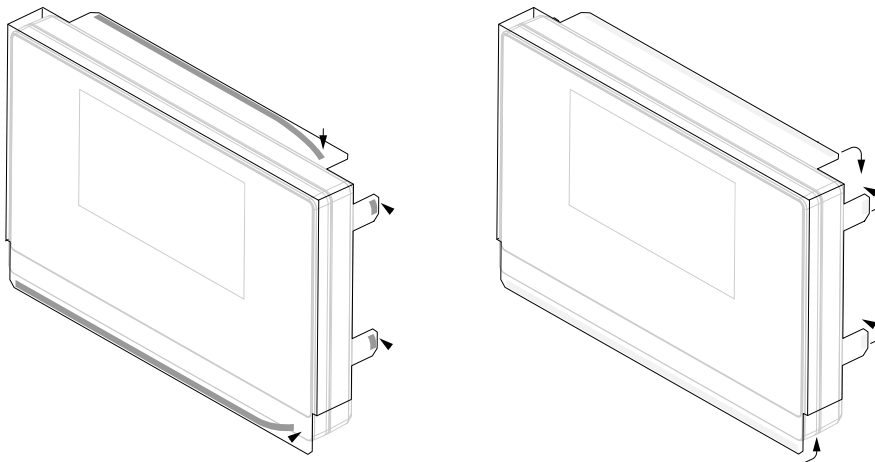

5

Installation

5.1 Overview

This chapter contains all the information necessary for installing the product.

i The following steps must be performed only by qualified personnel.

Further information: "Personnel qualification", Page 21

5.2 General information

NOTICE

Engaging and disengaging connecting elements!

Risk of damage to internal components.

- ▶ Do not engage or disengage any connecting elements while the unit is under power

NOTICE

Electrostatic discharge (ESD)!

This product contains electrostatic sensitive components that can be destroyed by electrostatic discharge (ESD).

- ▶ It is essential to observe the safety precautions for handling ESD-sensitive components
- ▶ Never touch connector pins without ensuring proper grounding
- ▶ Wear a grounded ESD wristband when handling product connections

NOTICE

Incorrect pin assignment!

This may cause product malfunctions or damage to the product.

- ▶ Only assign pins or wires that are used

5.3 Product overview

The connections on the rear panel of the device are protected by dust protection caps from contamination and damage.

NOTICE

Contamination or damage may result if the dust protection caps are missing!

This may impair the proper functioning of the contacts or destroy them.

- ▶ Remove dust protection caps only when connecting measuring devices or peripherals
- ▶ If you remove a measuring device or peripheral, reattach the dust protection cap to the connection

Rear panel without dust protection caps

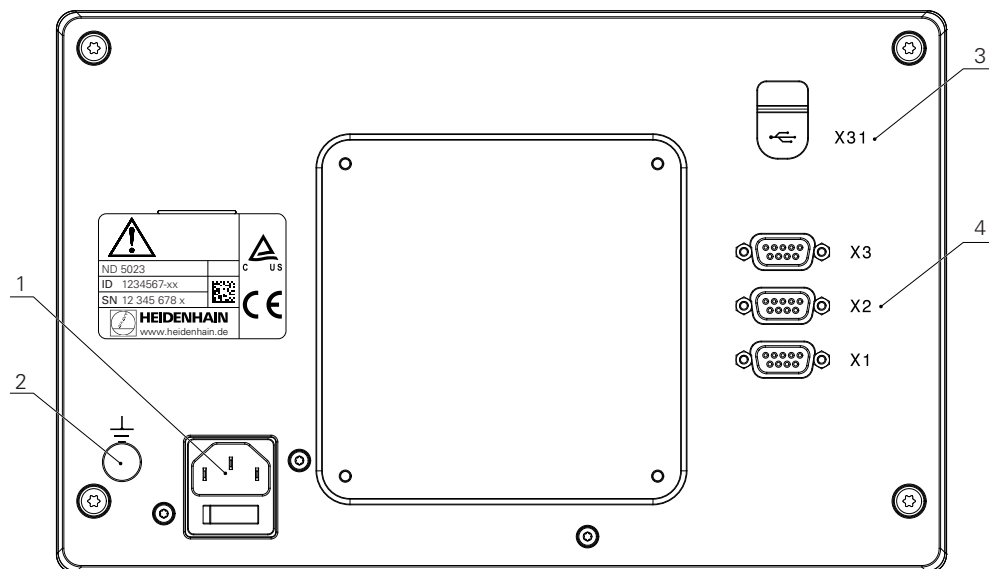

Rear panel

- 1 Power switch and power connection
- 2 Earth (ground) terminal as per IEC 60471 - 5017
- 3 **X31**: USB 2.0 Hi-Speed connection (Type C) for USB mass storage device and PC connection (beneath protective cover)
- 4 **X1 to X3**: 9-pin D-sub connections for encoders with TTL interface

5.4 Connecting an encoder

- ▶ Remove and save the dust protection caps
- ▶ Route the cables depending on the mounting variant

Further information: "Assembly", Page 30

- ▶ Connect the encoder cable tightly to the respective connection

Further information: "Product overview", Page 37

- ▶ If the cable connectors include mounting screws, do not overtighten them

Pin layout of X1 to X3

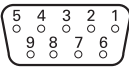
TTL								
								
1	2	3	4	5	6	7	8	9
/	U_{a1}	\overline{U}_{a1}	U_{a2}	\overline{U}_{a2}	0 V	U_p	\overline{U}_{a0}	U_{a0}

5.5 Connecting a USB device

- ▶ Open the dust protection cap
- ▶ Connect the USB device to the respective connection

Further information: "Product overview", Page 37

Pin layout of X31

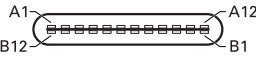
											
A1	A2	A3	A4	A5	A6	A7	A8	A9	A10	A11	A12
GND	TX1 +	TX1 -	VBUS	CC1	D +	D -	SBU1	VBUS	RX2 -	RX2 +	GND
B1	B2	B3	B4	B5	B6	B7	B8	B9	B10	B11	B12
GND	TX2 +	TX2 -	VBUS	CC2	D +	D -	SBU2	VBUS	RX1 -	RX1 +	GND

5.6 Connecting the line voltage

⚠ WARNING

Risk of electric shock!

Improper grounding of electrical devices may result in serious personal injury or death by electric shock.

- ▶ Always use 3-wire power cables
- ▶ Make sure the ground wire is correctly connected to the ground of the building's electrical installations

⚠ WARNING

Fire hazard from the use of power cables that do not meet the national requirements of the respective country in which the product is mounted.

Improper grounding of electrical devices may result in serious personal injury or death by electric shock.

- ▶ Use only a power cable that meets at least the national requirements of the respective country in which the product is mounted

- ▶ Use a power cable that meets the requirements to connect the power connection to a 3-wire grounded power outlet

Further information: "Product overview", Page 37

Pin layout of the power connection

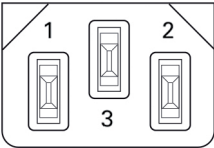
		
1	2	3
L/N	N/L	⊕

6

**Fundamentals of
positioning**

6.1 Overview

This chapter describes basic positioning information.

6.2 Datums

The workpiece drawing identifies a certain point on the workpiece (example: "a corner") as the absolute datum, and perhaps one, or more other points as relative datums.

The datum setting procedure establishes these points as the origin of the absolute, or relative coordinate systems. The workpiece, which is aligned with the machine axes, is moved to a certain position relative to the tool. The display is set to zero.

6.3 Actual position, nominal position, and Distance-To-Go

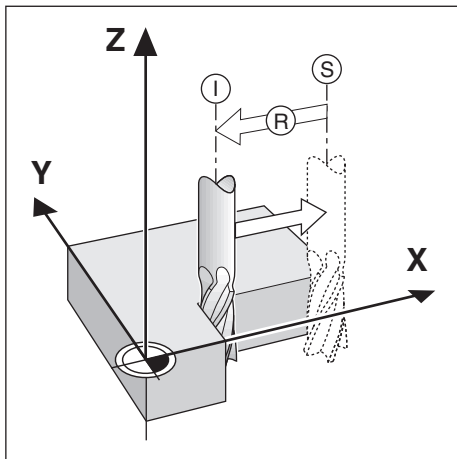

The position of the tool at any given moment is called the Actual Position **I**, while the position that the tool is to move to is called the Nominal Position **S**. The distance from the nominal position to the actual position is called the Distance-To-Go **R**.

6.4 Absolute workpiece positions

Each position on the workpiece is uniquely identified by its absolute coordinates.

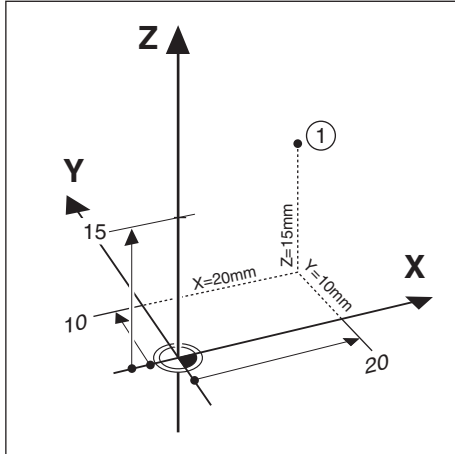

Example: Absolute coordinates of position 1:

X = 20 mm

Y = 10 mm

Z = 15 mm

If you are drilling, or milling a workpiece according to a workpiece drawing with absolute coordinates, the tool is moving to the value of the coordinates.

6.5 Incremental workpiece positions

A position can also be referenced to the preceding nominal position. In this case the relative datum is always the last nominal position. Such coordinates are referred to as Incremental Coordinates. They are also called incremental, or chain dimensions, since the positions are defined as a chain of dimensions. Incremental coordinates are designated with the prefix **I**.

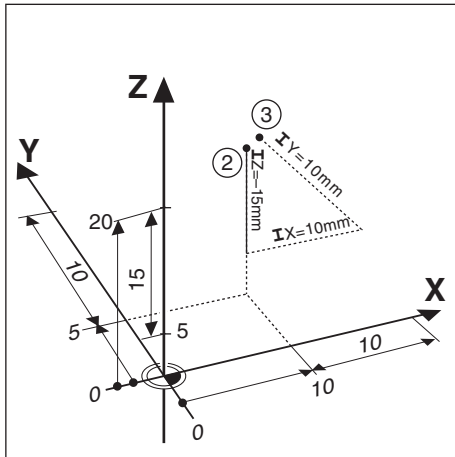

Example: Incremental coordinates of position **3** referenced to position **2**.

Absolute coordinates of position **2**:

X = 10 mm

Y = 5 mm

Z = 20 mm

Incremental coordinates of position **3**:

IX = 10 mm

IY = 10 mm

IZ = 15 mm

If you are drilling, or milling a workpiece according to a drawing with incremental coordinates, you are moving the tool by the value of the coordinates.

6.6 Zero angle reference axis

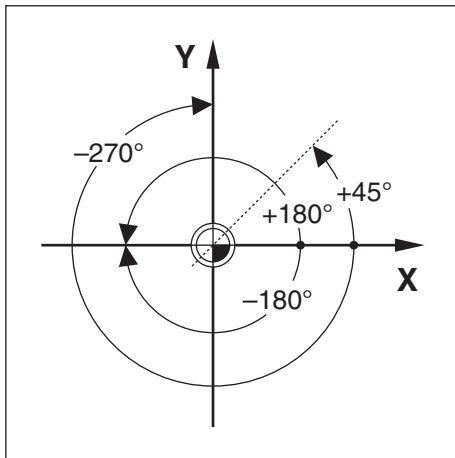

The Zero Angle Reference Axis is the 0.0° position. It is defined as one of the two axes in the plane of rotation. The following table defines the Zero Angle where the position of the angle is zero for the three possible planes of rotation.

For angular positions, the following reference axes are defined:

Plane	Zero Angle Reference Axis
XY	+X
YZ	+Y
ZX	+Z

Positive direction of rotation is counterclockwise if the working plane is viewed in the negative tool axis direction.

Example: Angle in the working plane X / Y

Plane	Zero Angle Reference Axis
$+45^\circ$... bisecting line between +X and +Y
$\pm 180^\circ$... negative X axis
-270°	... positive Y axis

6.7 Reading head position

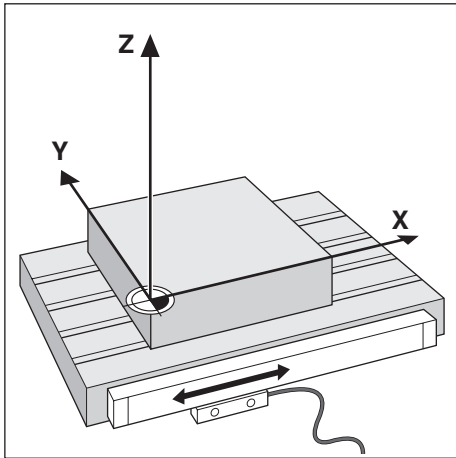

The reading head position provides feedback to the product that converts the movement of the machine axes into electrical signals. The product constantly evaluates these signals, calculates the actual positions of the machine axes, and displays the positions as a numerical value on the display.

If there is an interruption in power, the calculated position will no longer correspond to the actual position. When power is restored, you can re-establish this relationship by using the reference marks on the encoder. This product provides the Reference Mark Evaluation Feature (REF).

6.8 Encoder reference marks

Encoders normally contain one or more reference marks which the Reference Mark Evaluation feature uses to re-establish datum positions after a power interruption. There are two main options available for reference marks:

- Fixed reference marks
- Distance-coded reference marks

Fixed reference marks

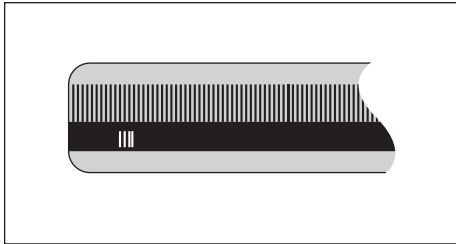

Encoders that have one or more marks on fixed intervals have to re-establish the datums correctly. It is necessary to use the same exact reference mark, during the Reference Mark Evaluation routine, that was used when the datum was first established.

Position Trac (Distance-coded reference marks)

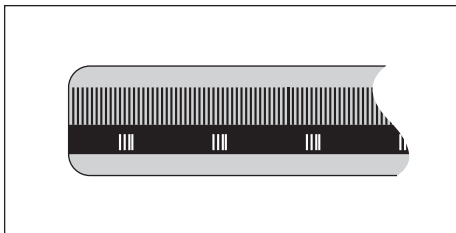

Encoders that have marks separated by a specific encryption pattern allow the product to use any two pair of marks along the length of the encoder to re-establish the prior datums. This configuration means that you only have to travel less than 20 mm anywhere along the encoder to re-establish the datums when the product is switched back on.



The established datums cannot be restored from one power cycle to the next if the reference marks were not crossed before the datums were set.

7

Basic operation

7.3 Switch-on/Switch-off

7.3.1 Switch-on



Before using the product, you need to perform the commissioning steps. Depending on the purpose of use, you may have to configure additional setup parameters.

Further information: "Commissioning", Page 65

To switch-on the product:

- ▶ Turn the power switch on
The power switch is on the rear side of the unit
- > The unit powers up. This can take a moment.
- > The first-time configuration screen will appear if this is the first time turning on the product or after resetting factory default settings
- ▶ Press the **Installation Guide** soft key to go to the **Installation Guide**
or
- ▶ Press any key to continue to the display

7.3.2 Switch-off

To switch-off the product:



- ▶ Turn the power switch off
The power switch is on the rear side of the unit
- > The unit powers down

7.4 User interface

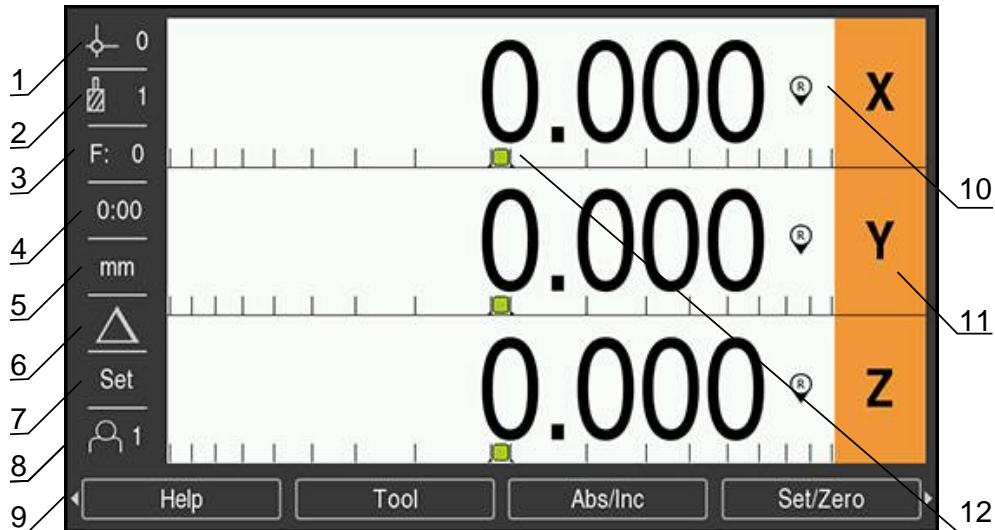
7.4.1 Display layout



- 1 Datum
- 2 Tool
- 3 Feed rate
- 4 Stopwatch
- 5 Unit of measure
- 6 Operating mode
- 7 Set/Zero
- 8 User
- 9 Soft keys
- 10 Reference mark indicator
- 11 Axis labels
- 12 Graphic positioning aid

Feature	Function
Status bar	Displays the current datum, tool, feed rate, stopwatch time, unit of measure, operating mode status, set/zero setting, and the current user
Display area	Indicates the current position of each axis. Also shows forms, fields, instruction boxes, error messages, and help topics
Axis labels	Indicates axis for corresponding axis key
Reference mark indicator	Indicates current reference mark status  Reference marks are established. A flashing indicator represents that reference mark detection is enabled, but the reference marks have not yet been established.  Reference marks are not established
Soft keys	Indicate various functions based on the current operating mode or menu
Graphic positioning aid	Indicates the Distance-To-Go

7.4.2 Soft keys

There are multiple pages of soft key functions to select when in one of the operating modes.

To navigate the soft key pages:

- ▶ Press the **left** or **right arrow** key to cursor through each page

Soft key	Function
Help	Press the Help soft key to open the operating instructions
Tool	Press the Tool soft key to open the Tool Table
Abs/Inc	Press the Abs/Inc soft key to toggle between Actual Value (Absolute) and Distance-To-Go (Incremental) modes
Set/Zero	Press the Set/Zero soft key to toggle between Set and Zero functions. Used with individual axis keys.
Datum	Press the Datum soft key to open the Datum form and set the datum for each axis
Preset	Press the Preset soft key to open the Preset form. This form is used to set a nominal position. This is a Distance-To-Go (Incremental) function.
1/2	Press the 1/2 soft key to divide the current position by two. Available in Mill application only.
Features	Press the Features soft key to select the Circle Pattern or Linear Pattern table
Rad/Dia	Press the Rad/Dia soft key to toggle between diameter and radius measurements. Available in Turn application only.
Setup	Press the Setup soft key to access the Configuration menu
Enable Ref	Press the Enable Ref soft key when you are ready to identify a reference mark
Calc	Press the Calc soft key to open the calculator
inch/mm	Press the inch/mm soft key to toggle between inch and millimeter units of measure
Disable Ref	Press the Disable Ref soft key when you want to cross over a reference mark and have the system ignore the reference mark
No Ref	Press the No Ref soft key to exit the reference mark evaluation routine and work without reference marks

7.4.3 Graphic positioning aid

When positioning to the next nominal position, the product assists you by displaying the Distance-To-Go as well as a graphic positioning aid ("traversing to zero"). A scale is shown underneath each axis you traverse to zero. The graphic positioning aid is a small square that symbolizes the axis slide.

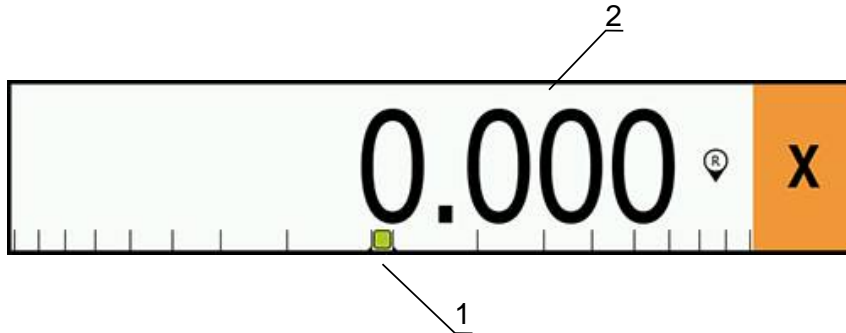

- 1 Graphic positioning aid (axis slide)
- 2 Distance-To-Go

The positioning aid moves across the scale when the axis slide is within a range of the nominal position. The default range is ± 5 mm and can be changed in the **Graphic Pos Aid** menu.

Further information: "Graphic positioning aid", Page 87

The color also changes in the following way:

Color	Meaning
Red	The axis slide is moving away from the nominal position
Green	The axis slide is moving towards the nominal position

7.4.4 Operating modes

The product has two operating modes:

- Distance-To-Go (Incremental)
- Actual Value (Absolute)

Distance-To-Go mode (Incremental)

The Distance-To-Go mode enables you to approach nominal positions by zeroing the axes and traversing to a position based on its distance from the zeroed position.

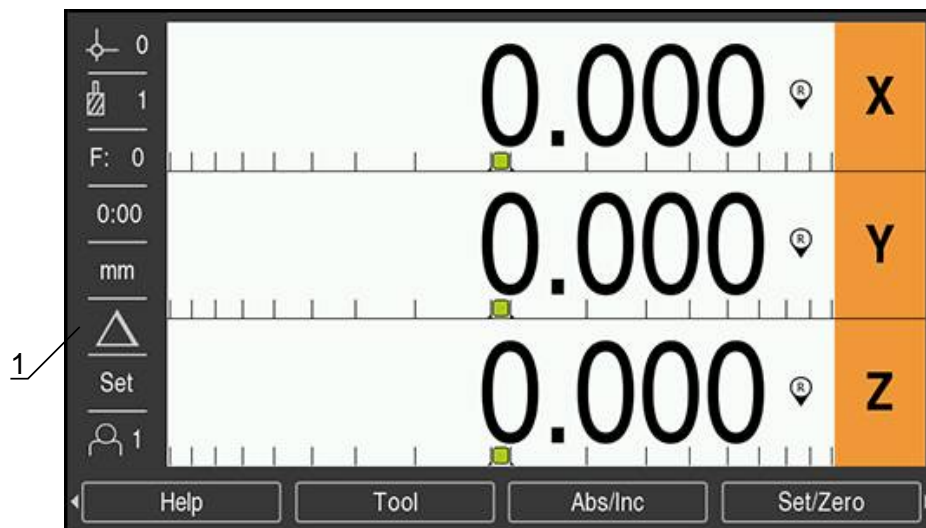

1 Distance-To-Go mode (Inc)

Actual Value mode (Absolute)

The Actual Value mode always displays the current actual position of the tool, relative to the active datum. In this mode, all moves are done by traveling until the display matches the nominal position that is required.

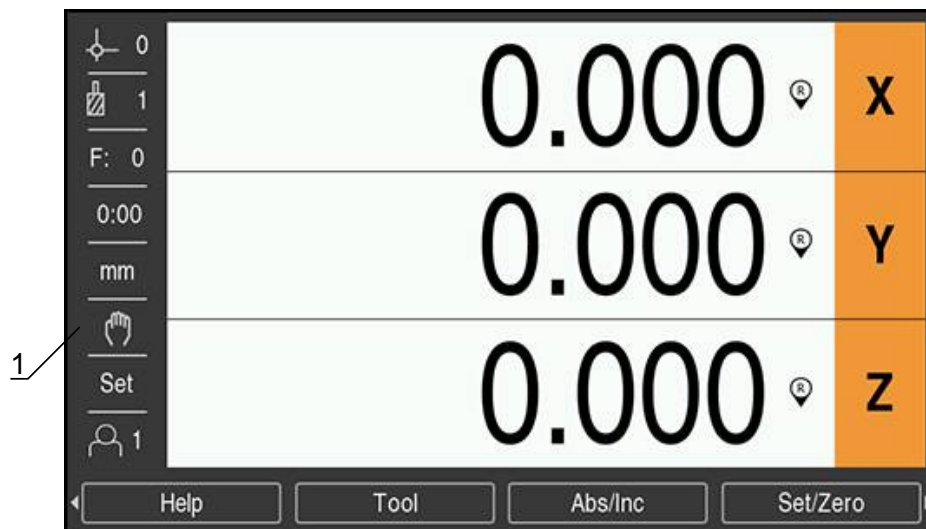

1 Actual Value mode (Abs)

Changing the operating mode

To change the operating mode:

- ▶ Press the **Abs/Inc** soft key to toggle between operating modes

7.4.5 Stopwatch

On the DRO screen the **Stopwatch** shows the minutes and seconds until 59:59 is reached, then displays hours and minutes. The **Stopwatch** shows elapsed time. The clock starts timing from 0:00.

The **Stopwatch** can also be operated from the **Job Setup** menu.

Further information: "Stopwatch", Page 87

Starting and stopping the Stopwatch

To start or stop the **Stopwatch**:

- ▶ Press the . (decimal) key on the numeric key pad to start or stop the **Stopwatch**
- > The elapsed time field in the status bar shows the total accumulated time

Resetting the Stopwatch

To reset the **Stopwatch**:

- ▶ Press the **0** (zero) key on the numeric keypad to reset the **Stopwatch** time

7.4.6 Calculator

The **Calculator** is capable of handling everything from simple arithmetic to complex trigonometry and RPM calculations.

Using the Standard/Trig Calculator

To open the **Calculator**:

- ▶ Press the **Calc** soft key
- ▶ Press the **Standard/Trig** soft key

Trig functions contain all trig operators as well as, square and square root. Whenever you are calculating the SIN, COS, or TAN of an angle, enter the angle first and then press the appropriate soft key.

When you need to enter more than one calculation into a numeric field, the calculator will perform multiplication and division before it performs addition and subtraction.

Ex. If you were to enter $3 + 1 \div 8$, the calculator will divide one by eight, then add three for an answer of 3.125.



Angle values use the current angle format selection of decimal degrees, or radians.

Using the Rpm Calculator

The **Rpm Calculator** is used to determine the **rpm** (or surface cutting speed) based on a specified tool (part, for turning applications) diameter. The values shown are only an example. Consult your tool manufacturer's manual to verify spindle speed ranges per tool.

To use the **Rpm Calculator**:

- ▶ Press the **Calc** soft key
- ▶ Press the **rpm** soft key to open the **Rpm Calculator** form

The **Rpm Calculator** requires a tool **Diameter** for **Mill** applications. The **Diameter** value will default to the current tool's **Diameter**. If there is no last value entered in this power cycle, the default value is 0.

- ▶ Use the numeric key pad to enter a **Diameter** value
- ▶ If a **Surface Speed** value is required, enter the value using the numeric key pad

When a **Surface Speed** value is entered, the associated **rpm** value will be calculated.

- ▶ Press the **Units** soft key to show the **Units** as inch or mm
- ▶ Press the **C** key to close the **Rpm Calculator** and save the current data

7.4.7 Help

Integrated operating instructions provide context-sensitive **Help** when operating the product.

i The operating instructions may take a moment to load the first time they are opened:

- After uploading a new operating instructions file
- After changing the user interface language

The message **Loading file. Please wait ...** will display while the operating instructions load.

To open the operating instructions:

- ▶ Press the **Help** soft key
- The operating instructions will open to the section that covers the current feature or function being used on the product.

The following key functions are available in **Help**:

Key	Function
First axis	Press the First axis key to open the table of contents
Up arrow	Press the Up arrow key to navigate back in the operating instructions
Down arrow	Press the Down arrow key to navigate forward in the operating instructions
Right arrow	Press the Right arrow key to highlight the first link on a page If a link is already highlighted: Press the Right arrow key to highlight the next link on a page
Left arrow	Press the Left arrow key to highlight the last link on a page If a link is already highlighted: Press the Left arrow key to highlight the previous link on a page
enter	Press the enter key to navigate to a link that is highlighted
C	Press the C key to remove a highlight from a link If no links are highlighted: Press the C key to exit Help

7.4.8 Data input forms

Information required for various operational functions and setup parameters are entered through data input forms. These forms will appear after selecting features that require additional information. Each form provides specific fields for entering the required information.

Confirming changes

To confirm changes:

- ▶ Press the **enter** key to apply the selected parameter changes

Canceling changes

To cancel changes:

- ▶ Press the **C** key to return to the previous screen without saving changes

7.4.9 Reference mark evaluation

The Reference Mark Evaluation feature automatically re-establishes the relationship between axis slide positions and display values that was last defined by setting the datum.

The reference mark indicator will flash for each axis with an encoder that has reference marks. The indicator will stop flashing after crossing over the reference marks.

Activating reference marks



1 Reference marks enabled

To activate reference marks:

- ▶ Cross over the reference marks for each axis to activate the reference
- > After a successful reference mark evaluation, the indicator will stop flashing

Working without reference marks

The product can also be used without crossing over the reference marks.



1 Reference marks disabled

To work without reference marks:

- ▶ Press the **No Ref** soft key to exit the reference mark evaluation routine, and continue
- > After disabling reference marks the indicator will have a forward slash through it, signifying that the reference marks have been disabled

Re-enabling reference marks

Reference marks can be enabled any time after they have been disabled

To re-enable reference marks:

- ▶ Press the **Enable Ref** soft key to activate the reference mark evaluation routine

i If an encoder is setup without reference marks the reference indicator will not be displayed. A datum set from the axis will be lost once power is turned off.

7.4.10 Selecting a specific reference mark

The product provides the ability to select a specific reference mark on an encoder. This is important when using encoders with fixed reference marks.

To select a specific reference mark:

- ▶ Press the **Disable Ref** soft key
- > The evaluation routine is paused. Any reference marks that are crossed during encoder movement are ignored.
- ▶ Cross over undesired reference marks
- ▶ Press the **Enable Ref** soft key
- > The next reference mark that is crossed will be selected.
- ▶ Cross the desired reference mark
- ▶ Repeat this process for all desired reference marks
- ▶ Press the **No Ref** soft key to cancel out of routine after all desired axes are established
- > Only the axes that are needed require crossing over the reference marks. If all reference marks have been found the product will return to the DRO display screen automatically.



The product does not store datum points if the reference marks are not crossed. The relationship between axis slide positions and display values will not be re-established after a power interruption or switch-off.

7.4.11 Error messages

If an error occurs while working with the product, a message will appear on the display, and provide an explanation of what caused the error.

Further information: "What to do if...", Page 159

To clear an error message:

- ▶ Press the **C** key
- > The error message will be cleared and normal operation can continue

7.4.12 Setup menus

The product has two menus for setting up operating parameters:

- **Installation Setup**
- **Job Setup**

Installation Setup

The **Installation Setup** menu is used to establish encoder, display, and communication parameters.

Further information: "Installation Setup", Page 68

To access the **Installation Setup** menu:

- ▶ Press the **Setup** soft key
- ▶ Select **Installation Setup**
- > The **Installation Setup** options are displayed

Job Setup

The **Job Setup** menu is used to accommodate specific machining requirements for each job.

Further information: "Job Setup", Page 85

To access the **Job Setup** menu:

- ▶ Press the **Setup** soft key
- ▶ Select **Job Setup**
- > The **Job Setup** options are displayed

7.5 User Management

The **User Management** menu provides a **Supervisor Login** and **User Job Settings** management.

7.5.1 Supervisor Login

The **Supervisor Login** allows you to manage users in the **User Management** menu and to modify configuration parameters in the **Installation Setup** menu.

Further information: "Installation Setup", Page 68

To login as a supervisor:

- ▶ Press the **Setup** soft key
- ▶ Open in the sequence:
 - **User Management**
 - **Supervisor Login**
- ▶ Enter the **Passcode** '95148'
- ▶ Press the **enter** key

7.5.2 User Job Settings

When **Job Setup** parameters are configured they are automatically saved under the selected user.

Further information: "Job Setup", Page 85

Selecting a User

To select a **User**:

- ▶ Press the **Setup** soft key
- ▶ Open in the sequence:
 - **User Management**
 - **User Job Settings**
- ▶ Use the **up** and **down arrow** keys to highlight **Load** for the desired **User**
- ▶ Press the **enter** key
- > The selected **User** is displayed in the status bar
- ▶ Press the **C** key twice to return to the DRO screen

Saving User Job Settings

To save **User Job Settings**:

- ▶ Select a **User**
- ▶ Configure **Job Setup** parameters for the user
Further information: "Job Setup", Page 85
- The **Job Setup** parameters are automatically saved for the selected user.
- ▶ Select another **User** and repeat these steps until all of your required users have been setup

Supervisor level User Job Settings

A supervisor can create a default set of **Job Setup** parameters and use the settings to reset user configurations.

Further information: "Supervisor Login", Page 62

Creating a default set of Job Setup parameters

To create default **User Job Settings**:

- ▶ Select **User-0**
- ▶ Configure **Job Setup** parameters for **User-0**
Further information: "Job Setup", Page 85
- The **Job Setup** parameters are automatically saved for the user

Resetting User Job Settings

To reset an individual **User**:

- ▶ Select a **User**
- ▶ Press the **right arrow** key to open the drop-down menu
- ▶ Press the **down arrow** key to highlight **Reset**
- ▶ Press the **enter** key to select **Reset**
- ▶ Press the **enter** key to reset the **Job Setup** parameters for the selected user to the **User-0** settings

To reset **All Users**:

- ▶ Select **All Users**
- ▶ Press the **enter** key to reset the **Job Setup** parameters for all users to the **User-0** settings

8

Commissioning

8.1 Overview

i Make sure that you have read and understood the "Basic Operation" chapter before performing the activities described in this section.
Further information: "Basic operation", Page 49

i The following steps are only to be performed by qualified personnel.
Further information: "Personnel qualification", Page 21

During the commissioning process the product is configured for use. Parameters that are changed during the commissioning process can be reset to the factory defaults.

Further information: "Factory defaults", Page 79

Backing up the configuration

Configuration data can be backed up after commissioning. The configuration data can be reused for equivalent products.

Further information: "Configuration parameters", Page 68

8.2 Installation Guide

An **Installation Guide** is provided the first time you switch-on the product. This guide will step you through common commissioning parameters.

Information about specific parameters included in the **Installation Guide** can be found in the Settings section of these instructions.

Further information: "Settings", Page 147



The **Installation Guide** provides configuration options for the following parameters:

- **Language**
- **Encoder Setup**
- **Display Configuration**
- **Readout Settings**
 - **Application**
 - **Number of Axes**
- **Encoder Type**
- **Encoder Resolution**
- **Reference Mark**
- **Count Direction**
- **Error Monitor**
- **Display Resolution**
- **Label**
- **Display Color Scheme**
 - **Color Mode**

Opening the Installation Guide

To access the **Installation Guide** from the first-time startup screen:

- ▶ Press the **Installation Guide** soft key
- > The **Installation Guide** opens

Navigating the Installation Guide

- ▶ Press the **right arrow** key to open a parameter drop-down menu
- ▶ Press the **up** or **down arrow** key to highlight a parameter option
- ▶ Press the **enter** key to select an option
- ▶ Press the **Next** soft key to advance to the next parameter
- or
- ▶ Press the **Previous** soft key to go back to a previous parameter
- ▶ Repeat these steps until all parameters have been set

8.3 Installation Setup

The **Installation Setup** menu is used to establish encoder and display parameters.

Further information: "Settings", Page 147

i **Installation Setup** parameters must be configured only by qualified personnel.

Further information: "Personnel qualification", Page 21

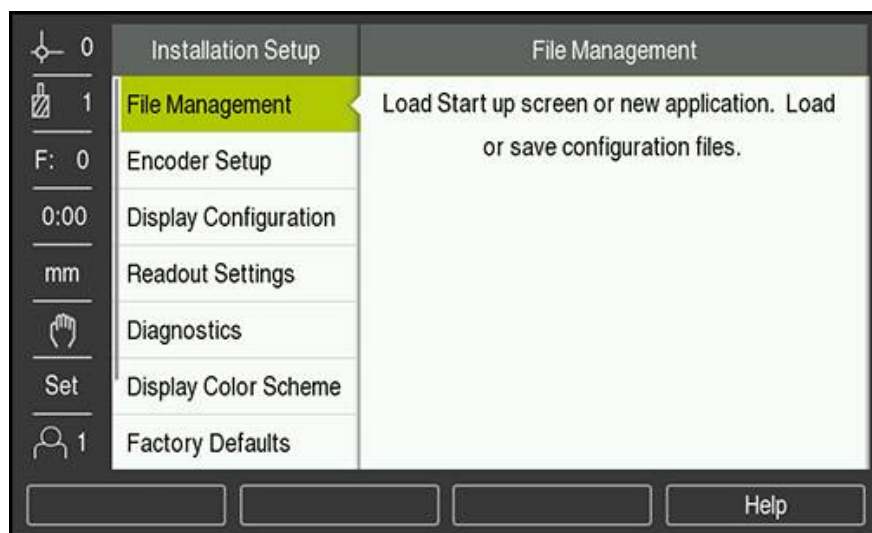

To access the Installation Setup menu:

- ▶ Press the **Setup** soft key
- ▶ Use the **up** or **down arrow** key to highlight **Installation Setup**
- ▶ Press the **right arrow** key
- > The **Installation Setup** menu is displayed

8.3.1 File management

Configuration parameters

The configuration of the product can be backed up as a file to make it available after a reset to the factory default settings or for installation on multiple products. A file with the following properties needs to be stored on the product for this purpose:

- File format: DAT
- File name: config.dat

Importing configuration parameters

To import configuration parameters:

- ▶ Insert a USB memory device containing the .dat file into the USB connection
- ▶ Press the **Setup** soft key
- ▶ Open in the sequence
 - **Installation Setup**
 - **File Management**
 - **Configuration Parameters**
- ▶ Press the **Import** soft key
- ▶ Press the **enter** key to initiate importing the configuration parameters
- > A pop-up warning informs you that the current parameter settings will be overwritten
- ▶ Press the **enter** key to import the configuration parameters and return to the **File Management** menu
 - or
 - ▶ Press the **C** key to cancel

Exporting configuration parameters

To export configuration parameters:

- ▶ Insert a USB memory device into the USB connection
- ▶ Press the **Setup** soft key
- ▶ Open in the sequence
 - **Installation Setup**
 - **File Management**
 - **Configuration Parameters**
- ▶ Press the **Export** soft key
- ▶ Press the **enter** key to initiate exporting the configuration parameters
- > A pop-up warning informs you that the current parameter settings will be exported to the attached USB memory device

 The config.dat file on the USB memory device will be overwritten.

- ▶ Press the **enter** key to export the configuration parameters and return to the **File Management** menu
 - or
 - ▶ Press the **C** key to cancel

Segmented LEC Table

- File format: DAT
- File name: slsec_1.dat (axis 1), slsec_2.dat (axis 2), slsec_3.dat (axis 3)

Importing a Segmented LEC Table

To import a **Segmented LEC Table**:

- ▶ Insert a USB memory device containing the .dat file into the USB connection
- ▶ Press the **Setup** soft key
- ▶ Open in the sequence
 - **Installation Setup**
 - **File Management**
 - **Segmented LEC Table**
- ▶ Press the **Import** soft key
- ▶ Press the **enter** key to initiate importing the table
- > A pop-up warning informs you that the current table will be overwritten
- ▶ Press the **enter** key to import the table and return to the **File Management** menu
or
- ▶ Press the **C** key to cancel

Exporting a Segmented LEC Table

To export a **Segmented LEC Table**:

- ▶ Insert a USB memory device into the USB connection
- ▶ Press the **Setup** soft key
- ▶ Open in the sequence
 - **Installation Setup**
 - **File Management**
 - **Segmented LEC Table**
- ▶ Press the **Export** soft key
- ▶ Press the **enter** key to initiate exporting the table
- > A pop-up warning informs you that the current table will be exported to the attached USB memory device
- ▶ Press the **enter** key to export the table and return to the **File Management** menu
or
- ▶ Press the **C** key to cancel

Tool Table

- File format: DAT
- File name: tool_mill.dat (**Mill** application), tool_turn.dat (**Turn** application)

Importing a Tool Table

To import a **Tool Table**:

- ▶ Insert a USB memory device containing the .dat file into the USB connection
- ▶ Press the **Setup** soft key
- ▶ Open in the sequence
 - **Installation Setup**
 - **File Management**
 - **Tool Table**
- ▶ Press the **Import** soft key
- ▶ Press the **enter** key to initiate importing the table
- > A pop-up warning informs you that the current table will be overwritten
- ▶ Press the **enter** key to import the table and return to the **File Management** menu
or
- ▶ Press the **C** key to cancel

Exporting a Tool Table

To export a **Tool Table**:

- ▶ Insert a USB memory device into the USB connection
- ▶ Press the **Setup** soft key
- ▶ Open in the sequence
 - **Installation Setup**
 - **File Management**
 - **Tool Table**
- ▶ Press the **Export** soft key
- ▶ Press the **enter** key to initiate exporting the table
- ▶ A pop-up warning informs you that the current table will be exported to the attached USB memory device
- ▶ Press the **enter** key to export the table and return to the **File Management** menu
or
- ▶ Press the **C** key to cancel

Operating Instructions

The product's **Operating Instructions** can be loaded onto the product and viewed using the **Help** function.

Operating Instructions can be loaded to the product in multiple languages. The product will look for the operating instructions in the **Language** selected in the **Job Setup** menu when loading the file from a USB memory device.



An error will be displayed if the operating instructions are not found on the USB memory device in the selected **Language**.

The **Operating Instructions** can be downloaded from the download area at www.heidenhain.com.

A file with the following properties needs to be loaded onto the product:

- File format: mPub
 - File name: ND5000_xx.mpub¹⁾
- ¹⁾ xx: corresponds to the ISO 639-1 two-letter code

To load the **Operating Instructions**:

- ▶ Select the desired **Language** if it is different than the currently selected language
Further information: "Language", Page 90
- ▶ Insert a USB memory device containing the **Operating Instructions** mPub file into the USB connection
- ▶ Press the **Setup** soft key
- ▶ Open in the sequence
 - **Installation Setup**
 - **File Management**
 - **Operating Instructions**
- ▶ Press the **Load** soft key
- ▶ Press the **enter** key to initiate loading the **Operating Instructions**
- ▶ A pop-up warning informs you that the **Operating Instructions** will be loaded
- ▶ Press the **enter** key to load the **Operating Instructions**
or
- ▶ Press the **C** key to cancel

Power-up Screen

You can define an OEM-specific **Power-up Screen**, e.g. the company name or logo, which will be displayed when the product is switched on. An image file with the following properties needs to be stored on the product for this purpose:

- File format: 24-Bit Bitmap
- Image size: 800 x 480 px
- File name: OEM_SplashScreen.bmp

Importing a power-up screen

To import a power-up screen:

- ▶ Connect a USB mass storage device containing the OEM_SplashScreen.bmp file to the USB port of the product
- ▶ Press the **Setup** soft key
- ▶ Open in the sequence
 - **Installation Setup**
 - **File Management**
 - **Power-up Screen**
- ▶ Press the **Import** soft key
- ▶ Press the **enter** key to initiate loading the power-up screen
- > A pop-up warning informs you that the power-up screen will be imported
- ▶ Press the **enter** key to import the power-up screen and return to the **File Management** menu
- or
- ▶ Press the **C** key to cancel

Exporting a power-up screen

To export a power-up screen:

- ▶ Press the **Setup** soft key
- ▶ Open in the sequence
 - **Installation Setup**
 - **File Management**
 - **Power-up Screen**
- ▶ Press the **Export** soft key
- ▶ Press the **enter** key to initiate exporting the power-up screen
- > A pop-up warning informs you that the current power-up screen will be exported to the attached USB memory device



The OEM_SplashScreen.bmp file on the USB memory device will be overwritten.

- ▶ Press the **enter** key to export the power-up screen and return to the **File Management** menu
- or
- ▶ Press the **C** key to cancel

Service File

The product saves event data that may be used for analysis at a later time. You may be asked to provide this data, by exporting a **Service File**, in the event that your product requires service.

Exporting a Service File

To export a **Service File**:

- ▶ Press the **Setup** soft key
- ▶ Open in the sequence
 - **Installation Setup**
 - **File Management**
 - **Service File**
- ▶ Press the **Export** soft key
- ▶ Press the **enter** key to initiate exporting the file
- ▶ A pop-up warning informs you that the file will be written to the USB mass storage device
- ▶ Press the **enter** key to export the file and return to the **File Management** menu
or
- ▶ Press the **C** key to cancel

Clearing the Service File data

HEIDENHAIN recommends maintaining the maximum amount of free space available in the internal memory, by clearing the saved data, after exporting a **Service File**.

To clear the service file data:

- ▶ Press the **Setup** soft key
- ▶ Open in the sequence
 - **Installation Setup**
 - **File Management**
 - **Service File**
- ▶ Press the **Clear** soft key
- ▶ Press the **enter** key to initiate clearing the history
- ▶ A pop-up warning informs you that the history will be lost
- ▶ Press the **enter** key to clear the data and return to the **File Management** menu
or
- ▶ Press the **C** key to cancel

Product Software

To install a **Product Software** update:

- ▶ Insert a USB memory device containing the **Product Software** file into the USB connection
- ▶ Press the **Setup** soft key
- ▶ Open in the sequence
 - **Installation Setup**
 - **File Management**
 - **Product Software**
- ▶ Press the **Install** soft key
- ▶ Press the **enter** key to initiate installing the software update
- > A pop-up warning informs you that the software update will be installed
- ▶ Press the **enter** key to install the software update
- > The product will restart
 - or
- ▶ Press the **C** key to cancel

8.3.2 Encoder Setup

Encoder Setup parameters are used to configure each encoder input.

i The adjustment procedure is the same for each axis. The following section describes the configuration of one axis. Repeat the procedure for each axis.

To set up an encoder:

- ▶ Press the **Setup** soft key
- ▶ Open in the sequence
 - **Installation Setup**
 - **Encoder Setup**
- ▶ Select the encoder to set up:
 - **X1**
 - **X2**
 - **X3**
- > The **Encoder Setup** parameters are displayed for the selected axis
- ▶ Select the **Encoder Type**:
 - **Linear**
 - **Rotary**
 - **Rotary (Linear)**: a rotary encoder connected to a leadscrew
- ▶ Press the **µm/inch** soft key to select the desired **Resolution** unit of measure
 - **µm**
 - **inch**
- ▶ Select the desired **Resolution**
- or
- ▶ Enter the desired **Resolution** with the keypad

i **The encoder resolution can be calculated with the formula:**
 Grating period / Interpolation / 4 = Resolution (µm)
 (e.g., 20 / 10 / 4 = 0.5 µm)

- ▶ Press the **enter** key to confirm the selection
- ▶ Select the desired **Reference Mark** type:
 - **None**: no reference signal
 - **Single**: single reference mark
 - **Coded / 1000**: a coded encoder with 1000 reference mark spacing
 - **Coded / 2000**: a coded encoder with 2000 reference mark spacing
 - **Position Trac**: an encoder with the Position-Trac feature
 - **P-Trac (ENC 250)**: an ENC 250 encoder with the Position-Trac feature
- ▶ Press the **enter** key to confirm the selection
- ▶ Select the desired **Count Direction**:
 - **Negative**
 - **Positive**

When the encoder's count direction matches the operators count direction, select **Positive**. When they do not match, select **Negative**.

i The **Count Direction** can also be established by moving the axis in the positive direction.

- ▶ Press the **enter** key to confirm the selection
- ▶ Select **On** or **Off** in the **Error Monitor** parameter to enable or disable monitoring of counting errors
- ▶ Press the **enter** key to confirm the selection
- ▶ Press the **enter** key to save the **Encoder Setup** parameter changes and return to the **Installation Setup** menu
 - or
- ▶ Press the **C** key to cancel

8.3.3 Display Configuration

Display Configuration parameters are used to configure the way axes information is shown on the display.

i The adjustment procedure is the same for each axis display. The following section describes the configuration of one axis display. Repeat the procedure for each axis display.

To configure an axis display:

- ▶ Press the **Setup** soft key
- ▶ Open in the sequence
 - **Installation Setup**
 - **Display Configuration**
- ▶ Select the axis display to set up:
 - **Display 1**
 - **Display 2**
 - **Display 3**
- ▶ The **Display Configuration** parameters are displayed for the selected axis display
- ▶ Select the desired **Display Resolution**

Display Resolution options vary based on the encoders connected to the product.
- ▶ Press the **enter** key to confirm the selection
- ▶ Select a **Label** for the axis display or **Off** to turn off the selected axis display:

■ Off	■ A
■ X	■ B
■ Y	■ C
■ Z	■ S
■ U	
■ V	
■ W	
- ▶ Press the **enter** key to confirm the selection
- ▶ Select **Off** or **On** to enable or disable a **Subscript** zero being displayed after the axis label
- ▶ Press the **enter** key to confirm the selection
- ▶ Select the desired input for the axis display in the **Input 1** parameter:
 - **X1**
 - **X2**
 - **X3**
- ▶ Press the **enter** key to confirm the selection

- ▶ Select **+** or **-** in the **Couple Operation** parameter to couple a second input with the first:
 - **+**
 - **-**
 - **Off**
- ▶ Press the **enter** key to confirm the selection
- ▶ Select the desired input to couple with **Input 1** in the **Input 2** parameter:
 - **Not Defined**
 - **X1**
 - **X2**
 - **X3**
- ▶ Press the **enter** key to confirm the selection
- ▶ Press the **enter** key to save the **Display Configuration** parameter changes and return to the **Installation Setup** menu

or
- ▶ Press the **C** key to cancel

8.3.4 Readout Settings

Readout Settings parameters are used to set **Application**, axes, and **Position Recall** requirements.

To configure the readout:

- ▶ Press the **Setup** soft key
- ▶ Open in the sequence
 - **Installation Setup**
 - **Readout Settings**
- ▶ Select the **Application**
 - **Mill**
 - **Turn**
- ▶ Select the **Number of Axes**:
 - **1**
 - **2**
 - **3**
- ▶ Press the **enter** key to confirm the selection
- ▶ Select **On** or **Off** to enable or disable **Position Recall**

Position Recall will store the last position of each axis when power was turned off, and then redisplay that position once power is turned back on.



Any movement that occurs while power is off will be lost. Whenever power has been off it is recommended to re-establish workpiece datums using the reference mark evaluation procedure.

Further information: "Reference mark evaluation", Page 59

- ▶ Press the **enter** key to confirm the selection
- ▶ Press the **enter** key to save the **Readout Settings** parameter changes and return to the **Installation Setup** menu

or
- ▶ Press the **C** key to cancel

8.3.5 Diagnostics

The **Diagnostics** feature provides a way to test the keypad and display.

- ▶ Press the **Setup** soft key
- ▶ Open in the sequence
 - **Installation Setup**
 - **Diagnostics**

Keypad Test

An image of the keypad provides an indication when a key is pressed and released.

To test the keypad:

- ▶ Press each key to test
- ▶ A key that is operating properly will turn green in the **Diagnostics** screen when pressed on the keypad, and change to gray when released.
- ▶ Press the **C** key two times to exit the keypad test

Display Test

To test the display:

- ▶ Press the **enter** key to cycle through the available colors

8.3.6 Display Color Scheme

Display Color Scheme parameters are used to set the **Color Mode** of the product. Select the **Color Mode** that makes the display easiest to view in your workspace lighting conditions.

To select a color scheme:

- ▶ Press the **Setup** soft key
 - ▶ Open in the sequence
 - **Installation Setup**
 - **Display Color Scheme**
 - ▶ Select the **Color Mode**:
 - **Day**: the color scheme is set to **Day** and cannot be selected by the user
 - **Night**: the color scheme is set to **Night** and cannot be selected by the user
 - **User Selectable**: the color mode can be selected by the user from the **Job Setup** menu
 - ▶ Press the **enter** key to confirm the selection
 - ▶ Press the **enter** key to save the **Display Color Scheme** parameter changes and return to the **Installation Setup** menu
- or
- ▶ Press the **C** key to cancel

8.3.7 Factory defaults

Parameter changes made in the **Job Setup** and **Installation Setup** menus can be reset to the factory default settings. All parameters will be reset.

Further information: "Settings", Page 147

To reset parameters to factory default settings:

- ▶ Press the **Setup** soft key
- ▶ Open in the sequence
 - **Installation Setup**
 - **Factory Defaults**
 - **Reset Settings**
- ▶ Press the **Yes/No** soft key and select **Yes**
- ▶ Press the **enter** key to initiate resetting the product to the factory default settings
- ▶ A warning window will appear to confirm the reset
- ▶ Press the **enter** key to reset parameters to the factory default settings
The product will restart.
- or
- ▶ Press the **C** key to cancel the reset

8.3.8 Error Compensation

The distance a cutting tool travels, measured by an encoder, can in certain cases differ from the actual tool travel. This error can occur due to ball screw pitch error, or deflection and tilting of axes. Errors can be determined with a reference measurement system, such as gauge blocks.

The product provides the ability to compensate for linear errors, and each axis can be programmed separately with the appropriate compensation.

 Error compensation is only available when using linear encoders.

 The adjustment procedure is the same for each axis. The following section describes the configuration of one axis. Repeat the procedure for each axis.

Configuring Linear Error Compensation

Linear Error Compensation (LEC) can be applied, if the results of a comparison with a reference standard show a linear deviation over the whole measuring length. In this case the error can be compensated by the calculation of a single correction factor.

To calculate the correction factor use this formula:

Correction factor **LEC = ((S – M) / M) x 10⁶ ppm** with:

S = measured length with a reference standard

M = measured length with device at axis

Example:

If the length of the standard you used is 500 mm, and the measured length along the X-axis is 499.95, then the LEC for the X-axis is 100 parts per million (ppm).

LEC = ((500 – 499.95) / 499.95) x 10⁶ ppm = 100 ppm (rounded to the nearest whole number).

To configure LEC:

- ▶ Press the **Setup** soft key
 - ▶ Open in the sequence
 - **Installation Setup**
 - **Error Compensation**
 - ▶ Select the input to configure:
 - **X1**
 - **X2**
 - **X3**
 - ▶ Enter the compensation factor using the numeric keypad
 - ▶ Repeat these steps for each axis you want to configure
 - ▶ Press the **enter** key to save the **Error Compensation** parameter changes and return to the **Installation Setup** menu
- or
- ▶ Press the **C** key to cancel

Configuring LEC automatically

The correction factor may be calculated automatically using a standard gauge block.

To configure LEC automatically:

- ▶ Press the **Setup** soft key
- ▶ Open in the sequence
 - **Installation Setup**
 - **Error Compensation**
- ▶ Select the input to configure:
 - **X1**
 - **X2**
 - **X3**
- ▶ Select **Linear** to configure LEC for the input
- ▶ Press the **enter** key to confirm the selection
- ▶ Press the **Auto Calc** soft key to begin teaching the LEC factor
- ▶ Touch one edge of the standard with the tool
- ▶ Press the **Teach Edge 1** soft key
- ▶ Touch the opposite edge of the standard with the tool
- ▶ Press the **Teach Edge 2** soft key
- ▶ Enter the length of the standard in the **Actual** field
- ▶ Press the **enter** key to confirm the entered value
- ▶ Repeat these steps for each axis you want to configure with linear error compensation
- ▶ Press the **enter** key to save the **Error Compensation** parameter changes and return to the **Installation Setup** menu
- or
- ▶ Press the **C** key to cancel

Configuring Segmented LEC

Segmented LEC should be applied if the results of the comparison with a reference standard show an alternating, or oscillating deviation. The required correction values are calculated, and entered in a table. The product supports up to 200 points per axis. The error value between two entered adjacent correction points is calculated with linear interpolation.



Segmented LEC is only available on scales with reference marks. If Segmented LEC has been defined, no error compensation will be applied until the reference marks have been crossed.

Segmented LEC setup

The encoder has an inherent count direction. This may not reflect the user defined count direction and is only required for determining Segmented LEC.



Single reference mark encoders must cross the same reference mark each time the product is powered on.

To establish the inherent count direction for any installed encoder on a given axis, complete the following:

- ▶ Press the **Setup** soft key
- ▶ Open in the sequence
 - **Installation Setup**
 - **Encoder Setup**
- ▶ Select the input to configure:
 - **X1**
 - **X2**
 - **X3**
- ▶ Select **Count Direction**
- ▶ Press the **Positive/Negative** soft key and select **Positive**
- ▶ Press the **enter** key to confirm the entered value
- ▶ Press the **enter** key to save the parameter changes
- ▶ Press the **C** key three times to return to the main display
- ▶ Move the axis that the encoder is mounted on and note the direction of movement required for the positive direction
- > The encoder's inherent count direction is now established.

Starting a Segmented LEC table

To start a Segmented LEC table:

- ▶ Press the **Setup** soft key
- ▶ Open in the sequence
 - **Installation Setup**
 - **Error Compensation**
- ▶ Select the input to configure:
 - **X1**
 - **X2**
 - **X3**
- ▶ Select **Segmented** to configure Segmented LEC for the input
- ▶ Press the **enter** key to confirm the selection
- ▶ Press the **Create Table** soft key to begin creating the table

All correction points (up to 200) are equally spaced from the start point.
- ▶ Enter the **Number of points**
- ▶ Press the **down arrow** key
- ▶ Enter the **Spacing of Points**
- ▶ Press the **down arrow** key

The start point is measured from the encoder's reference point.
If this distance is known:
- ▶ Enter the **Start Point** distance

or

If this distance is not known:
- ▶ Move to the location of the start point
- ▶ Press the **Teach** soft key
- ▶ Press the **enter** key to confirm the entered values
- ▶ A pop-up warning informs you that creating a new table will clear any existing error points
- ▶ Press the **enter** key to save the table and return to the **Error Compensation** menu
- ▶ Repeat these steps for each axis you want to create a Segmented LEC table

Configuring a Segmented LEC table

- ▶ Press the **Edit Table** soft key to view the table entries
- ▶ Press the **up** or **down arrow** keys or the **numeric** keys to move to the correction point to be added or changed
- ▶ Press the **right arrow** key
- ▶ Enter the known deviation which exists at this point
- ▶ Press the **enter** key
- ▶ Repeat these steps for each point that requires a correction point
- ▶ Press the **enter** key to exit the table and return to the **Error Compensation** menu

8.3.9 Backlash compensation

When using a rotary encoder with a lead screw, a change in direction of the table might cause an error in the displayed position due to clearances within the lead screw assembly. This clearance is referred to as backlash. This error can be compensated for by inputting the amount of backlash within the lead screw into the Backlash Compensation feature.

If the rotary encoder is ahead of the table (displayed value is greater than the table's true position), this is called positive backlash, and the value entered should be the positive value of the amount of error.

No Backlash Compensation is 0.000.

To specify backlash compensation:

- ▶ Press the **Setup** soft key
 - ▶ Open in the sequence
 - **Installation Setup**
 - **Backlash Comp.**
 - ▶ Select the input to configure:
 - **X1**
 - **X2**
 - **X3**
 - ▶ Press the **On/Off** soft key and select **On**
 - ▶ Enter the backlash compensation value
 - ▶ Repeat these steps for all axes that require backlash compensation
 - ▶ Press the **enter** key to save the backlash compensation values and return to the **Installation Setup** menu
- or
- ▶ Press the **C** key to cancel

8.4 Job Setup

The **Job Setup** menu is used to establish specific machining requirements for each job.

8.4.1 Units

Units parameters are used to specify the preferred display units and format. You can also select the unit of measure by pressing the **inch/mm** key in either operating mode.

To set the unit of measure:

- ▶ Press the **Setup** soft key
- ▶ Open in the sequence
 - **Job Setup**
 - **Units**
- ▶ Select the **Linear** units of measure:
 - **inch**
 - **mm**
- ▶ Press the **enter** key to confirm the selection
- ▶ Select the **Angular** units of measure:
 - **Decimal Degrees**
 - **Radians**
 - **DMS**: Degrees, Minutes, Seconds
- ▶ Press the **enter** key to confirm the selection
- ▶ Press the **enter** key to save the **Units** parameter changes and return to the **Job Setup** menu
- or
- ▶ Press the **C** key to cancel

8.4.2 Scale Factor

Scale Factor is used to scale a part up or down. A scale factor of 1.0 creates a part with the exact size as dimensioned on a print. A scale factor >1 "grows" the part, and <1 "shrinks" the part.

 The **Scale Factor** setting range is ± 0.100 to 100.000

Settings are retained on a power cycle.

When the **Scale Factor** is a value other than 1, the scaling symbol  is shown on the axis display.

To set a **Scale Factor**:

- ▶ Press the **Setup** soft key
- ▶ Open in the sequence
 - **Job Setup**
 - **Scale Factor**
- ▶ Select the axis to configure
- ▶ Press the **On/Off** soft key and select **On**
- ▶ Enter the **Scale Factor** value
- ▶ Repeat these steps for all axes that require a **Scale Factor**
- ▶ Press the **enter** key to save the values and return to the **Job Setup** menu
or
- ▶ Press the **C** key to cancel

Mirroring a part

A **Scale Factor** of -1.00 will produce a mirror image of the part. You can both mirror and scale a part at the same time.

8.4.3 Diameter Axes

Diameter Axes parameters are used to set which axes can display radius or diameter values.

To setup the display of radius or diameter values:

- ▶ Press the **Setup** soft key
- ▶ Open in the sequence
 - **Job Setup**
 - **Diameter Axes**
- ▶ Select the desired axis to setup
- ▶ Press the **On/Off** soft key and select **On** to enable the display of radius or diameter values for the selected axis
- ▶ Repeat these steps for each axis to enable
- ▶ Press the **enter** key to save the **Diameter Axes** parameter changes and return to the **Job Setup** menu
or
- ▶ Press the **C** key to cancel

8.4.4 Graphic positioning aid

Graphic positioning aids are displayed below each axis in Distance-To-Go (Inc) mode. Each axis has its own range that can be set.

Further information: "Graphic positioning aid", Page 54

To configure graphic positioning aid settings:

- ▶ Press the **Setup** soft key
- ▶ Open in the sequence
 - **Job Setup**
 - **Graphic Pos Aid**
- ▶ Select the desired axis to setup
The default range setting is 5.000 mm.
- ▶ Press the **On/Off** soft key to select **On** and use the default range setting
or
- ▶ Enter a range setting using the numeric keypad
- ▶ Repeat the process for each axis you would like to set
- ▶ Press the **enter** key to save the **Graphic Pos Aid** parameter changes and return to the **Job Setup** menu
or
- ▶ Press the **C** key to cancel

8.4.5 Status Bar Settings

The Status Bar is the segmented bar at the side of the display that shows the current **Datum, Tool, Feed Rate, Stopwatch** time, **Units**, operating mode status, **Set/Zero** setting, and the **Current User**.

To configure the status bar settings:

- ▶ Press the **Setup** soft key
- ▶ Open in the sequence
 - **Job Setup**
 - **Status Bar Settings**
- ▶ Select a parameter
- ▶ Press the **On/Off** soft key to enable or disable the selected option from being displayed in the status bar
- ▶ Repeat for each option you would like to enable or disable
- ▶ Press the **enter** key to save the **Status Bar Settings** parameter changes and return to the **Job Setup** menu
or
- ▶ Press the **C** key to cancel

8.4.6 Stopwatch

The **Stopwatch** shows the hours, minutes, and seconds elapsed time. The clock starts timing from 00:00:00.

The **Stopwatch** can also be operated in the DRO screen using the numeric keypad.

Further information: "Stopwatch", Page 55

Accessing the Stopwatch controls

To access the controls:

- ▶ Press the **Setup** soft key
- ▶ Open in the sequence
 - **Job Setup**
 - **Stopwatch**

Starting and stopping the Stopwatch

To start or stop the **Stopwatch**:

- ▶ Press the **Start/Stop** soft key to start or stop the **Stopwatch**
- > The **Elapsed Time** field shows the total accumulated time

Resetting the stopwatch

To reset the **Stopwatch**:

- ▶ Press the **Reset** soft key to reset the stopwatch time

8.4.7 Display Settings

Display Settings parameters are used to adjust the appearance of the display.

To configure **Display Settings**:

- ▶ Press the **Setup** soft key
 - ▶ Open in the sequence
 - **Job Setup**
 - **Display Settings**
 - ▶ Use the **left** or **right arrow** key to adjust the **Brightness** level of the display
The display brightness can also be adjusted using the **up** and **down arrow** keys when the product is in either operating mode.
 - ▶ Select the time in minutes that the display is idle before the **Display Saver (min)** is activated and the display is switched off:
 - **Off**
 - **10**
 - **30**
 - ▶ Press the **enter** key to confirm the selection
 - ▶ Press the **Day/Night** soft key to select the desired **Color Mode**:
 - **Night**
 - **Day**
 - ▶ Select how the axis that is in motion is displayed:
 - **Normal**: All axes are displayed normal
 - **Dynamic Zoom**: The axis in motion is displayed larger than axes not in motion
 - **Highlight**: In **Day** mode axes in motion are displayed in black, axes not in motion are displayed in gray. In **Night** mode axes in motion are displayed in white, axes not in motion are displayed in gray.
-  If **Dynamic Zoom** or **Highlight** is selected, the feature can be toggled on and off from the DRO screen.
To toggle the feature:

 - ▶ Press the **+/-** key
- ▶ Press the **enter** key to confirm the selection
 - ▶ Enter the number of seconds, in the **Zoom Timeout (sec)** field, that **Dynamic Zoom** or **Highlight** stays active after axis movement has stopped
Axes labels can be positioned on the left or the right. When the labels are positioned on the left, the left axes keys are used for operation. When the labels are positioned on the right, the right axes keys are used for operation.
 - ▶ Press the **Left/Right** soft key to select the **Axes Label Position**
 - ▶ Press the **enter** key to save the **Display Settings** parameter changes and return to the **Job Setup** menu
 - or
 - ▶ Press the **C** key to cancel

8.4.8 System Information

The **System Information** screen provides product and software information.

Available information:

- **Product Name**
- **Product ID**
- **Serial Number**
- **Software Version**
- **Bootloader Version**
- **FPGA Version**
- **Board ID**

To access **System Information**:

- ▶ Press the **Setup** soft key
- ▶ Open in the sequence
 - **Job Setup**
 - **System Information**
- ▶ Press the **enter** key
- > The **System Information** screen is displayed
- ▶ Press the **C** key to exit **System Information**

8.4.9 Language

The **Language** parameter is used to select the language for the user interface. The default language is English.

To change the Language:

- ▶ Press the **Setup** soft key
- ▶ Open in the sequence
 - **Job Setup**
 - **Language**
- ▶ Select the desired language
- ▶ Press the **enter** key to confirm the selection
- ▶ Press the **enter** key to save the **Language** parameter change and return to the **Job Setup** menu
- or
- ▶ Press the **C** key to cancel

9

**Milling specific
operations**

9.1 Overview

This chapter describes operations and soft key functions specific to milling applications.

i Make sure that you have read and understood the "Basic Operation" chapter before performing the activities described in this section.

Further information: "Basic operation", Page 49

9.2 1/2 soft key

The **1/2** soft key is available when the product is setup for milling applications and is used to find the centerline (or midpoint) between two locations along a selected axis of a workpiece. This can be performed in either Actual Value or Distance-To-Go mode.

i This feature will change datum locations when in Actual Value mode.

Example: Finding the midpoint along a selected axis

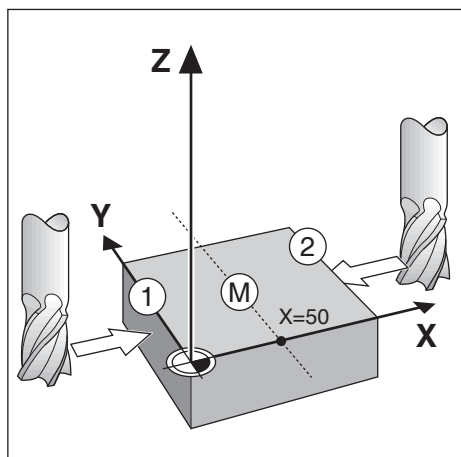

X dimension: X = 100 mm

Midpoint: 50 mm

To find the midpoint:

- ▶ Move the tool to the first point
The **Set/Zero** soft key must be set to **Zero**.
- ▶ Press the **X axis** key
- ▶ Move to the second point
- ▶ Press the **1/2** soft key
- ▶ Press the **X axis** key
- ▶ Move the tool until zero is reached
- > This is the midpoint location

9.3 Tool Table

The **Tool Table** is used to store diameter and length offset information for tools. The **Tool Table** can store information for up to 16 tools.

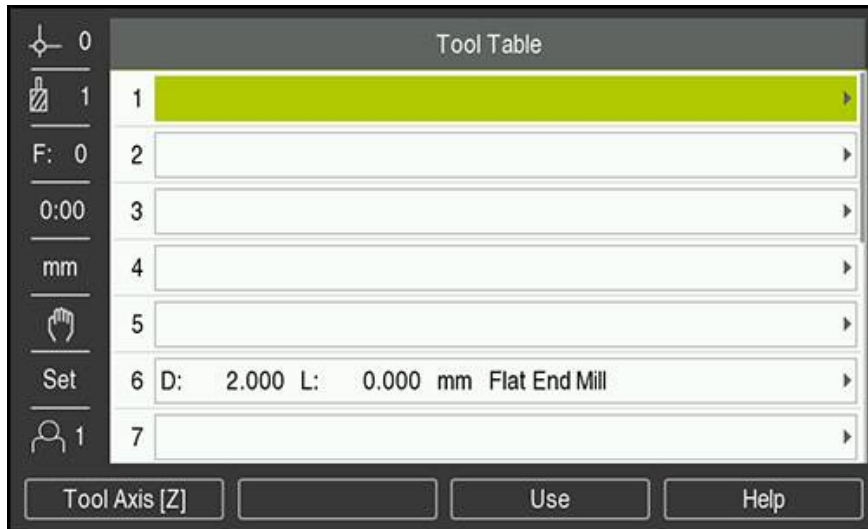

Opening the Tool Table

To open the **Tool Table**:

- ▶ Press the **Tool** soft key

Selecting a Tool

To select a **Tool**:

- ▶ Use the **up** or **down arrow** key to highlight a tool or
- ▶ Enter the tool number using the numeric key pad
- ▶ Press the **right arrow** key or
- ▶ Press the **enter** key
- > The tool form for the selected tool is displayed

9.3.1 Soft keys

The following soft keys are available in the **Tool Table** form or in the individual tool data form:

Soft key	Function
Tool Axis	Press the Tool Axis soft key to toggle and select which axis the tool length offsets will affect. The tool's diameter values will subsequently be used to offset the remaining two axes.
Teach	Press the Teach soft key to automatically enter the tool offset length. This key is only available in the Length field.
Clear	Press the Clear soft key to remove a tool from the table
Use	Press the Use soft key to select the highlighted tool from the table
Help	Press the Help soft key to access Tool Table specific help

9.3.2 Importing and exporting

A **Tool Table** can be imported from an existing file or exported for backup and future use.

Further information: "Tool Table", Page 70

9.3.3 Tool compensation

Tool compensation allows you to enter workpiece dimensions directly from the drawing.

Radius compensation

Tool radius compensation is calculated based on the value entered in the **Diameter** field in the **Tool** form.

R represents the tool radius. The displayed distance-to-go is automatically lengthened **R+**, or shortened **R-** by the value of the tool radius.

Further information: "Presetting a target position", Page 103

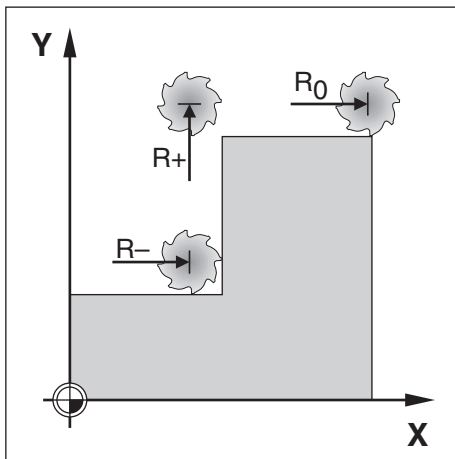

Length offset

Tool length offset is calculated based on the value entered into the **Length** field in the **Tool** form. The length offset can be entered as a known value or the product can teach the offset.

Further information: "Entering tool data", Page 96

The tool length is the difference in length ΔL between the tool and the reference tool. The length difference is indicated with the " Δ " symbol. The reference tool is indicated by T1.

- If the tool is **longer** than the reference tool: $\Delta L > 0 (+)$
- If the tool is **shorter** than the reference tool: $\Delta L < 0 (-)$

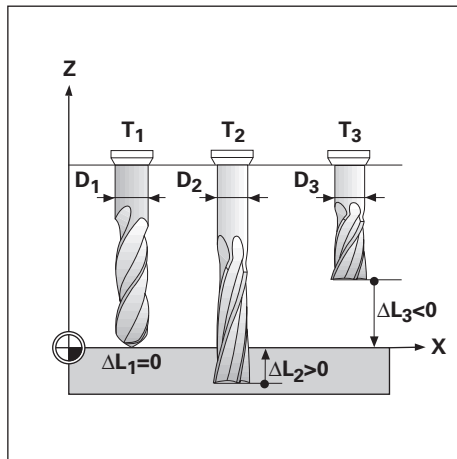

9.3.4 Entering tool data

		Tool (1)		Position	
0					
1	Diameter	4.500	X	0.000	
F: 0	Length	0.000	Y	0.000	
0:00	Units	mm	Z	0.000	
mm	Type	Flat End Mill			
Set					
1					

Help

To enter data into a **Tool** form:

- ▶ Press the **Tool** soft key
- ▶ Use the **up** or **down arrow** key to highlight the desired tool
or
- ▶ Enter the tool number using the numeric keypad
- ▶ Press the **Enter** key
- ▶ The **Tool** form for the selected tool is displayed
- ▶ Enter the tool **Diameter**
- ▶ Enter the tool **Length**
or
- ▶ Press the **Teach** soft key and follow the procedure for **Teaching length offset** described in this section.
- ▶ Select the tool **Units**
 - inch
 - mm
- ▶ Select the tool **Type**
 - Not Defined
 - Ball End Mill
 - Boring Head
 - Broach
 - Carbide Mill
 - Counter Bore
 - Counter Sink
 - Drill
 - Engraving Tip
 - Flat End Mill
 - Fly Cutter
 - Pilot Drill
 - Reamer
 - Roughing Mill
 - Shell End Mill
 - Special Mill
 - Tap
- ▶ Press the **enter** key to save the tool changes and return to the **Tool Table**

Teaching length offset

It is also possible to have the product determine an offset. This method involves touching the tip of each tool to a common reference surface. This allows the product to determine the difference between the length of each tool.

i Only the tools set using the same reference surface may be changed without having to reset the datum.

i If the tool table already contains tools in which the length has been set, the reference surface should first be established using one of them. If not, you will not be able to switch between the new tools and the existing tools without having to re-establish the datum. Before adding the new tools, select one of the tools from the tool table. Touch the tool to a reference surface and set the datum to 0

To teach **Length Offset**:

- ▶ Move the tool until its tip is touching the reference surface
- ▶ Press the **Teach** soft key
- ▶ The product will calculate an offset relative to the reference surface
- ▶ Repeat the procedure for each additional tool using the same reference surface

9.3.5 Selecting a tool

Before you start machining, select the tool you are using from the **Tool Table**. The product then takes into account the stored tool data when working with tool compensation.

To select a tool:

- ▶ Press the **Tool** soft key
- ▶ Use the **up** or **down arrow** keys to highlight the tool you want to select
- ▶ Press the **Use** soft key
- ▶ Verify in the status bar that the correct tool was selected

9.4 Setting a datum

Datum settings define the relationships between the axis positions and the display values.

The easiest way to set datum points is to use the probing function when probing the workpiece with the edge of a tool.

Datum points can also be set by touching the edges of the workpiece, one after the other with a tool, and manually entering the tool positions as datum points.

The datum table can hold up to 10 datum points. In most cases this will eliminate from having to calculate the axis travel when working with complicated workpiece drawings containing several datums.

9.4.1 Setting a workpiece datum without using the probing function

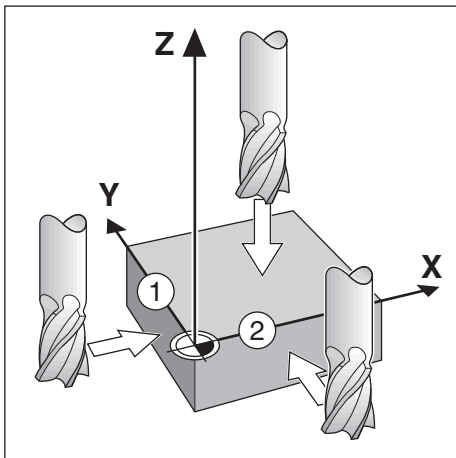

Datum		Position		
0	Datum Number	0	X	0.000
1	X	-1.500	Y	0.000
F: 0	Y	-1.500	Z	0.000
0:00	Z	0.000		
mm	Enter new actual position of tool or press Probe.			
Set				
1				

Probe Calc Help

- Axis sequence in this example: X - Y - Z
To set a datum without the probing function:
 - ▶ Press the **Datum** soft key
 - ▶ Enter the **Datum Number**
 - ▶ Highlight the X axis field
 - ▶ Touch the workpiece at edge **1**
 - ▶ Enter the position of the tool center (X = 1.5 mm)
 - ▶ Highlight the Y axis field
 - ▶ Touch the workpiece at edge **2**
 - ▶ Enter the position of the tool center (Y = 1.5 mm)
 - ▶ Highlight the Z axis field
 - ▶ Touch the workpiece surface
 - ▶ Enter the position of the tool tip (Z = 0 mm) for the Z coordinate of the datum
 - ▶ Press the **enter** key

9.4.2 Probing with a tool

A tool or non-electrical edge finder can be used to set datum points.

The following probing functions are available:

- Workpiece edge as datum: **Edge** soft key
- Centerline between two workpiece edges: **Center Line** soft key
- Center of a hole or cylinder: **Circle Center** soft key

In all probing functions the product takes into account the current tool's tip diameter.

Canceling a probing function

To cancel a probing function while it is active:

- ▶ Press the **C** key

Probing an Edge with a tool

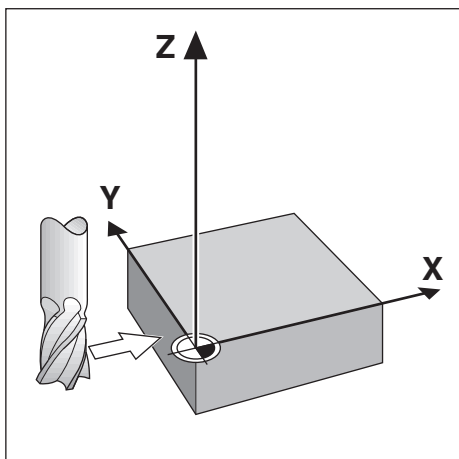

Datum		Position	
Datum Number	<input type="text" value="0"/>	X	<input type="text" value="0.000"/>
X	<input type="text"/>	Y	<input type="text" value="0.000"/>
Y	<input type="text"/>	Z	<input type="text" value="0.000"/>
Z	<input type="text"/>		
Select the probe function.			
Edge		Center Line	
Circle Center		Help	

To probe an edge with a tool:

- ▶ Set the active tool to the tool that will be used to set the datum
- ▶ Press the **Datum** soft key
- ▶ Enter the **Datum Number**
- ▶ Highlight the **X** axis field
- ▶ Press the **Probe** soft key
- ▶ Press the **Edge** soft key
- ▶ Touch the workpiece edge
- ▶ Press the **Teach** soft key

The **Teach** soft key is useful when determining tool data by touching the workpiece in the absence of an edge finder with feedback. To avoid losing the position value when the tool is retracted, press the **Teach** soft key to store the value while it is in contact with the workpiece edge. The location for the touched edge will take into account the diameter of the tool in use (T:1, 2...), and the last direction the tool was moved prior to pressing the **Teach** soft key.

- ▶ Retract the tool from the workpiece
- ▶ Enter the position of the workpiece edge
- ▶ Press the **enter** key

Probing a Center Line with a tool

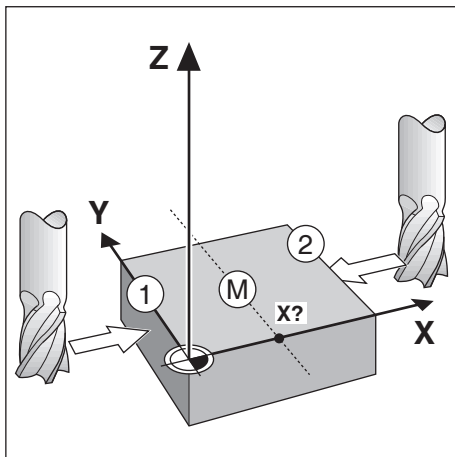

Datum		Position	
Datum Number	<input type="text" value="0"/>	X	<input type="text" value="0.000"/>
X	<input style="background-color: yellow;" type="text"/>	Y	<input type="text" value="0.000"/>
Y	<input type="text"/>	Z	<input type="text" value="0.000"/>
Z	<input type="text"/>		
Move to the first edge and press Teach.			
		<input type="button" value="Teach"/>	<input type="button" value="Help"/>

To probe a centerline with a tool:

- ▶ Set the active tool to the tool that will be used to set the datum
- ▶ Press the **Datum** soft key
- ▶ Enter the **Datum Number**
- ▶ Highlight the **X** axis field
- ▶ Press the **Probe** soft key
- ▶ Press the **Center Line** soft key
- ▶ Touch the first workpiece edge **1**
- ▶ Press the **Teach** soft key
- ▶ Touch the second workpiece edge **2**
- ▶ Press the **Teach** soft key
- > The datum is set to 0.000 and the distance between the edges is displayed
- ▶ Retract the tool from the workpiece
- ▶ Enter the position of the workpiece centerline
- ▶ Press the **enter** key

Probing a Circle Center with a tool

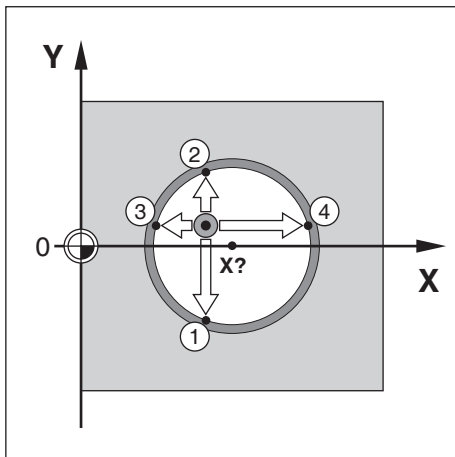

Datum		Position	
Datum Number	<input type="text" value="0"/>	X	<input type="text" value="0.000"/>
X	<input style="background-color: yellow;" type="text"/>	Y	<input type="text" value="0.000"/>
Y	<input type="text"/>	Z	<input type="text" value="0.000"/>
Z	<input type="text"/>		
Move to the first edge and press Teach.			
<input type="button" value="Teach"/> <input type="button" value="Help"/>			

To probe a **Circle Center** with a tool:

- ▶ Set the active tool to the tool that will be used to set the datum
- ▶ Press the **Datum** soft key
- ▶ Enter the **Datum Number**
- ▶ Highlight the **X** axis field
- ▶ Press the **Probe** soft key
- ▶ Press the **Circle Center** soft key
- ▶ Touch the first workpiece edge **1**
- ▶ Press the **Teach** soft key
- ▶ Touch the second workpiece edge **2**
- ▶ Press the **Teach** soft key
- ▶ Touch the third workpiece edge **3**
- ▶ Press the **Teach** soft key
- ▶ Touch the fourth workpiece edge **4**
- ▶ Press the **Teach** soft key
- > The **X** and **Y** datums are set to 0.000 and the diameter of the circle is displayed.
- ▶ Retract the tool from the workpiece
- ▶ Enter the **X** and **Y** axis position of the circle center
- ▶ Press the **enter** key

9.5 Presetting a target position

The **Preset** function allows you to indicate the nominal (target) position for the next move. Once the new nominal position information is entered the display will switch to Distance-To-Go mode and show the distance between the current position and the nominal position. You now only need to move the table until the display is zero and you will be at the required nominal position. The information for the location of the nominal position can be entered as an absolute move from the current datum zero or as an incremental move from the current nominal position.

Presetting also allows you to indicate which side of the tool will be doing the machining at the nominal position. The **R +/-** soft key in the **Preset** form defines the offset that will be in effect during the move. **R+** indicates that the center line of the current tool is in a more positive direction than the edge of the tool. **R-** indicates that the center line is in a more negative direction than the edge of the current tool. Using **R +/-** offsets automatically adjusts the distance-to-go value to account for the diameter of the tool.

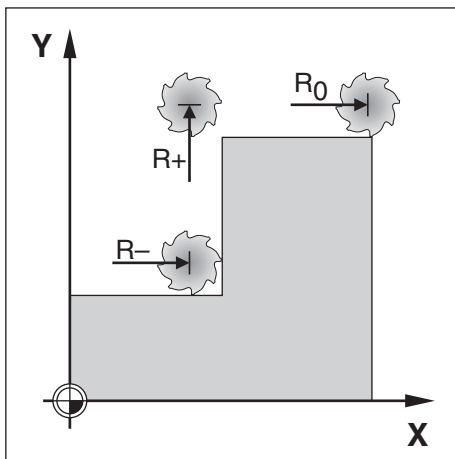

9.5.1 Absolute distance preset

Example

Milling a shoulder by traversing to display value zero using absolute position.

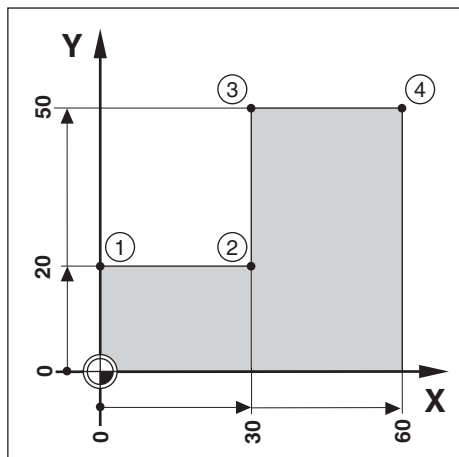

The coordinates are entered as absolute dimensions; the datum is the workpiece zero. Using this figure example:

- Corner 1: X = 0 / Y = 20
- Corner 2: X = 30 / Y = 20
- Corner 3: X = 30 / Y = 50
- Corner 4: X = 60 / Y = 50



Press the **Preset** soft key, then an axis key to recall the last entered preset value for that axis.

Preparation

- ▶ Select the tool with the appropriate tool data
- ▶ Pre-position the tool to an appropriate location (such as X = Y = -10)
- ▶ Move the tool to milling depth
- ▶ Press the **Preset** soft key
- ▶ Press the **Y axis** key

Alternative method one

- ▶ Press the **Set/Zero** soft key so that you are in **Set** mode
- ▶ Press the **Y axis** key
- ▶ Enter the nominal position value for corner point **1**: Y = 20
- ▶ Select **R +** with the **R +/-** soft key
- ▶ Press the **enter** key
- ▶ Traverse the **Y** axis until the display value is zero
- > The square in the graphical positioning aid is now centered between the two center marks.
- ▶ Press the **Preset** soft key
- ▶ Press the **X axis** key

Alternative method two

- ▶ Press the **Set/Zero** soft key so that you are in **Set** mode
 - ▶ Press the **X axis** key
 - ▶ Enter nominal position value for corner point **2**: X = 30
 - ▶ Select **R -** with the **R +/-** soft key
 - ▶ Press the **enter** key
 - ▶ Traverse the **X** axis until the display value is zero
 - > The square in the near zero warning is now centered between the two center marks
- Presets can be entered in the same manner for corners **3** and **4**.

9.5.2 Incremental distance preset

Example

Drilling by traversing to display value zero with incremental positioning.

i Enter the coordinates in incremental dimensions. These are indicated in the following (and on the screen) with a preceding I (Incremental). The datum is the workpiece zero.

- Hole 1 at: $X = 20 / Y = 20$
- Distance from hole 1 to hole 2: $XI = 30 / YI = 30$
- Hole depth: $Z = -20$
- Operating mode: Distance-To-Go (Inc)

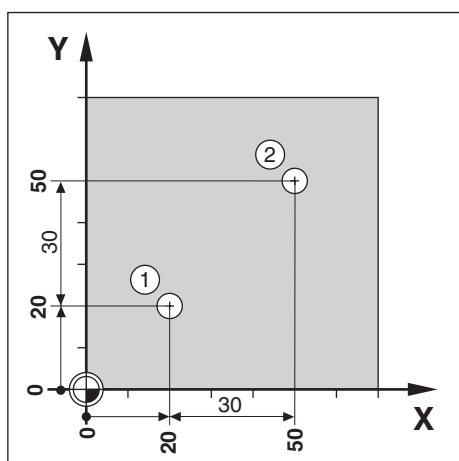

To preset the location for hole 1:

- ▶ Press the **Preset** soft key
- ▶ Press the **X axis** key
- ▶ Enter the nominal position value for hole 1: $X = 20$ and ensure no tool radius is active

Note that these presets are Absolute Presets.

- ▶ Press the **down arrow** key
- ▶ Enter the nominal position value for hole 1: $Y = 20$
- ▶ Ensure no tool radius compensation is showing
- ▶ Press the **down arrow** key
- ▶ Enter the nominal position value for the hole depth: $Z = -20$
- ▶ Press the **enter** key
- ▶ Drill hole 1: Traverse the **X**, **Y**, and **Z** axis until the display value is zero
- ▶ The square in the graphical positioning aid is now centered between the two center marks
- ▶ Retract the drill

To preset the location for hole 2:

- ▶ Press the **Preset** soft key
- ▶ Press the **X axis** key
- ▶ Enter the nominal position value for hole 2: $X = 30$
- ▶ Press the **I** soft key to mark your input as an incremental dimension
- ▶ Press the **Y axis** key
- ▶ Enter the nominal position value for hole 2: $Y = 30$

- ▶ Press the **I** soft key to mark your input as an incremental dimension
- ▶ Press the **enter** key
- ▶ Traverse the **X** and **Y** axes until the display value is zero
- ▶ The square in the graphical positioning aid is now centered between the two center marks
To preset the **Z** axis:
 - ▶ Press the **Preset** soft key
 - ▶ Press the **Z axis** key
 - ▶ Press the **enter** key to use the last entered preset
 - ▶ Drill hole **2**: Traverse the Z axis until the display value is zero
- ▶ The square in the near zero warning is now centered between the two center marks
- ▶ Retract the drill

9.6 Features

Pressing the **Features** soft key provides access to the **Circle Pattern**, **Linear Pattern**, **Incline Mill**, and **Arc Mill** milling features.

The **Circle Pattern** and **Linear Pattern** features provide ways to calculate and machine various hole patterns. The **Incline Mill** and **Arc Mill** features provide ways to machine a flat diagonal surface (**Incline Mill**), or a rounded surface (**Arc Mill**) using a manual machine.



Defined patterns are remembered when power is cycled.

The following milling **Features** soft keys are available:

Soft key	Function
Circle Pattern	Press the Circle Pattern soft key to access the Circle Pattern table
Linear Pattern	Press the Linear Pattern soft key to access the Linear Pattern table
Incline Mill	Press the Incline Mill soft key to access the Incline Mill form
Arc Mill	Press the Arc Mill soft key to access the Arc Mill form

9.6.1 Circle and linear patterns

This section describes the circle and linear pattern tables and capabilities. The product provides storage of ten user definable patterns each for circle and linear. Once patterns are defined, they are remembered when power is cycled. They can be recalled and executed from the DRO.

To access the **Circle Pattern** table or **Linear Pattern** table:





- ▶ Press the **Features** soft key
- > The **Circle Pattern** and **Linear Pattern** soft keys are shown
- ▶ Press the **Circle Pattern** soft key to access the **Circle Pattern** table
or
- ▶ Press the **Linear Pattern** soft key to access the **Linear Pattern** table
- > The corresponding hole pattern table will open

The following soft keys are available while in the **Circle Pattern** and **Linear Pattern** tables.

Function	Soft key
New	Press the New soft key to create a new circle or linear pattern
Edit	Press the Edit soft key to edit an existing pattern
Clear	Press the Clear soft key to delete an existing pattern
Run	Press the Run soft key to execute a pattern
Help	Press the Help soft key for additional information about the pattern

Circle and linear hole patterns

Required Circle Pattern information

		Circle Pattern (1)	Position	
	0			
	1	Type Full	X	0.000
F:	0	Holes	Y	0.000
0:00		X Center	Z	0.000
mm		Y Center		
		Radius		
Set		Start Angle		
	1	Step Angle		

- **Type:** type of pattern, **Full** or **Segment**
- **Holes:** number of holes in the pattern
- **X Center:** X axis location of the center of the hole pattern
- **Y Center:** Y axis location of the center of the hole pattern
- **Radius:** radius of the pattern
- **Start Angle:** angle between X axis and the first hole
- **Step Angle:** angle between each hole
- **Z Depth:** the target depth for drilling in the tool axis

Required Linear Pattern information

		Linear Pattern (1)	Position		
0		Type	Array	X	0.000
1		X First Hole	0.000	Y	0.000
F: 0		Y First Hole	0.000	Z	0.000
0:00		Holes Per Row	1		
mm		Hole Spacing	0.000		
		Angle	0.0000°		
Set		Z Depth			
1					

Buttons: [] [] [] [Help]

- **Type:** type of pattern, **Array** or **Frame**
- **X First Hole:** X axis location of the first hole of the pattern
- **Y First Hole:** Y axis location of the first hole of the pattern
- **Holes Per Row:** number of holes in each row of a pattern
- **Hole Spacing:** the spacing between each hole in a row
- **Angle:** the angle or rotation of the pattern
- **Z Depth:** the target depth for drilling in the tool axis
- **Number of Rows:** the number of rows in the pattern
- **Row Spacing:** the spacing between each row of the pattern

The **Circle Pattern** or **Linear Pattern** table is used to define up to ten different circle hole patterns (Full or Segment) and ten different linear hole patterns (Array or Frame).

Creating and editing a pattern

To create or edit a pattern in the table:

- ▶ Press the **Features** soft key
- ▶ Press the **Circle Pattern** or **Linear Pattern** soft key
- > The pattern table will show any patterns that have been previously defined
- ▶ Press the **up** or **down arrow** keys to highlight a table entry
- ▶ Press the **New** soft key to create a new entry or press the **Edit** soft key to edit an existing entry
- or
- ▶ Press the **enter** key
- > The pattern form is opened
- ▶ Enter the information to define the pattern
- ▶ Press the **enter** key
- > The pattern will be entered into the appropriate table. It can now be modified or executed.

Deleting a pattern

To delete a pattern from the table:

- ▶ Press the **Features** soft key
- ▶ Press the **Circle Pattern** or **Linear Pattern** soft key
- ▶ Press the **up** or **down arrow** keys to highlight the pattern you would like to delete
- ▶ Press the **Clear** soft key
- ▶ Press the **enter** key to confirm deleting the pattern from the table

Running a pattern

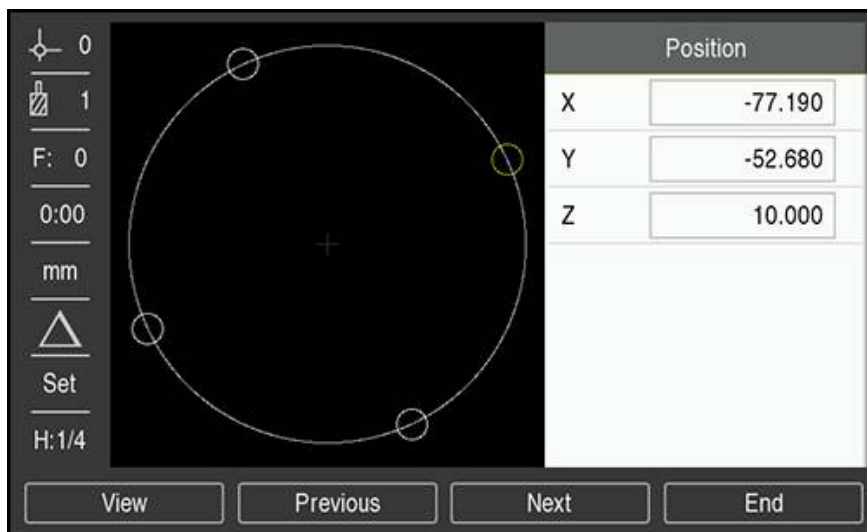

To run a pattern:

- ▶ Press the **Features** soft key
- ▶ Press the **Circle Pattern** or **Linear Pattern** soft key
- ▶ Press the **up** or **down arrow** keys to highlight the pattern you would like to run
- ▶ Press the **Run** soft key
- ▶ The product calculates the positions of the holes and can also provide a graphical view of the hole pattern

The following soft keys are available while running a pattern:

Soft key	Function
View	Press the View soft key to select the graphic view of the pattern.
Previous	Press the Previous soft key to select the previous hole in the pattern
Next	Press the Next soft key to select the next hole in the pattern
End	Press the End soft key to end execution of the pattern

i Press the **View** soft key to toggle the views between Distance-to-Go (Inc) positions, graphic view, and Actual Value (Abs) positions.

i The diameter of the active tool is displayed when in the graphic view.

Example: Entering data and running a circle pattern

0		Circle Pattern (1)		Position	
1	Type	Full		X	0.000
F: 0	Holes		4	Y	0.000
0:00	X Center		50.000	Z	0.000
mm	Y Center		40.000		
	Radius		30.000		
Set	Start Angle		25.0000°		
1	Step Angle		90.0000°		

Help

Entering the data:

- ▶ Press the **Features** soft key
- ▶ Press the **Circle Pattern** soft key
- ▶ Press the **up** or **down arrow** keys to select pattern **1**
- ▶ Press the **enter** key
- ▶ Select **Full** in the **Type** field
- ▶ Press the **down arrow** key to move to the next field
- ▶ Enter 4 for the number of **Holes**
- ▶ Enter 50 mm for the **X Center** location
- ▶ Enter 40 mm for the **Y Center** location
- ▶ Enter 125 mm for the **Radius** of the circle pattern
- ▶ Enter 25° for the **Start Angle**
- ▶ The **Step Angle** is 90° and cannot be changed because the **Type** is **Full**
- ▶ Enter a **Z Depth** of -10 mm
The depth of the hole is optional and may be left blank
- ▶ Press the **enter** key
- ▶ The **Circle Pattern Table** now shows the pattern that was just defined as pattern **1**

0	-77.190	X
1	-52.680	Y
F: 0	10.000	Z
0:00		
mm		
Set		
H:1/4		

View Previous Next End

Running the pattern:

- ▶ Press the **Run** soft key
- ▶ The Distance-To-Go view is displayed
- ▶ Move to the hole, move the **X** and **Y** axis until their display values show 0.0
- ▶ Drill (Z depth): If a depth was entered into the pattern, move **Z** until it's display value shows 0.0. otherwise, drill to the desired depth
- ▶ Press the **Next** soft key
- ▶ Continue to drill the remaining holes in the same manner
- ▶ When the pattern is complete, press the **End** soft key

9.6.2 Incline and arc milling

The incline and arc milling features provide ways to machine a flat diagonal surface (incline milling) or a rounded surface (arc milling) using a manual machine. The product provides storage of ten user definable Incline Mill features and ten Arc Mill features. Once the features are defined, they are remembered when power is cycled. They can be recalled and executed from the DRO.

To access the **Incline Mill** or **Arc Mill** table:

- ▶ Press the **Features** soft key
- > The **Incline Mill** and **Arc Mill** soft keys are shown
- ▶ Press the **Incline Mill** soft key to access the **Incline Mill** table
- or
- ▶ Press the **Arc Mill** soft key to access the **Arc Mill** table
- > The corresponding mill table will open

The following soft keys are available while in the **Incline Mill** and **Arc Mill** tables.

Function	Soft key
New	Press the New soft key to create a new Incline Mill or Arc Mill feature
Edit	Press the Edit soft key to edit an existing milling feature
Clear	Press the Clear soft key to delete an existing milling feature
Run	Press the Run soft key to execute a milling feature
Help	Press the Help soft key for additional information about the milling feature

Incline and arc milling features

Required Incline Mill information

		Incline Mill (1)	Position	
	0			
	1	Plane	XY	X
F:	0	X Start	0.000	Y
	0:00	Y Start	0.000	Z
	mm	X End	0.000	
		Y End	0.000	
Set		Step	0.000	
	1			

Buttons: [] [] [] [Help]

- **Plane:** the plane to be milled
- **X Start:** X axis start point
- **Y Start:** Y axis start point
- **X End:** X axis end point
- **Y End:** Y axis end point
- **Step:** The distance between each pass or each **Step** along the line



The **Step** size is optional. If the value is zero, the operator decides at run-time how far to move between each **Step**.

Required Arc Mill information

0		Arc Mill (1)		Position	
1	Plane	XY		X	0.000
F: 0	X Center		0.000	Y	0.000
0:00	Y Center		0.000	Z	0.000
mm	X Start		0.000		
	Y Start		0.000		
Set	X End		0.000		
1	Y End		0.000		

Help

- **Plane:** the plane to be milled
- **X Center:** X axis center point
- **Y Center:** Y axis center point
- **X Start:** X axis start point
- **Y Start:** Y axis start point
- **X End:** X axis end point
- **Y End:** Y axis end point
- **Step:** The distance along the circumference of the arc between each pass, or **Step** along the arc's contour



The **Step** size is optional. If the value is zero, the operator decides at run-time how far to move between each **Step**.

The **Incline Mill** or **Arc Mill** table is used to define up to ten different milling patterns.

Creating and editing a milling feature

To create or edit a feature in the table:

- ▶ Press the **Features** soft key
- ▶ Press the **Incline Mill** or **Arc Mill** soft key
- > The feature table will show any features that have been previously defined
- ▶ Press the **up** or **down arrow** key to highlight a table entry
- ▶ Press the **New** soft key to create a new entry or press the **Edit** soft key to edit an existing entry
- or
- ▶ Press the **enter** key
- > The feature form is opened
- ▶ Enter the information to define the feature
- ▶ Press the **enter** key
- > The feature will be entered into the appropriate table. It can now be modified or executed.

Deleting a feature

To delete a feature from the table:

- ▶ Press the **Features** soft key
- ▶ Press the **Incline Mill** or **Arc Mill** soft key
- ▶ Press the **up** or **down arrow** keys to highlight the feature you would like to delete
- ▶ Press the **Clear** soft key
- ▶ Press the **enter** key to confirm deleting the feature from the table

Running a feature

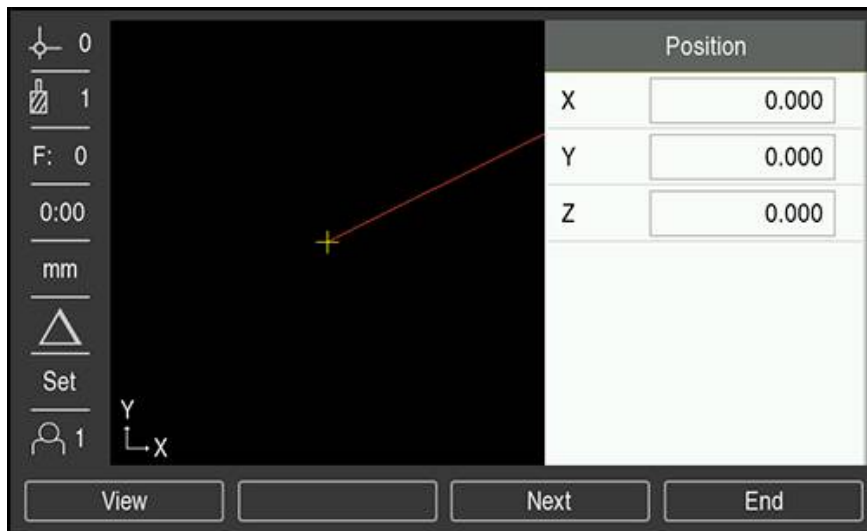

To run a feature:

- ▶ Press the **Features** soft key
- ▶ Press the **Incline Mill** or **Arc Mill** soft key
- ▶ Press the **up** or **down arrow** key to highlight the feature you would like to run
- ▶ Press the **Run** soft key
- ▶ The display switches to the incremental DRO view, showing the incremental distance from the start point

The following soft keys are available while running a pattern:

Soft key	Function
View	Press the View soft key to select the incremental DRO, contour view of feature, or absolute DRO
Previous	Press the Previous soft key to return to the previous pass
Next	Press the Next soft key to advance to the next pass
End	Press the End soft key to end execution of the milling operation

The tool radius compensation is applied based on the radius of the current tool. If the plane selection involves the tool axis, the tool tip is assumed to have a ball end.

- ▶ Move to the start point and make a plunge cut or the first pass across the surface
- ▶ Press the **Next** soft key to continue with the next step along the contour
- ▶ The incremental display shows the distance from the next pass along the line, or arc's contour
- ▶ To follow the contour, move the two axes in small steps, keeping the X, and Y positions as close to zero (0.0) as possible
- ▶ When no step size is specified, the incremental display always shows the distance from the closest point on the arc
- ▶ Press the **View** soft key to toggle through the three available views (incremental DRO, contour, and absolute DRO)

The contour view shows the position of the tool relative to the milling surface. When the cross hair representing the tool is on the line representing the surface, the tool is in position. The tool cross hair remains fixed in the center of the graph. As the table is moved, the surface line moves.

- ▶ Press the **End** soft key to exit the milling operation



The tool offset direction (**R+** or **R-**) is applied based on the tool position. The operator must approach the contour surface from the appropriate direction for tool compensation to be correct.

10

**Turning specific
operations**

10.1 Overview

This chapter describes operations and soft key functions specific to turning applications.



Make sure that you have read and understood the "Basic Operation" chapter before performing the activities described in this section.

Further information: "Basic operation", Page 49

10.2 Tool display icon

The \emptyset icon is used to indicate that the displayed value is a diameter value. No icon visible indicates that the display is a radius value.

10.3 Tool table

The product can store the dimensional offsets for up to 16 tools.

When you change a workpiece and establish a new datum, all tools are automatically referenced from the new datum.

10.3.1 Importing and exporting

A **Tool Table** can be imported from an existing file or exported for backup and future use.

Further information: "Tool Table", Page 70

10.3.2 Setting tool offsets

Before you can use a tool, you must enter its offset (the cutting edge position). Tool offsets can be set using the **Tool/Set** or **Note** feature.

Tool/Set

The **Tool/Set** feature can be used to set a tool's offset using a tool when the diameter of the workpiece is known.

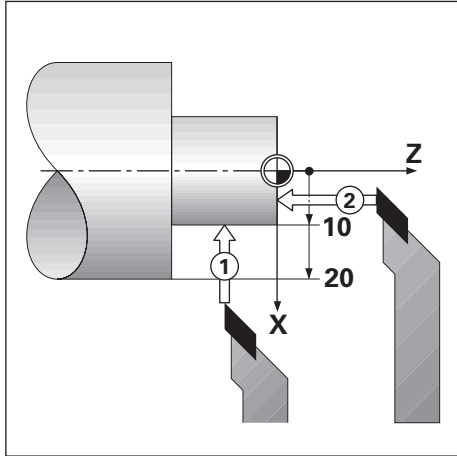

To set a tool offset using **Tool/Set**:

- ▶ Touch the known diameter in the X axis **1**
- ▶ Press the **Tool** soft key
- ▶ Highlight the desired tool
- ▶ Press the **enter** key
- ▶ Highlight the **X** axis field
- ▶ Enter the position of the tool tip, for example, X=10



Remember to ensure the product is in diameter display mode \emptyset if the input is a diameter value.

- ▶ Touch the workpiece face with the tool **2**
- ▶ Highlight the **Z** axis field
- ▶ Set the position display for the tool tip to zero, Z=0
- ▶ Press the **enter** key

Note

The **Note** feature can be used to set a tool's offset when a tool is under load and the diameter of the workpiece is not known.

The **Note** feature is useful when determining tool data by touching the workpiece. To avoid losing the position value when the tool is retracted to measure the workpiece, this value can be stored by pressing the **Note** soft key.

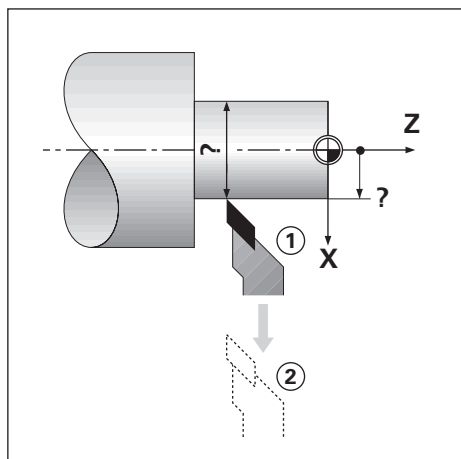

To set a tool offset using **Note**:

- ▶ Press the **Tool** soft key
- ▶ Highlight the desired tool
- ▶ Press the **enter** key
- ▶ Press the **X axis** key
- ▶ Turn a diameter in the X axis
- ▶ Press the **Note** soft key while the tool is still cutting
- ▶ Retract from the current position
- ▶ Turn the spindle off and measure the workpiece diameter
- ▶ Enter the measured diameter or radius

Remember to ensure the product is in diameter display mode \emptyset if you input a diameter value.

- ▶ Press the **enter** key

10.3.3 Selecting a tool

Before you start machining, select the tool you are using from the **Tool Table**.

The product then takes into account the stored tool data when working with tool compensation.

To select a tool:

- ▶ Press the **Tool** soft key
- ▶ Use the **up** or **down arrow** keys to highlight the tool you want to select
- ▶ Press the **Use** soft key
- ▶ Verify in the status bar that the correct tool was selected

10.4 Setting a datum

Datum settings define the relationships between the axis positions and the display values.

For most lathe operations there is only one X-axis datum, the center of the chuck, but it may be helpful to define additional datums for the Z-axis.

The datum table can hold up to 10 datum points.

The recommended way to set datum points is to touch a workpiece at a known diameter, or location, then enter that dimension as the value that the display should be showing.

10.4.1 Setting a datum manually

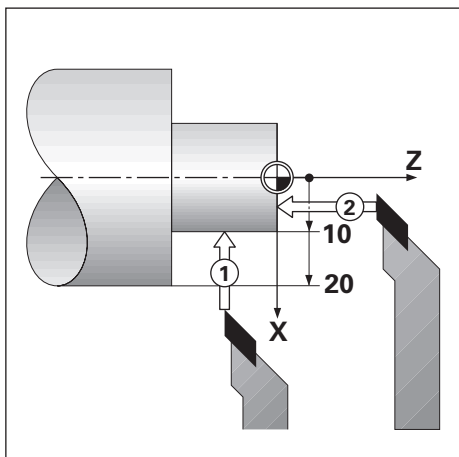

Datum		Position	
0	Datum Number	0	X 0.000 Ø
1	X	10.000 Ø	Z ₀ 0.000
F: 0	Z ₀	0.000	Z 0.000
0:00	Z		
mm	Face part then press Note or enter the tool position.		
Set			
1			

Note Calc Help

To set a datum manually:

- ▶ Press the **Datum** soft key
- ▶ Enter the **Datum Number**
- ▶ Highlight the **X** axis field
- ▶ Touch the workpiece at point **1**
- ▶ Press the **Note** soft key
- or
- ▶ Enter the radius or diameter of the workpiece at that point



Remember to ensure the product is in diameter display mode Ø if you input a diameter value.

- ▶ Highlight the **Z** axis field
- ▶ Touch the workpiece surface at point **2**
- ▶ Press the **Note** soft key
- or
- ▶ Enter the position of the tool tip (Z= 0) for the Z coordinate of the datum
- ▶ Press the **enter** key

10.4.2 Setting a datum using the Note function

The **Note** function is useful for setting a datum when a tool is under load, and the diameter of the workpiece is not known.

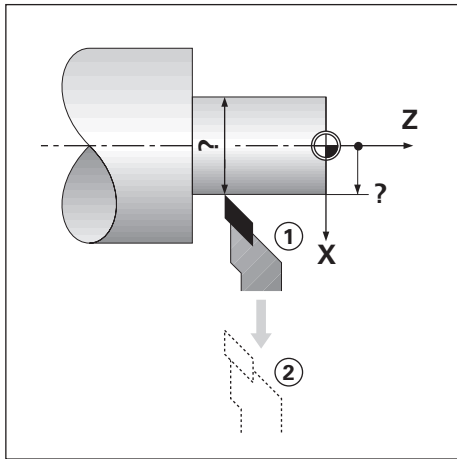

Datum		Position	
Datum Number	<input type="text" value="0"/>	X	<input type="text" value="0.000"/> Ø
X	<input type="text" value="Ø"/>	Z ₀	<input type="text" value="0.000"/>
Z ₀	<input type="text"/>	Z	<input type="text" value="0.000"/>
Z	<input type="text"/>		
Turn diameter then press Note or enter the tool position.			

Note Calc Help

To set a datum using the **Note** function

- ▶ Press the **Datum** soft key
- ▶ Enter the **Datum Number**
- ▶ Highlight the **X** axis field
- ▶ Turn a diameter in the X axis
- ▶ Press the **Note** soft key while the tool is still cutting
- ▶ Retract from the current position
- ▶ Turn the spindle off, and measure the workpiece diameter
- ▶ Enter the measured diameter, for example, 40 mm
- ▶ Press the **enter** key

10.5 Taper Calculator

Use the **Taper Calculator** to calculate taper angle.

Calculate tapers by entering dimensions from a print, or by touching a tapered workpiece with a tool.

Calculating a taper with known diameters and length

Taper Calculator		Position	
Diameter 1	10.0000	X	0.000 Ø
Diameter 2	12.0000	Z ₀	0.000
Length	20.0000	Z	0.000
Angle	2.8624°		

Requirements for taper calculation using diameters (**Diameter 1**, **Diameter 2**) and **Length**:

- Starting diameter
- End diameter
- Length of the taper

To calculate a taper with the known diameters and length:

- ▶ Press the **Calc** soft key
- > The soft key selections change to include taper calculator functions
- ▶ Press the **Taper: D1/D2/L** soft key
- ▶ Enter the first diameter in the **Diameter 1** field and press the **enter** key
or
- ▶ Touch the tool to one point and press the **Teach** soft key
- ▶ Enter the second diameter in the **Diameter 2** field and press the **enter** key
or
- ▶ Touch the tool to the second point and press the **Teach** soft key
The taper angle is automatically calculated when using the **Teach** soft key
- ▶ When entering data with the numeric keypad, enter the **Length**
- ▶ Press the **enter** key
- > The taper angle will appear in the **Angle** field

Calculating a taper with known change in radius and length

Taper Calculator		Position	
Entry 1	1.0000	X	0.000 \emptyset
Entry 2	8.0000	Z ₀	0.000
Ratio	1 : 8.0000	Z	0.000
Angle	7.1250°		

0:00
mm
Set
1

Help

Taper ratio calculation requirements:

- Change in the radius of the taper
 - Length of the taper
- To calculate a taper using the change in radius and length of the taper:
- ▶ Press the **Calc** soft key
 - > The soft key selections change to include taper calculator functions
 - ▶ Press the **Taper: Ratio** soft key
 - ▶ Enter the change in radius across the taper into the **Entry 1** field
 - ▶ Highlight the **Entry 2** field
 - ▶ Enter the length across the taper into the **Entry 2** field
 - ▶ Press the **enter** key
 - > The calculated **Ratio** and **Angle** will be displayed in their respective fields.

10.6 Presets

Preset functionality has been explained previously in this manual.

Further information: "Presetting a target position", Page 103

The explanation, and examples on those pages are based on a mill application. The basics of those explanations are the same for turning applications with two exceptions; Tool Diameter Offsets (R+/-), and Radius vs. Diameter inputs.

Tool diameter offsets have no applications with turning tools, so this functionality is not available while doing turning presets.

Input values can be either radius or diameter values. It is important to be sure the units you are entering for the preset agree with the state that the display is currently using. A diameter value is shown with a \emptyset symbol. The state of the display can be changed using the **Rad/Dia** soft key (available in both operating modes).

10.7 Diameter and radius measurements

Drawings for lathe parts usually give diameter values. The product can display either the diameter or the radius. When the diameter is being displayed, the diameter symbol \emptyset is shown next to the position value.

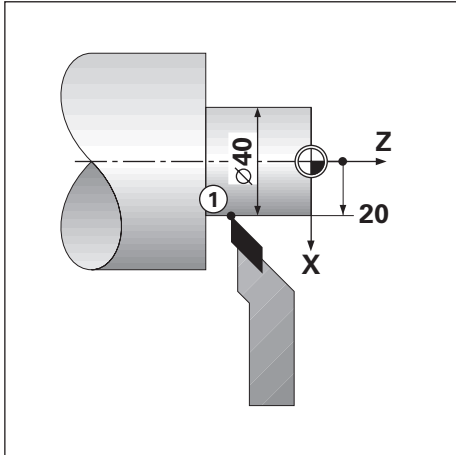

Example:

- Radius display, position 1, X = 20
- Diameter display, position 1, X = $\emptyset 40$

Activating diameter and radius measurements for an axis

Further information: "Diameter Axes", Page 86

Switching between radius and diameter measurements



The **Rad/Dia** soft key is only available when the **Application** is set to **Turn**.

Further information: "Readout Settings", Page 77

To toggle between radius and diameter measurements:

- ▶ Press the **Rad/Dia** soft key

10.8 Vectoring

Vectoring breaks down the movement of the compound axis into the crossfeed or longitudinal axes. If you are turning threads, for example, vectoring lets you see the diameter of the thread in the X-axis display, even though you are moving the cutting tool with the compound axis handwheel. With vectoring enabled, you can preset the desired radius or diameter in the X-axis, so that you can “machine to zero”.

i When vectoring is used, the top slide (compound) axis encoder must be assigned to the bottom display axis. The crossfeed component of movement of the axis will then be shown in the top display axis. The longitudinal component of movement of the axis will be shown in the middle display axis.

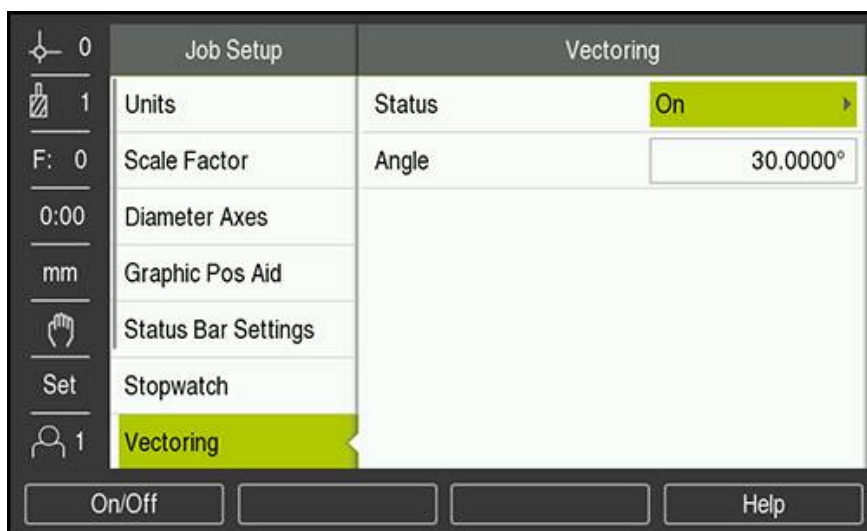

To enable vectoring:

- ▶ Press the **Setup** soft key
- ▶ Open in the sequence
 - **Job Setup**
 - **Vectoring**
- ▶ Press the **On/Off** soft key and select **On** to enable **Vectoring**
- ▶ Highlight the **Angle** field
- ▶ Enter the angle between the longitudinal slide and top slide with 0° indicating the top slide is moving parallel to the longitudinal slide
- ▶ Press the **enter** key to save the **Vectoring** parameter changes and return to the **Job Setup** menu

10.9 Z coupling

The **Turn** application provides a quick method for coupling the Z_0 and Z axes positions on a 3 axis system. The display can be coupled in either the Z_0 or Z displays.

Moving either Z_0 or Z inputs will update the coupled Z position.

The coupling is preserved in between power cycles.



The reference mark for both encoders must be found in order to recall the previous datum when a position is coupled.

Display the coupled position on the Z_0 axis

To couple the Z_0 and Z axes, and have the result displayed on the Z_0 display:

- ▶ Press and hold the Z_0 key approximately 2 seconds
- > The sum of the Z positions will be displayed on the Z_0 display and the Z display will be blank

Display the coupled position on the Z axis

To couple the Z_0 , and Z axes and have the result displayed on the Z display:

- ▶ Press and hold the Z key for approximately 2 seconds
- > The sum of the Z positions will be displayed on the Z display and the Z_0 display will be blank

Coupling the Z_0 and Z axes positions can also be done from the **Display Configuration** menu.

Further information: "Display Configuration", Page 76

Disabling Z coupling

To disable Z coupling:

- ▶ Press the axis key for the display that is blank
- > The Z_0 and Z displays will be restored

11

External operation

11.1 External operation

The product can be operated over the USB data interface from a host application. Special commands available: <Ctrl>B 'Send Current Position', <Ctrl>P 'Send Screen Capture'.

The following key commands are available:

Format

<ESC>TXXXX<CR>	Key is pressed
<ESC>AXXXX<CR>	Output of screen contents
<ESC>SXXXX<CR>	Special functions

Sequence of commands

Function

<ESC>T0000<CR>	0 key
<ESC>T0001<CR>	1 key
<ESC>T0002<CR>	2 key
<ESC>T0003<CR>	3 key
<ESC>T0004<CR>	4 key
<ESC>T0005<CR>	5 key
<ESC>T0006<CR>	6 key
<ESC>T0007<CR>	7 key
<ESC>T0008<CR>	8 key
<ESC>T0009<CR>	9 key
<ESC>T0100<CR>	C key
<ESC>T0101<CR>	+/- key
<ESC>T0102<CR>	. (decimal) key
<ESC>T0104<CR>	enter key
<ESC>T0109<CR>	Axis Key 1
<ESC>T0110<CR>	Axis Key 2
<ESC>T0111<CR>	Axis Key 3
<ESC>T0114<CR>	Soft key 1
<ESC>T0115<CR>	Soft key 2
<ESC>T0116<CR>	Soft key 3
<ESC>T0117<CR>	Soft key 4
<ESC>T0135<CR>	Left arrow key
<ESC>T0136<CR>	Right arrow key
<ESC>T0137<CR>	Up arrow key
<ESC>T0138<CR>	Down arrow key
<ESC>A0000<CR>	Send device identification
<ESC>A0200<CR>	Send actual position
<ESC>S0000<CR>	Reset device
<ESC>S0001<CR>	Lock keypad
<ESC>S0002<CR>	Release keypad

12

Reference tables

12.1 Drill sizes to decimal inches

Size	Inches
1.00 mm	0.0394
60	0.0400
59	0.0410
1.05 mm	0.0413
58	0.0420
57	0.0430
1.10 mm	0.0433
1.15 mm	0.0453
56	0.0465
3/64	0.0469
1.20 mm	0.0472
1.25 mm	0.0492
1.30 mm	0.0512
55	0.0520
1.35 mm	0.0531
54	0.0550
1.40 mm	0.0551
1.45 mm	0.0571
1.50 mm	0.0591
53	0.0595
1.55 mm	0.0610
1/16	0.0625
1.60 mm	0.0630
52	0.0635
1.65 mm	0.0650
1.70 mm	0.0669
51	0.0670
1.75 mm	0.0689
50	0.0700
1.80 mm	0.0728
49	0.0730
1.90 mm	0.0748
48	0.0760
1.95 mm	0.0768
5/64	0.0781
47	0.0785
2.00 mm	0.0787

Size	Inches
2.05 mm	0.0807
46	0.0810
45	0.0820
2.40 mm	0.0827
2.15 mm	0.0846
44	0.0860
2.20 mm	0.0866
2.25 mm	0.0886
43	0.0890
2.30 mm	0.0906
2.35 mm	0.0925
42	0.0935
3/32	0.0938
2.40 mm	0.0945
41	0.0960
2.45 mm	0.0965
40	0.0980
2.50 mm	0.0984
39	0.0995
38	0.1015
2.60 mm	0.1024
37	0.1040
2.70 mm	0.1063
36	0.1065
2.75 mm	0.1083
7/64	0.1094
35	0.1100
2.80 mm	0.1102
34	0.1110
33	0.1130
2.90 mm	0.1142
32	0.1160
3.00 mm	0.1181
31	0.1200
3.10 mm	0.1220
1/8	0.1250
3.20 mm	0.1260
3.25 mm	0.1280
30	0.1285

Size	Inches
3.30 mm	0.1299
3.40 mm	0.1339
29	0.1360
3.50 mm	0.1378
28	0.1405
9/64	0.1406
3.60 mm	0.1417
27	0.1440
3.70 mm	0.1457
26	0.1470
3.75 mm	0.1476
25	0.1495
3.80 mm	0.1495
24	0.1520
3.90 mm	0.1535
23	0.1540
5/32	0.1562
22	0.1570
4.00 mm	0.1575
21	0.1590
20	0.1610
4.10 mm	0.1614
4.20 mm	0.1654
19	0.1660
4.25 mm	0.1673
4.30 mm	0.1693
18	0.1695
44/64	0.1719
17	0.1730
4.40 mm	0.1732
16	0.1770
4.50 mm	0.1772
15	0.1800
4.60 mm	0.1811
14	0.1820
13	0.1850
4.70 mm	0.1850
4.75 mm	0.1870
3/16	0.1875

Size	Inches
4.80 mm	0.1890
12	0.1890
11	0.1910
4.90 mm	0.1929
10	0.1935
9	0.1960
5.00 mm	0.1969
8	0.1990
5.10 mm	0.2008
7	0.2010
13/64	0.2031
6	0.2040
5.20 mm	0.2047
5	0.2055
5.25 mm	0.2067
5.30 mm	0.2087
4	0.2090
5.40 mm	0.2126
3	0.2130
5.50 mm	0.2165
7/32	0.2188
5.60 mm	0.2205
2	0.2211
5.70 mm	0.2244
5.75 mm	0.2264
1	0.2280
5.80 mm	0.2283
5.90 mm	0.2323
A	0.2340
15/64	0.2344
6.00 mm	0.2362
B	0.2380
6.10 mm	0.2402
C	0.2420
6.20 mm	0.2441
D	0.2460
6.25 mm	0.2461
6.30 mm	0.2480
E	0.2500

Size	Inches
1/4	0.2500
6.40 mm	0.2520
6.50 mm	0.2559
F	0.2570
6.60 mm	0.2598
G	0.2610
6.70 mm	0.2638
17/64	0.2656
6.75 mm	0.2657
H	0.2660
6.80 mm	0.2677
6.90 mm	0.2717
I	0.2720
7.00 mm	0.2756
J	0.2770
7.10 mm	0.2795
K	0.2810
9/32	0.2812
7.20 mm	0.2835
7.25 mm	0.2854
7.30 mm	0.2874
L	0.2900
7.40 mm	0.2913
M	0.2950
7.50 mm	0.2953
19/64	0.2969
7.60 mm	0.2992
N	0.3020
7.70 mm	0.3031
7.75 mm	0.3051
7.80 mm	0.3071
7.90 mm	0.3110
5/16	0.3125
8.00 mm	0.3150
O	0.3160
8.10 mm	0.3189
8.20 mm	0.3228
P	0.3230
8.25 mm	0.3248

Size	Inches
8.30 mm	0.3268
21/64	0.3281
8.40 mm	0.3307
Q	0.3320
8.50 mm	0.3346
8.60 mm	0.3386
R	0.3390
8.70 mm	0.3425
11/32	0.3438
8.75 mm	0.3445
8.80 mm	0.3465
S	0.3480
8.90 mm	0.3504
9.00 mm	0.3546
T	0.3580
9.10 mm	0.3583
23/64	0.3594
9.20 mm	0.3622
9.25 mm	0.3642
9.30 mm	0.3661
U	0.3680
9.40 mm	0.3740
9.50 mm	0.3740
3/8	0.3750
V	0.3770
9.60 mm	0.3780
9.70 mm	0.3819
9.75 mm	0.3839
9.80 mm	0.3858
W	0.3860
9.90 mm	0.3898
25/64	0.3906
10.00 mm	0.3937
X	0.3970
Y	0.4040
13/32	0.4062
Z	0.4130
10.50 mm	0.4134
27/64	0.4219

Size	Inches
11.00 mm	0.4331
7/16	0.4375
11.50 mm	0.4528
29/64	0.4531
15/32	0.4688
12.00 mm	0.4724
31/64	0.4844
12.50 mm	0.4921
1/2	0.5000
13.00 mm	0.5118
33/64	0.5156
17/32	0.5312
13.50 mm	0.5315
35/64	0.5469
14.00 mm	0.5512
9/16	0.5625
14.50 mm	0.5709
37/64	0.5781
15.00 mm	0.5906
19/32	0.5938
39/64	0.6094
15.50 mm	0.6102
5/8	0.6250
16.00 mm	0.6299
41/64	0.6406
16.50 mm	0.6496
21/32	0.6562
17.00 mm	0.6693
43/64	0.6719
11/16	0.6875
17.50 mm	0.6890
45/64	0.7031
18.00 mm	0.7087
23/32	0.7188
18.50 mm	0.7283
47/64	0.7344
19.00 mm	0.7480
3/4	0.7500
49/64	0.7656

Size	Inches
19.50 mm	0.7677
25/32	0.7812
20.00 mm	0.7874
51/64	0.7969
20.50 mm	0.8071
13/16	0.8125
21.00 mm	0.8268
27/32	0.8438
21.50 mm	0.8465
55/64	0.8594
22.00 mm	0.8661
7/8	0.8750
22.50 mm	0.8858
57/64	0.8906
23.00 mm	0.9055
29/32	0.9062
59/64	0.9219
23.50 mm	0.9252
15/16	0.9375
24.00 mm	0.9449
61/64	0.9531
24.50 mm	0.9646
31/32	0.9688
25.00 mm	0.9843
63/64	0.9844
1	1.0000

12.2 English tap drill sizes

Tap	Drill
2-56	50
2-64	50
4-40	43
4-48	42
6-32	36
6-40	33
8-32	29
8-36	29
10-24	26
10-32	21
1/4-20	7
1/4-28	3
5/16-18	F
5/16-24	I
3/8-16	5/16
3/8-24	Q
1/2-13	27/64
1/2-20	29/64
5/8-11	17/32
5/8-18	37/64
3/4-10	21/32
3/4-16	11/16
1-8	7/8
1-12	59/64

12.3 Metric tap drill sizes

Metric tap	Drill mm	~Drill inches
m1.5	1.25	-
m2	1.60	52
m3	2.50	40
m4	3.30	30
m5	4.20	19
m6	5.00	9
m8	6.70	17/64
m10	8.50	Q
m12	10.20	Y
m16	14.00	35/64
m20	17.50	11/16
m24	21.00	53/64

12.4 English recommended surface speeds

HSS

Material	BHN	ft/min
cast iron		
soft	120-220	100 - 80
medium	190-220	80 - 60
hard	220-260	60 - 30
crs & hrs*	100-275	110 - 65
soft alloy	125-225	100 - 90
hard alloy	225-425	100 - 20
cast stl	125-300	95 - 60
aluminum		800 - 500
brass		500 - 300
bronze		140 - 80
magnesium		-

*most low & medium carbon

Carbide

Material	BHN	ft/min
cast iron		
soft	120-220	400 - 360
medium	190-220	380 - 240
hard	220-260	240 - 120
crs & hrs*	100-275	440 - 260
soft alloy	125-225	400 - 360
hard alloy	225-425	400 - 80
cast stl	125-300	380 - 240
aluminum		1800 - 1000
brass		1000 - 600
bronze		275 - 180
magnesium		3000 - 500

*most low & medium carbon

12.5 Metric recommended surface speeds

HSS

Material	BHN	m/min
cast iron		
soft	120-220	30 - 25
medium	190-220	25 - 20
hard	220-260	20 - 10
crs & hrs*	100-275	35 - 20
soft alloy	125-225	30 - 28
hard alloy	225-425	30 - 6
cast stl	125-300	29 - 18
aluminum		240 - 150
brass		150 - 90
bronze		40 - 25
magnesium		-

*most low & medium carbon

Carbide

Material	BHN	m/min
cast iron		
soft	120-220	120 - 110
medium	190-220	115 - 70
hard	220-260	70 - 40
crs & hrs*	100-275	135 - 80
soft alloy	125-225	120 - 110
hard alloy	225-425	120 - 25
cast stl	125-300	115 - 70
aluminum		545 - 300
brass		300 - 180
bronze		80 - 55
magnesium		910 - 150

*most low & medium carbon

13

Settings

13.1 Overview

This chapter describes the settings options and the associated parameters for the product.

The basic settings options and parameters for commissioning are outlined in the respective chapter:

Further information: "Commissioning", Page 65

Function	Description
Job Setup	Set the individual job properties
Installation Setup	Set the installation setup properties

Activation

- ▶ Press the **Setup** soft key

13.2 Factory default settings

If individual settings that were changed during commissioning need to be reset to the default setting, you can look up the default for each adjustment parameter in this chapter.

If all settings need to be reset, you can restore the product to the default settings.

Further information: "Factory defaults", Page 79

13.3 Job Setup

13.3.1 Units

Units settings are used to set the working units of measure for linear and angular dimensions.

Parameter	Explanation
Linear	The unit of measure used for linear measurements <ul style="list-style-type: none"> ■ inch or mm ■ Default setting: mm
Angular	The unit of measure used for angular measurements <ul style="list-style-type: none"> ■ Decimal Degrees, Radians, DMS ■ Default setting: Decimal Degrees

13.3.2 Scale Factor

Scale Factor is used to scale a part up or down.

Parameter	Explanation
Any assigned display label ex. X , Y , or Z	<ul style="list-style-type: none"> ■ Off or On ■ Default setting: Off

13.3.3 Diameter Axes

Diameter Axes settings are used to set which display positions can be displayed as diameter values.

Parameter	Explanation
Any assigned display label ex. X , Y , or Z	<ul style="list-style-type: none"> ■ Off or On ■ Default setting: Off

13.3.4 Graphic Pos Aid

Graphic Pos Aid settings are used to turn the graphic positioning display on or off, and set it's range.

Parameter	Explanation
Any assigned display label ex. X , Y , or Z	Turn the graphic positioning display on or off <ul style="list-style-type: none"> ■ Off, On, or enter a range ■ Default range setting: 5.000 mm

13.3.5 Status Bar Settings

Status Bar Settings are used to select which features are displayed in the Status Bar.

Parameter	Explanation
Datum	<ul style="list-style-type: none"> ■ Off or On ■ Default setting: On
Tool	<ul style="list-style-type: none"> ■ Off or On ■ Default setting: On
Feed Rate	Displayed in inch/min or mm/min depending on the selected unit of measure. <ul style="list-style-type: none"> ■ Off or On ■ Default setting: On
Stop Watch	<ul style="list-style-type: none"> ■ Off or On ■ Default setting: On
Current User	<ul style="list-style-type: none"> ■ Off or On ■ Default setting: On

13.3.6 Stopwatch

Stopwatch settings are used to operate the **Stopwatch**.

Parameter	Explanation
Status	Displays the current state <ul style="list-style-type: none"> Settings: Stopped or Running Default setting: Stopped
Elapsed Time	Displays the elapsed time that the stopwatch has been running <ul style="list-style-type: none"> Default setting: 00:00:00

13.3.7 Display Settings

Display Settings are used to adjust the appearance of the display.

Parameter	Explanation
Brightness	Set the brightness of the display <ul style="list-style-type: none"> Setting range: 10 % ... 100 % Default setting: 90 %
Display Saver (min)	Set how long the display can remain inactive, in minutes, before the display saver turns on <ul style="list-style-type: none"> Settings: Off, 10, 30 Default setting: 30
Color Mode	Set the color mode for varying ambient lighting conditions <ul style="list-style-type: none"> Settings: Night or Day Default setting: Day
Axes Displays	Set how the axis that is in motion is displayed <ul style="list-style-type: none"> Off Dynamic Zoom: The axis currently in motion is magnified on the display Highlight: The axis currently in motion is highlighted on the display. All other axes are grayed out. Default setting: Off
Zoom Timeout (sec)	Enter the time, in seconds, Dynamic Zoom or Highlight stays active after axis movement stops <ul style="list-style-type: none"> Setting range: 1 ... 10 Default value: 1
Axes Label Position	Set which side of the display the axis labels appear <ul style="list-style-type: none"> Settings: Left or Right Default setting: Right

13.3.8 Vectoring

Vectoring settings are used to enable and configure the **Vectoring** feature.

Parameter	Explanation
Status	Enable or disable the Vectoring feature <ul style="list-style-type: none">■ Off or On■ Default setting: Off
Angle	Set the angle between the longitudinal slide and the top slide <ul style="list-style-type: none">■ Setting range: 0° - 360°

13.3.9 Language

The **Language** setting is used to select the language used for the user interface.

Parameter	Explanation
Language	<ul style="list-style-type: none">■ Settings: multiple languages■ Default setting: English

13.4 Installation Setup

13.4.1 File Management

File Management options are used to import, export, and install files on the product.

Parameter	Explanation
Configuration Parameters	Import or export a Configuration Parameters file <ul style="list-style-type: none"> Options: Import or Export
Segmented LEC Table	Import or export a Segmented LEC Table file <ul style="list-style-type: none"> Options: Import or Export
Tool Table	Import or export a Tool Table file <ul style="list-style-type: none"> Options: Import or Export
Operating Instructions	Install an Operating Instructions file <ul style="list-style-type: none"> Options: Load
Power-up Screen	Import or export a Power-up Screen file <ul style="list-style-type: none"> Options: Import or Export
Service File	Clear or export a Service File <ul style="list-style-type: none"> Options: Clear or Export
Product Software	Install a Product Software file <ul style="list-style-type: none"> Options: Install

13.4.2 Encoder Setup

Encoder settings are used to configure parameters for each encoder.

Parameter	Explanation
Encoder Type	<ul style="list-style-type: none"> Settings: Linear, Rotary, or Rotary (Linear) Default setting: Linear
Resolution	<ul style="list-style-type: none"> Settings: varies based on Encoder Type
Reference Mark	<ul style="list-style-type: none"> Settings: None, Single, Coded / 1000, Coded / 2000, Position Trac, P-Trac (ENC 250) Default setting: varies based on Encoder Type
Count Direction	<ul style="list-style-type: none"> Settings: Negative or Positive Default setting: Positive
Error Monitor	<ul style="list-style-type: none"> Off or On Default setting: On

13.4.3 Display Configuration

Display settings are used to configure the resolution, labels, and inputs shown on the display.

Parameter	Explanation
Display Resolution	Settings vary based on encoder connected to the product
Label	<ul style="list-style-type: none"> ■ Settings: Off, X, Y, Z, U, V, W, A, B, C, S ■ Default Setting: <ul style="list-style-type: none"> ■ Display 1: X ■ Display 2: Y ■ Display 3: Z
Subscript	<ul style="list-style-type: none"> ■ Settings: Off or On ■ Default Setting: Off
Input 1	<ul style="list-style-type: none"> ■ Settings: X1, X2, X3 ■ Default Setting: <ul style="list-style-type: none"> ■ Display 1: X1 ■ Display 2: X2 ■ Display 3: X3
Couple Operation	<ul style="list-style-type: none"> ■ Settings: +, -, Off ■ Default Setting: Off
Input 2	<ul style="list-style-type: none"> ■ Settings: Not Defined, X1, X2, X3 ■ Default Setting: Not Defined

13.4.4 Readout Settings

Readout Settings are used to configure the **Application**, **Number of Axes**, and **Position Recall**.

Parameter	Explanation
Application	<ul style="list-style-type: none"> ■ Settings: Mill or Turn ■ Default Setting: Mill
Number of Axes	<ul style="list-style-type: none"> ■ Settings: 1, 2, 3 ■ Default Setting: 3
Position Recall	<ul style="list-style-type: none"> ■ Settings: Off or On ■ Default Setting: Off

13.4.5 Diagnostics

Diagnostics are used to test the keypad and the display.

Further information: "Diagnostics", Page 78

13.4.6 Display Color Scheme

The **Display Color Scheme** settings are used to select the **Color Mode** of the display and to set whether users can select the **Color Mode**.

Parameter	Explanation
Color Mode	<ul style="list-style-type: none"> ■ Settings: Day, Night, User Selectable ■ Default Setting: User Selectable

13.4.7 Factory Defaults

The **Factory Defaults** option is used to reset **Job Setup** and **Installation Setup** parameters to the default settings.

Parameter	Explanation
Reset Settings	<ul style="list-style-type: none"> ■ Settings: No or Yes ■ Default Setting: No

13.4.8 Error Compensation

Error Compensation provides a way to configure Linear, or Segmented Linear Error Compensation for each encoder.

Parameter	Explanation
X1, X2, X3	Settings: Off, Linear, Segmented Default setting: Off

13.4.9 Backlash compensation

Backlash Comp. is used to activate backlash compensation for rotary encoders.

Parameter	Explanation
X1, X2, X3	<ul style="list-style-type: none"> ■ Settings: Off, On ■ Default setting: Off

14

**Service and
maintenance**

14.1 Overview

This chapter describes the general maintenance work on the product:



This chapter contains a description of maintenance work for the product only.

Further Information: Manufacturer's documentation for the respective peripheral devices

14.2 Cleaning

NOTICE

Cleaning with sharp-edged objects or aggressive cleaning agents

Improper cleaning will cause damage to the product.

- ▶ Never use abrasive or aggressive cleaners, and never use strong detergents or solvents
 - ▶ Do not use sharp-edged objects to remove persistent contamination
-
- ▶ Use only a cloth dampened with water and a mild detergent for cleaning the exterior surfaces
 - ▶ Use a lint-free cloth and a commercially available glass cleaner to clean the screen

14.3 Maintenance schedule

The product is largely maintenance-free.

NOTICE

Operating defective products

Operating defective products may result in serious consequential damage.

- ▶ Do not operate or repair the product if damaged
- ▶ Replace defective products immediately or contact an authorized service agency



The following steps are only to be performed by electrical specialists.

Further information: "Personnel qualification", Page 21

Personnel requirement

Maintenance step	Interval	Corrective action
▶ Check all labels and symbols provided on the product for readability	Annually	▶ Contact an authorized service agency
▶ Inspect electrical connections for damage and check their function	Annually	▶ Replace defective cables. Contact an authorized service agency if required.
▶ Check power cables for faulty insulation and weak points	Annually	▶ Replace power cables according to the specification

14.4 Resuming operation

When operation is resumed, e.g. when the product is reinstalled after repair or when it is remounted, the same measures and personnel requirements apply as for mounting and installing the product.

Further information: "Mounting", Page 29

Further information: "Installation", Page 35

When connecting the peripheral devices (e.g. encoders), the operating company must ensure safe resumption of operation and assign authorized and appropriately qualified personnel to the task.

Further information: "Obligations of the operating company", Page 22

14.5 Resetting to the factory defaults

You can reset the settings of the product to the factory defaults, if required.

- ▶ Press the **Setup** soft key
- ▶ Use the arrow keys to select the sequence
 - **Installation Setup**
 - **Factory Defaults**
 - **Reset Settings**
 - **Yes**
- ▶ Press the **enter** key

15

What to do if...

15.1 Overview

This chapter describes the causes of faults or malfunctions of the product and the appropriate corrective actions.

i Make sure that you have read and understood the "Basic Operation" chapter before performing the activities described in this section.

Further information: "Basic operation", Page 49

15.2 Malfunctions

If faults or malfunctions that are not listed in the "Troubleshooting" table below occur during operation, refer to the machine tool builder's documentation or contact an authorized service agency.

15.3 Troubleshooting

i The following troubleshooting steps must be performed only by the personnel indicated in the table.

Further information: "Personnel qualification", Page 21

Fault	Cause of fault	Correction of fault	Personnel
Status LED remains dark after switch-on.	There is no supply voltage	▶ Check the power cable	Electrical specialist
	The product does not function properly	▶ Contact an authorized service agency	Qualified personnel
The position display does not count the axis position even though the encoder is moving.	Incorrect connection of the encoder	▶ Correct the connection ▶ Contact the encoder manufacturer's service agency	Qualified personnel
The position display miscounts the axis position.	Incorrect settings of the encoder	▶ Check the encoder settings Page 152	Qualified personnel
The connected USB mass storage device is not detected.	Defective connection	▶ Check the correct position of the USB mass storage device in the port	Qualified personnel
	The type or formatting of the USB mass storage device is not supported	▶ Use another USB mass storage device	Qualified personnel

16

**Removal and
disposal**

16.1 Overview

This chapter provides information about the removal and disposal of the product. This information includes requirements to be complied with in respect of environmental-protection laws.

16.2 Removal



Removal of the product is to be performed only by qualified personnel.

Further information: "Personnel qualification", Page 21

Depending on the connected peripherals, the removal may need to be performed by an electrical specialist.

In addition, the same safety precautions that apply to the mounting and installation of the respective components must be taken.

Removing the product

To remove the product, follow the installation and mounting steps in the reverse order.

Further information: "Installation", Page 35

Further information: "Mounting", Page 29

16.3 Disposal



NOTICE

Incorrect disposal of the product!

Incorrect disposal of the product can cause environmental damage.

- ▶ Do not dispose of electrical waste and electronic components in domestic waste
- ▶ The integrated backup battery must be disposed of separately from the product
- ▶ Forward the product and the backup battery to recycling in accordance with the applicable local disposal regulations

- ▶ If you have any questions about the disposal of the product, please contact a HEIDENHAIN service agency

17

Specifications

17.1 Product specifications

Product

Housing	Die cast aluminum
Housing dimensions	285 mm x 180 mm x 41 mm
Fastener system, mating dimensions	VESA MIS-D, 100 100 mm x 100 mm

Display

Visual display unit	<ul style="list-style-type: none"> ■ LCD Widescreen (15:9) color screen 17.8 cm (7") ■ 800x 480 pixels
User interface	Graphical user interface (GUI) with keypad

Electrical data

Power supply	<ul style="list-style-type: none"> ■ AC 100 V ... 240 V ($\pm 10\%$) ■ 50 Hz ... 60 Hz ($\pm 5\%$) ■ Input power max. 30 W
Buffer battery	Lithium battery type CR2032; 3.0 V
Overvoltage category	II
Number of encoder inputs	3
Encoder interfaces	TTL: Max. current 300 mA max. input frequency 500 kHz
Data interface	USB 2.0 Hi-Speed (Type C), max. current 500 mA

Ambient conditions

Operating temperature	0 °C ... 45 °C
Storage temperature	-20 °C ... 70 °C
Relative air humidity	10 % ... 80 % r.H., non-condensing
Altitude	≤ 2000 m

General information

Directives	<ul style="list-style-type: none"> ■ EMC Directive 2014/30/EU ■ Low Voltage Directive 2014/35/EU ■ RoHS Directive 2011/65/EU
Pollution degree	2
Protection EN 60529	<ul style="list-style-type: none"> ■ Front panel and side panels: IP 54 ■ Rear panel: IP 40

General information

- Mass
- 1.7 kg
 - With Single-Pos stand: 1.8 kg
 - With Multi-Pos holder: 2.1 kg
 - With Mounting frame: 3.1 kg

17.2 Product dimensions and mating dimensions

All dimensions in the drawings are in millimeters.

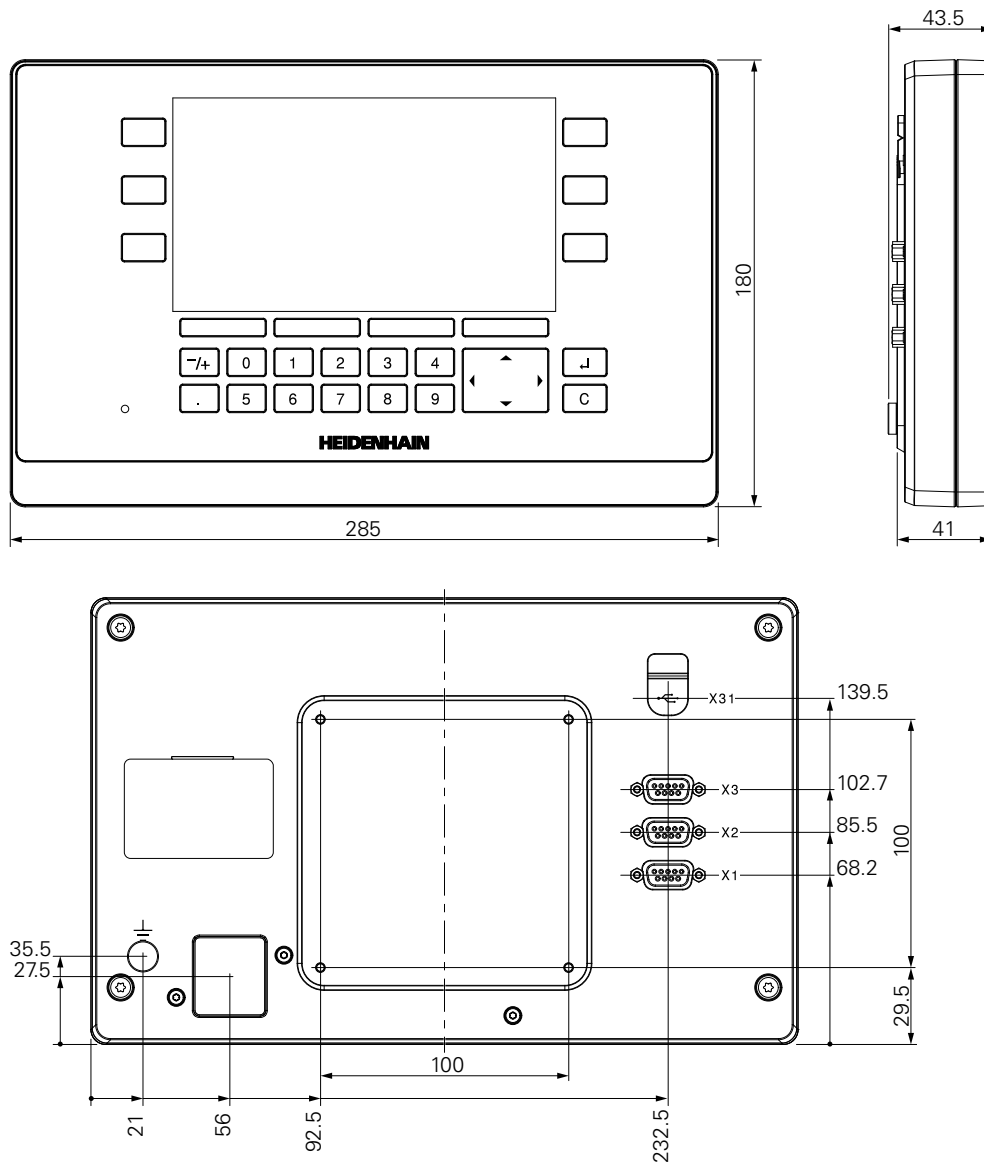

Product dimensions with Single-Pos stand

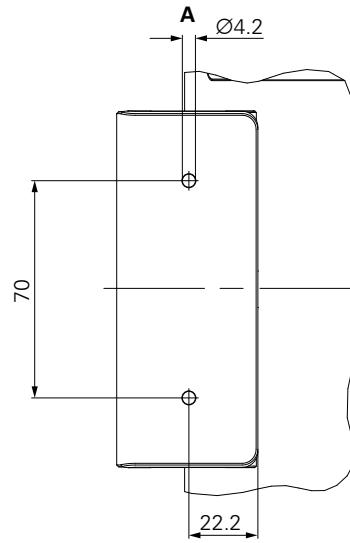
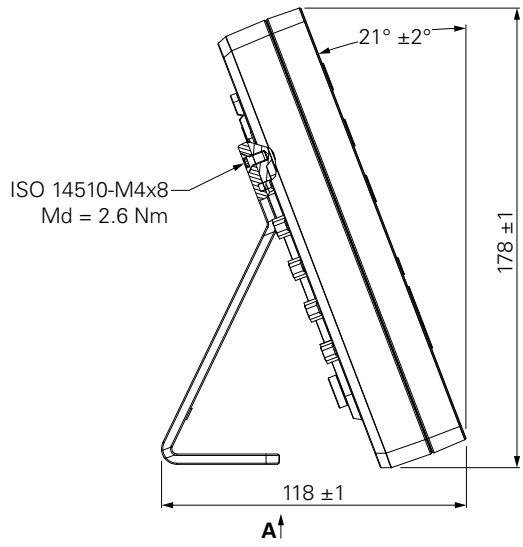

Product dimensions with Multi-Pos holder

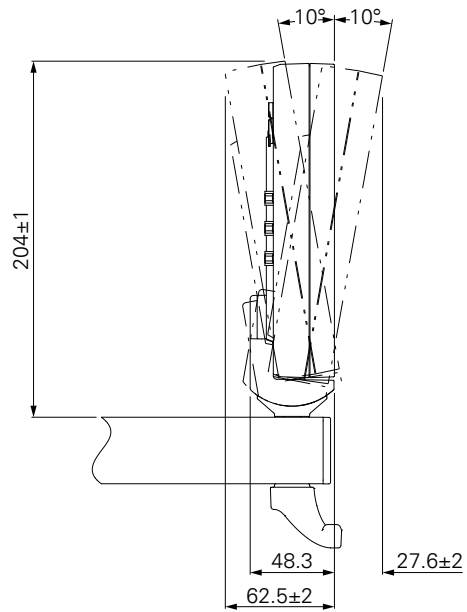

Product dimensions with mounting frame

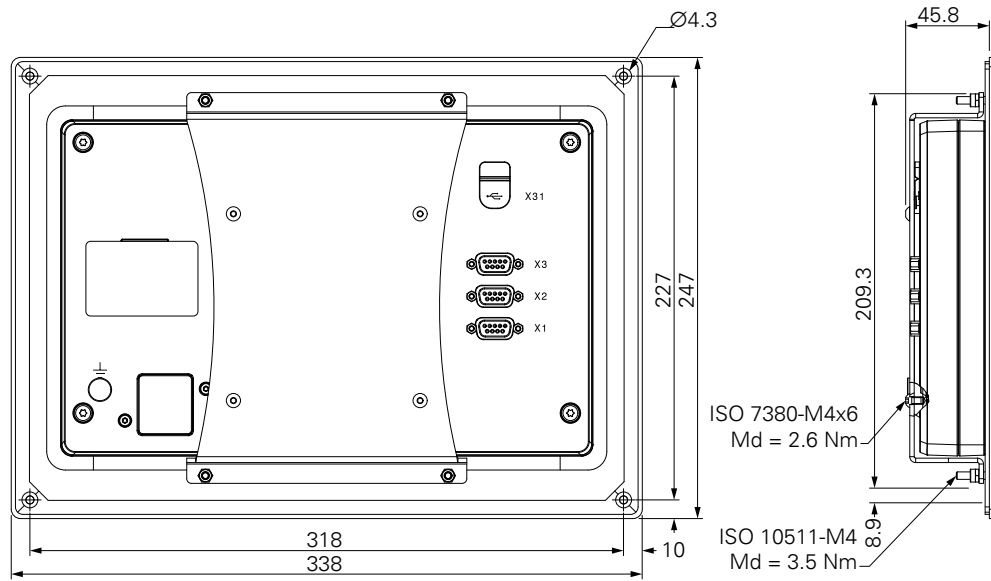

HEIDENHAIN

DR. JOHANNES HEIDENHAIN GmbH

Dr.-Johannes-Heidenhain-Straße 5

83301 Traunreut, Germany

☎ +49 8669 31-0

☎ +49 8669 32-5061

info@heidenhain.de

Technical support ☎ +49 8669 32-1000

Measuring systems ☎ +49 8669 31-3104

service.ms-support@heidenhain.de

NC support ☎ +49 8669 31-3101

service.nc-support@heidenhain.de

NC programming ☎ +49 8669 31-3103

service.nc-pgm@heidenhain.de

PLC programming ☎ +49 8669 31-3102

service.plc@heidenhain.de

APP programming ☎ +49 8669 31-3106

service.app@heidenhain.de

www.heidenhain.com

