



RSF Elektronik

www.rsf.at

MC 15 ABSOLUTE EXPOSED LINEAR ENCODERS





- Absolute Position valuation
- Large mounting tolerances
- Serial interfaces
- Status display directly at the scanning head via LED function

ABSOLUTE MEASUREMENT PRINCIPLE

This means the position valuation from evaluating one unique code information at any point over the entire measuring length. For this the scanning head needs not to be moved relative to the graduation carrier, so that the position value is available immediately after power-on. Reference points and reference drives are thus not required. The subsequent electronics may access this position value at any time.

REQUIREMENTS ON AN ABSOLUTE LINEAR ENCODER

- AVOIDING REFERENCING
- ADVANCED OPERATIONAL SAFETY
- HIGH TRAVERSING SPEED
- SMALL DIMENSIONS
- NO MECHANICAL BACKLASH
- ZERO FRICTIONAL FORCE
- WEAR-FREE OPERATION

TERM EXPLANATIONS

Absolute position indexing

Serial encoding of a line sequence as a highly precise graduation.

Scanning head

Opto-electronic scanning device of a graduation.

Yaw angle, pitch angle, roll angle, displacement, gap tolerance

Mounting tolerances of the scanning head relative to the graduation carrier.

Accuracy

This is a fundamental characteristic, which is specified with an accuracy grade (e.g. $\pm 5 \mu\text{m}/\text{m}$).

Measuring step

The smallest digital counting step produced by an encoder.

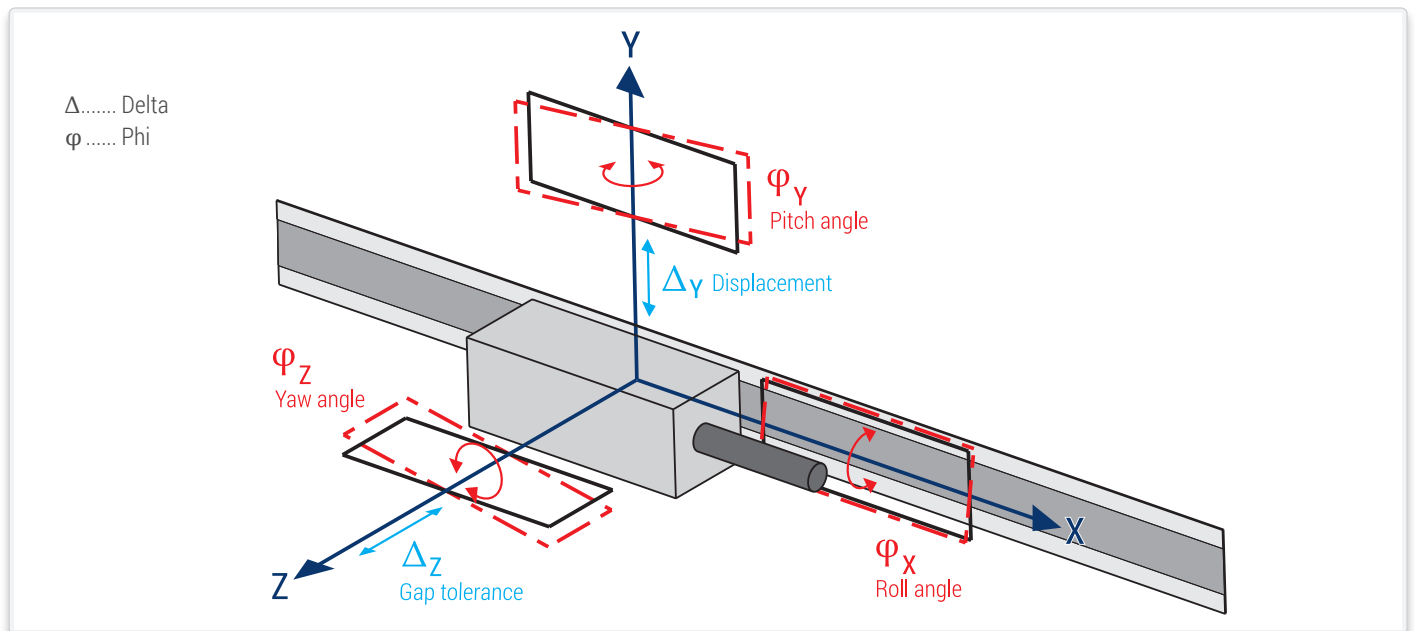

PIN ASSIGNMENTS

Coupling M12, male, 8-pin according to IEC 61076-2-101 LM008-Gxx-A



D-sub connector, male, 15-pin



EnDat 2.2	Voltage supply				Absolute position values			
	8	2	5	1	3	4	7	6
	4	12	2	10	5	13	8	15
EnDat 2.2	Up	Sensor Up	0 V	Sensor 0 V	DATA	$\overline{\text{DATA}}$	CLOCK	$\overline{\text{CLOCK}}$
	Brown/Green	Blue	White/Green	White	Grey	Pink	Violet	Yellow

BiSS C

	8	2	5	1	3	4	7	6
	4	12	2	10	5	13	8	15
BiSS/Cu	Up	Sensor Up	0 V	Sensor 0 V	SLO+	SLO-	MA+	MA-
	Brown/Green	Blue	White/Green	White	Grey	Pink	Violet	Yellow

Fanuc

	8	2	5	1	3	4	7	6
	4	12	2	10	5	13	8	15
Fanuc05 ai Interface	Up	Sensor Up	0 V	Sensor 0 V	Serial Data	$\overline{\text{Serial Data}}$	Request	$\overline{\text{Request}}$
	Brown/Green	Blue	White/Green	White	Grey	Pink	Violet	Yellow

Mitsubishi

	8	2	5	1	3	4	7	6
	4	12	2	10	5	13	8	15
Mit03-4	Up	Sensor Up	0 V	Sensor 0 V	Serial Data	$\overline{\text{Serial Data}}$	Request Frame	$\overline{\text{Request Frame}}$
Mit03-2					Occupied *	Occupied *	Request/ Data	$\overline{\text{Request/ Data}}$
	Brown/Green	Blue	White/Green	White	Grey	Pink	Violet	Yellow

Panasonic

	8	2	5	1	3	4	7	6
	4	12	2	10	5	13	8	15
Pana02	Up	Sensor Up	0 V	Sensor 0 V	Occupied *	Occupied *	Request/ Data	$\overline{\text{Request/ Data}}$
	Brown/Green	Blue	White/Green	White	Grey	Pink	Violet	Yellow

Yaskawa

	8	2	5	1	3	4	7	6
	4	12	2	10	5	13	8	15
YEC07	Up	Sensor Up	0 V	Sensor 0 V	Occupied *	Occupied *	DATA	$\overline{\text{DATA}}$
	Brown/Green	Blue	White/Green	White	Grey	Pink	Violet	Yellow

- Up = Power supply voltage
- Sensor: The sensor line is connected in the scanning head with the corresponding power line.
- The shield is connected with the chassis.
- Not connected pins or wires must not be used.
- * Required for adjustment/inspection by PWT 101.

SERIAL INTERFACES

EnDat 2.2

The EnDat interface is a digital, **bidirectional** interface for encoders. It is capable both of transmitting **position values** as well as transmitting or updating information stored in the encoder, or of saving new information. Thanks to the **serial transmission method**, only **four signal lines** are required. The data is transmitted in **synchronism** with the clock signal from the subsequent electronics. The type of transmission (position values, parameters, diagnostics, etc.) is selected through mode commands that the subsequent electronics send to the encoder.

CLOCK FREQUENCY

The clock frequency is variable—depending on the cable length (max. 150 m)—between 100 kHz and 2 MHz. With propagation-delay compensation in the subsequent electronics, either clock frequencies up to 16 MHz are possible or cable lengths up to 100 m. The maximum clock frequency is stored in the encoder memory.

EnDat 2.2	≤ 8 MHz or 16 MHz
-----------	-------------------

Transmission frequencies up to 16 MHz in combination with large cable lengths place high technological demands on the cable. Due to the data transfer technology, the cable connected directly to the encoder must not be longer than 20 m. Greater cable lengths can be realized with a cable no longer than 6 m and an extension cable. As a rule, the entire transmission path must be designed for the respective clock frequency.

POSITION VALUES

The position value can be transmitted with or without additional data. It is not transmitted to the subsequent electronics until after the calculation time t_{cal} has passed. The calculation time is ascertained at the highest clock frequency permissible for the encoder, but limited at 8 MHz.

Only the required number of bits is transferred for the position value. The bit number can be read out from the encoder for automatic parameterization.

MEMORY AREAS

The encoder provides several memory areas for parameters. These can be read from by the subsequent electronics, and some can be written to by the encoder manufacturer, the OEM, or even the end user. The parameter data are stored in a permanent memory. This memory permits only a limited number of write access events and is not designed for cyclic data storage. Certain memory areas can be write-protected (this can only be reset by the encoder manufacturer).

Parameters are saved in various memory areas, e.g.:

- Encoder-specific informationen
- Informationen of the OEM (e. g. „electronic ID-label“ of the motor)
- Operating parameters (datum shift, instruction, etc.)
- Operating status (alarm or warning messages)

Monitoring and diagnostic functions of the EnDat interface make a detailed inspection of the encoder possible.

- Error messages
- Warnings
- Online diagnostics based on valuation numbers (EnDat 2.2)

Interface	EnDat 2.2 serial bidirectional
Data transfer	Position values, parameters and additional data
Data input	Differential line receiver according to EIA standard RS 485 for the signals CLOCK, $\overline{\text{CLOCK}}$, DATA and $\overline{\text{DATA}}$
Data output	Differential line driver according to EIA standard RS 485 for DATA and $\overline{\text{DATA}}$ signals
Position values	Ascending during traverse in direction of cable outlet
Power supply	3.6 V to 14 V

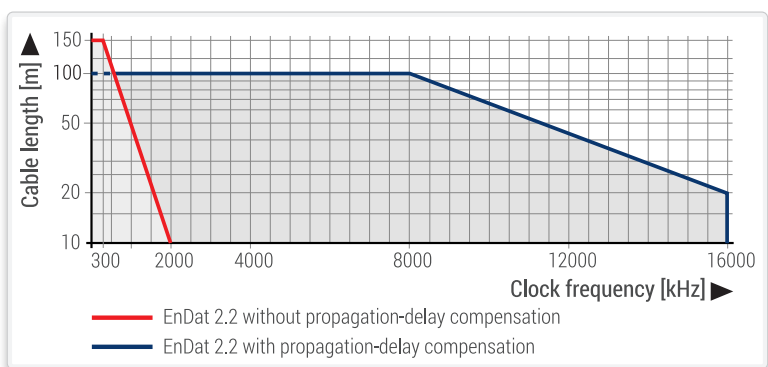

ADDITIONAL DATA

One or two items of additional data can be appended to the position value, depending on the type of transmission (selection via MRS code). The additional data supported by the respective encoder is saved in the encoder parameters.

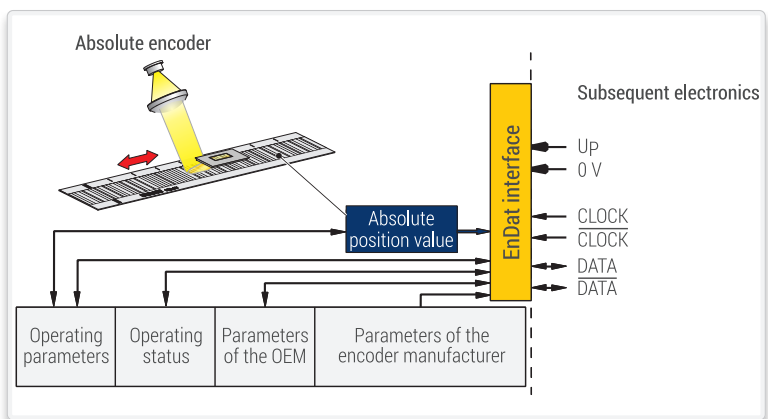

INPUT CIRCUITRY OF SUBSEQUENT ELECTRONICS

Dimensioning

IC1 = RS 485 differential line receiver
 $Z_0 = 120 \Omega$

*EnDat2.2 is a bidirectional interface of HEIDENHAIN.
 Detailed information you will find on: www.endat.de*

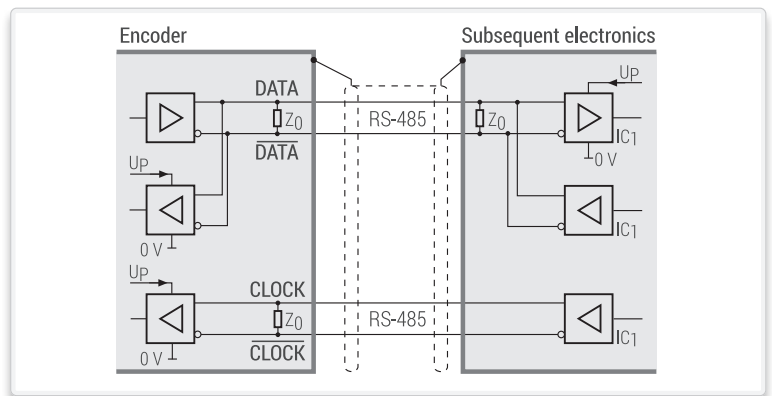

CUSTOMER-SPECIFIC SERIAL INTERFACES

BiSS C

RSF Elektronik encoders with the **Code B** after the model designation are suited for connection to BiSS C controls with **BiSS C unidirectional interface** (permissible clock frequencies ≤ 5 MHz or 10 MHz)

- Ordering designation: BiSS/Cu

Fanuc

RSF Elektronik encoders with the **Code F** after the model designation are suited for connection to Fanuc controls with **Fanuc Serial Interface**

- Ordering designation: Fanuc05 ai Interface

Mitsubishi

RSF Elektronik encoders with the **Code M** after the model designation are suited for connection to Mitsubishi controls with **Mitsubishi high speed interface**

- Ordering designation: Mit03-2
One-pair transmission
- Ordering designation: Mit03-4
Two-pair transmission

Panasonic

RSF Elektronik encoders with the **Code P** after the model designation are suited for connection to Panasonic controls with **Panasonic Serial Interface**

- Ordering designation: Pana02

Yaskawa

RSF Elektronik encoders with the **Code Y** after the model designation are suited for connection to Yaskawa controls with **Yaskawa Serial Interface**

- Ordering designation: YEC07

SHIELDING

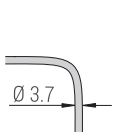

Shielded PUR-cable,
Drag chain qualified.

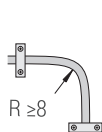

Bending radius
fixed mounting



Bending radius
continuous flexing

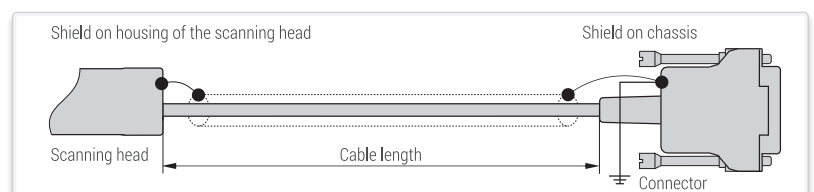

MC 15 TECHNICAL DATA

SCANNING HEAD

Model	AK MC 15	AK MC 15 B	AK MC 15 F	AK MC 15 M		AK MC 15 P	AK MC 15 Y
Interface	EnDat 2.2	BiSS C unidirectional	Fanuc serial interface α i Interface	Mitsubishi high speed interface		Panasonic serial interface	Yaskawa serial interface
Version	EnDat 2.2	BiSS/Cu	Fanuc05	Mit03-4	Mit03-2	Pana02	YEC07
Measuring step	0,1 μ m (100 nm) 0,05 μ m (50 nm)						
Calculation time t_{cal} Clock frequency	$\leq 5 \mu$ s ≤ 16 MHz	--	--	--	--	--	--
Traversing speed	≤ 600 m/min						
Interpolation error	Approx. $\pm 1 \mu$ m						
Electrical connection	Cable, 1 m or 3 m with M12-connector 8-pin or D-sub connector 15-pin						
Voltage supply	DC 3.6 V to 14 V (3.6 V at least required in the scanning head)						
Power consumption	At 3.6 V: ≤ 950 mW At 14 V: ≤ 1050 mW						
Current consumption typ.	At 5 V: 100 mA (without load)						
Vibration 55 Hz to 2000 Hz Shock 6 ms	≤ 500 m/s ² (EN 60 068-2-6) ≤ 1000 m/s ² (EN 60 068-2-27)						
Operating temperature Storage temperature	-10 °C to 70 °C -20 °C to 70 °C						
Mass	Scanning head: 12 g (without cable), connecting cable: 22 g/m, connector: M12-connector: 15 g; D-sub connector: 28 g						

GRADUATION CARRIER

Model	MB MC 15 MK	MC 15 MP	MC 15 GK	MC 15 BK
Graduation carrier	Steel tape scale with adhesive tape	Steel tape scale in aluminum carrier with clamping element	Glass scale with adhesive tape	Glass ceramic scale with adhesive tape
Coefficient of linear expansion	$\alpha \approx 10 \times 10^{-6}/K$	$\alpha \approx 10 \times 10^{-6}/K$	$\alpha \approx 8.5 \times 10^{-6}/K$	$\alpha \approx 0 \times 10^{-6}/K$
Accuracy grade (at 20 °C)	$\pm 15 \mu$ m/m	$\pm 15 \mu$ m/m	$\pm 5 \mu$ m/m	$\pm 5 \mu$ m/m
Measuring length ML	Up to 10 000 mm *	Up to 10 000 mm *	Up to 3140 mm	Up to 1920 mm
Mass	17 g/m	92 g/m + 2 g clamping	55 g/m	57 g/m

* longer lengths on request.

CONFORMITIES AND CERTIFICATIONS

RoHS	2011/65/EU, 2015/863/EU
EMV	2014/30/EU
Product-Certifications	UL, CSA, EN, IEC 61010-1

MC 15 MK

- Steel tape scale with absolute track and adhesive tape



Dimensions, mounting tolerances:

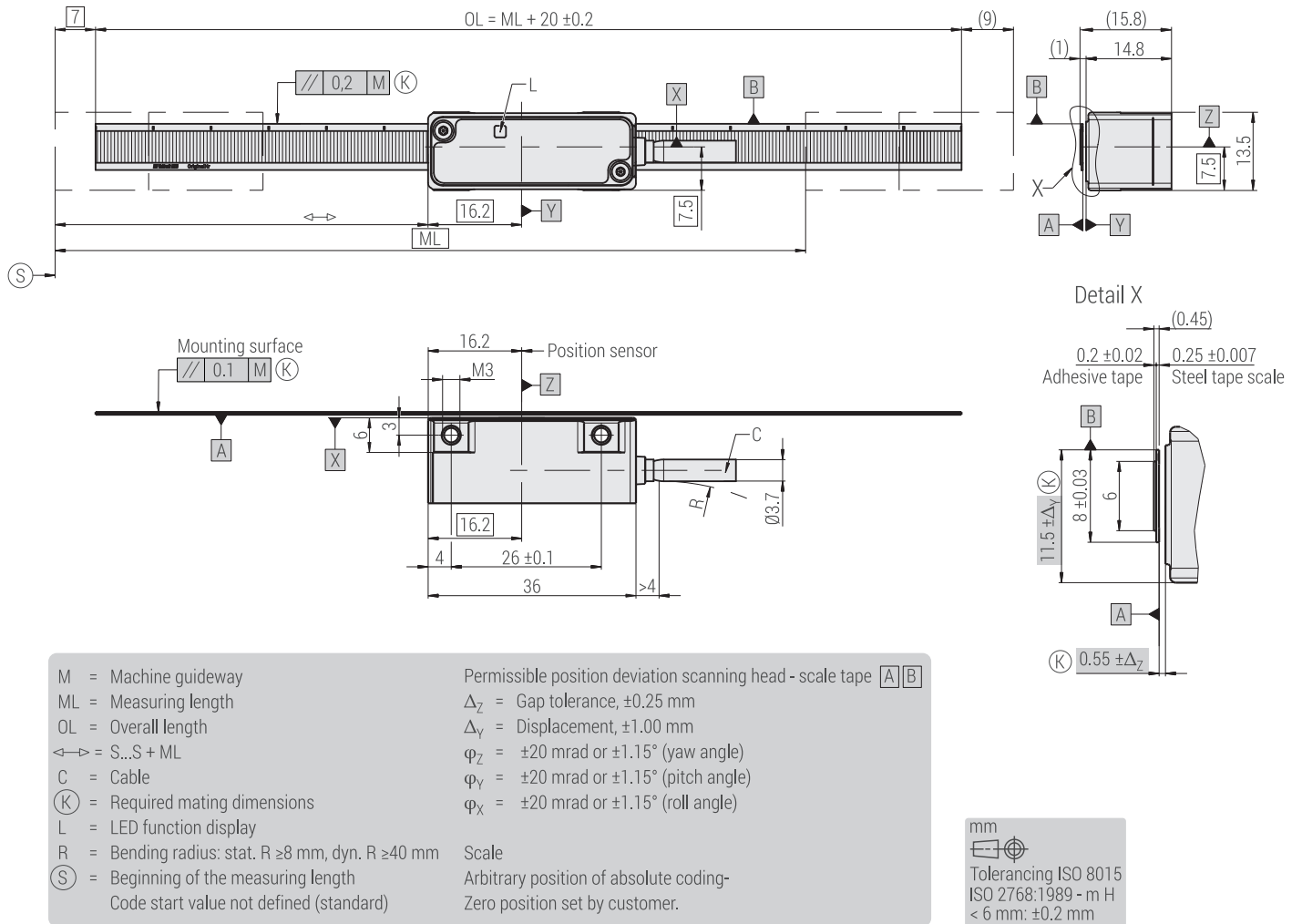

Tape mounting tool **TMT MS 15 MK** (optional)

For safe and precise mounting of the steel tape scale.

- Mount TMT MS 15 MK instead of the MC 15 scanning head.
- Thread steel tape scale (version MK) and move along the scale length.
- Remove TMT MS 15 MK, mount MC 15 scanning head.

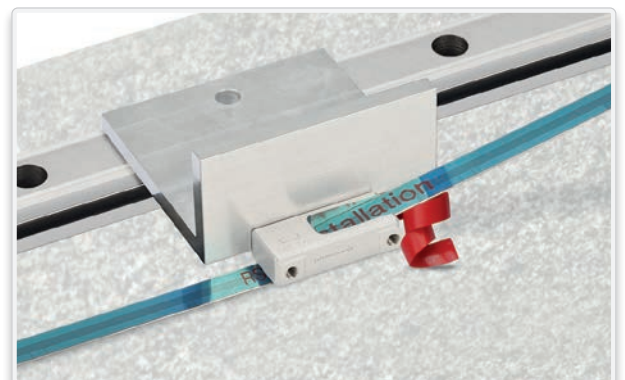

MC 15 MP

- Steel tape scale with absolute track in aluminum carrier with clamping element
- Clamping element bolted
- Carrier with adhesive tape



Dimensions, mounting tolerances:

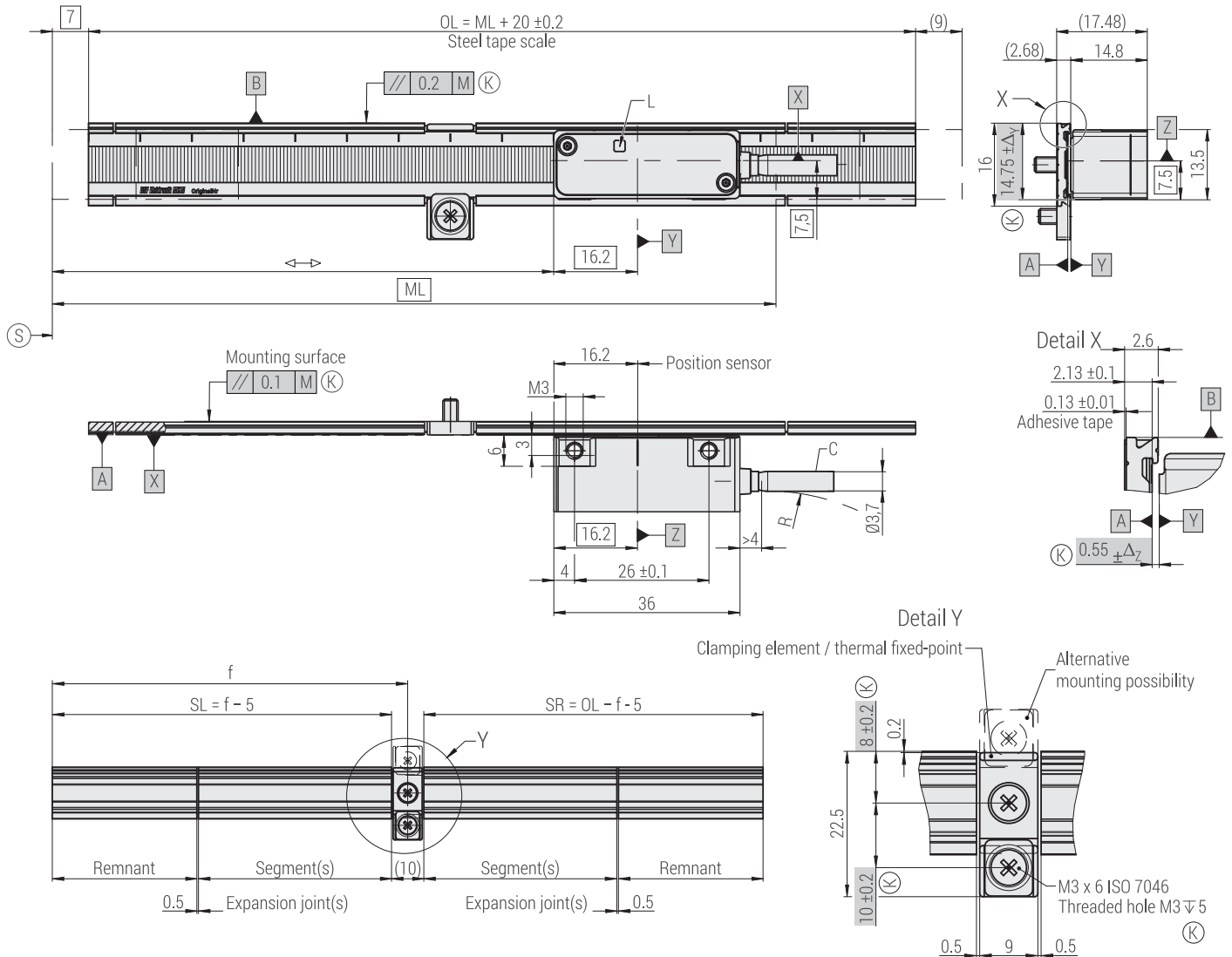

- M = Machine guideway
- ML = Measuring length
- OL = Overall length
- ↔ = S...S + ML
- f = Position of the clamping element
Standard: $f = OL/2$
Optional: $f = \begin{cases} 4.5 \\ \geq 25 \dots \leq OL - 25 \\ OL - 4.5 \end{cases}$

- C = Cable
- (K) = Required mating dimensions
- L = LED function display
- R = Bending radius: stat. $R \geq 8$ mm, dyn. $R \geq 40$ mm
- (S) = Beginning of the measuring length
Code start value not defined

Permissible position deviation of the scanning head - scale tape (A) (B)

- Δ_Z = Gap tolerance, $+0.25$ mm / -0.2 mm
- Δ_Y = Displacement, ± 0.5 mm
- φ_Z = ± 20 mrad or $\pm 1.15^\circ$ (yaw angle)
- φ_Y = ± 20 mrad or $\pm 1.15^\circ$ (pitch angle)
- φ_X = ± 20 mrad or $\pm 1.15^\circ$ (roll angle)

Scale
Arbitrary position of absolute coding-zero position set by customer.

mm
Tolerancing ISO 8015
ISO 2768:1989 - m H
< 6 mm: ± 0.2 mm

MC 15 BK, GK

- BK: Glass ceramic scale with absolute track and adhesive tape
- GK: Glass scale with absolute track and adhesive tape



Dimensions, mounting tolerances:

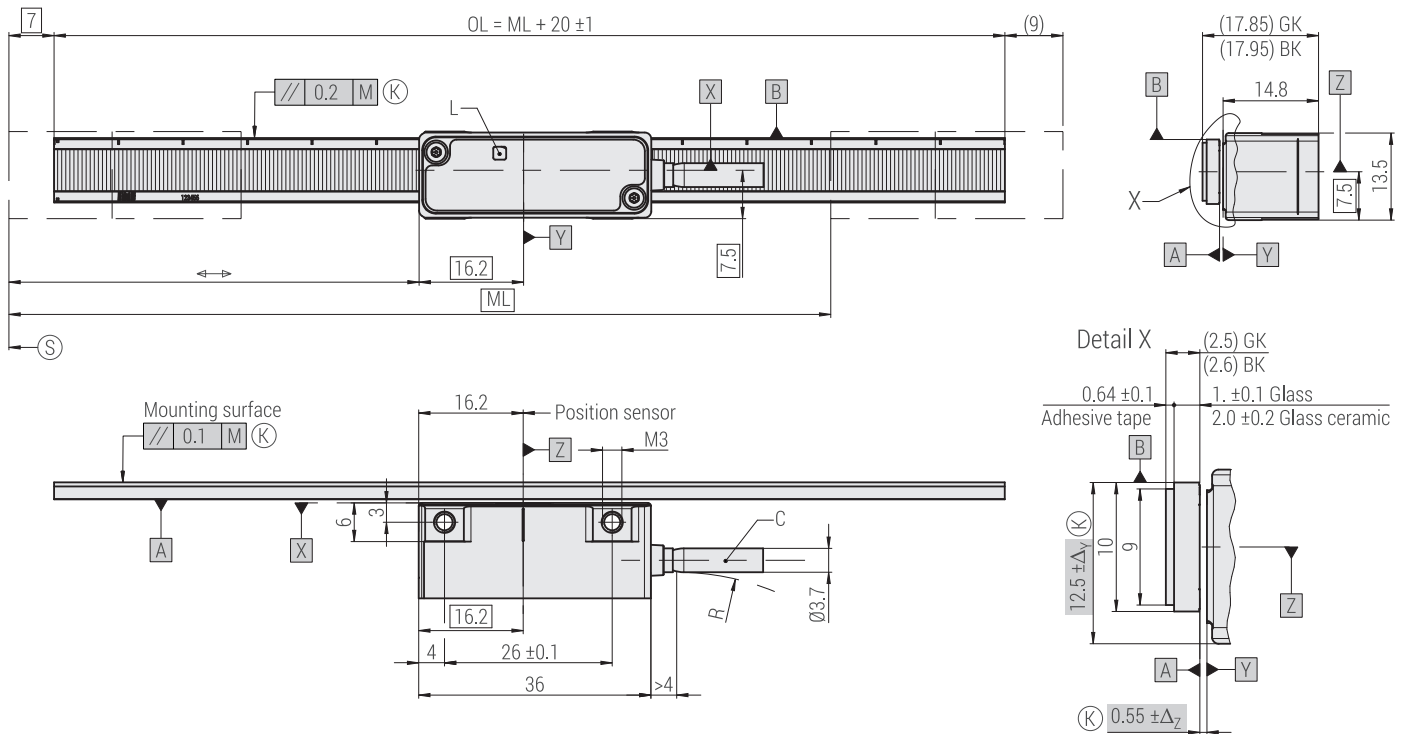

- | | |
|---|--|
| M = Machine guideway | Permissible position deviation scanning head - scale $\boxed{A} \boxed{B}$ |
| ML = Measuring length | Δ_z = Gap tolerance, ± 0.25 mm |
| OL = Overall length | Δ_y = Displacement, ± 1.00 mm |
| \longleftrightarrow = S...S + ML | φ_z = ± 20 mrad or $\pm 1.15^\circ$ (yaw angle) |
| C = Cable | φ_y = ± 20 mrad or $\pm 1.15^\circ$ (pitch angle) |
| \textcircled{K} = Required mating dimensions | φ_x = ± 20 mrad or $\pm 1.15^\circ$ (roll angle) |
| L = LED function display | Scale |
| R = Bending radius: stat. $R \geq 8$ mm, dyn. $R \geq 40$ mm | Arbitrary position of absolute coding - zero position set by customer. |
| \textcircled{S} = Beginning of the measuring length
Code start value not defined | |

mm

 Tolerancing ISO 8015
 ISO 2768:1989 - m H
 < 6 mm: ± 0.2 mm

ACCESSORY: EXTERNAL TESTING DEVICE PWT 101

The PWT 101 is a testing device for checking the function and adjustment of absolute RSF Elektronik encoders. Thanks to its compact dimensions and robust design, the PWT 101 is ideal for mobile use. A 4.3-inch touchscreen provides for display and operation.

For example, for encoders with EnDat interface you can not only display the position value but also export the online diagnosis, shift datums, and perform further inspection functions.

AVAILABLE FUNCTIONS

The performance range of the PWT 101 can be expanded by firmware update. Appropriate firmware files that can be imported to the PWT 101 through a memory card (not included in delivery) will be made available at www.heidenhain.de.



Feature content of the PWT 101	EnDat 2.2	BiSS/Cu	Fanuc05	Mitsubishi 03-4, 03-2	Panasonic02	YEC 07
Position display Display of the absolute position Display and resetting of error messages Display and resetting of warnings Display of transmission status	✓	✓	✓	✓	✓	✓
Diagnostics Display of online diagnostics Display of supply voltage and supply current	✓	✓	✓	✓	✓	✓
Additional functions (if supported by the encoder) Datum shift („electrical zeroing of position“)	✓	-	-	-	-	-
Memory contents Display of encoder information	✓	✓	✓	✓	✓	✓

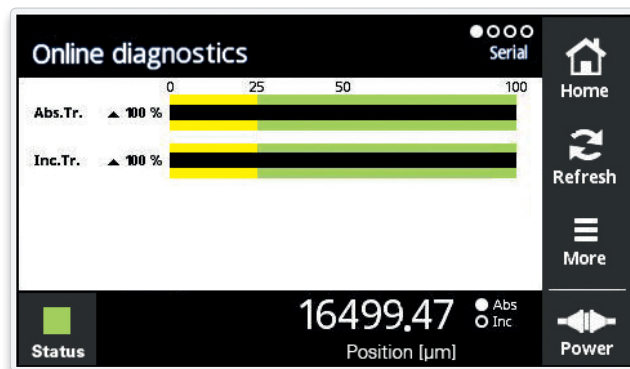

STATUS DISPLAY VIA LED FUNCTION

LED function at the scanning head	EnDat 2.2	BiSS/Cu	Fanuc05	Mitsubishi 03-4, 03-2	Panasonic02	YEC 07	Note
GREEN Very good	✓	✓	✓	✓	✓	✓	
YELLOW Warning	✓	✓	-	-	✓	-	Check mounting, clean encoder
RED Alarm	✓	✓	✓	✓	✓	✓	Check mounting, clean encoder

FURTHER PRODUCTS



MCR 15 | MCS 15

Absolute modular angle encoders with small dimensions

- Diverse serial interfaces
- Status display directly at the scanning head via LED function
- Easy mounting as a result of large mounting tolerances
- High insensitivity against contaminations
- Possible drum diameter (TTR): 50.00 mm to 350.23 mm (outside)
- Possible scanning diameter (MBR): 59.93 mm to 350.23 mm (outside)
- Possible scanning diameter (MCS): from 75 mm



MSR 15 | MSS 15

Incremental modular angle encoders with small dimensions

- Quality of the scanning signals is directly visible at the scanning head via a tricolored LED function
- Easy mounting as a result of large mounting tolerances
- High insensitivity against contaminations
- Possible drum diameter (TTR): 50.00 mm to 350.23 mm (outside)
- Possible scanning diameter (MBR): 59.93 mm to 350.23 mm (outside)
- Possible scanning diameter (MSS): from 75 mm



MSR 45

Modular angle encoders with steel tape scale - various versions

- Full-circle or segment version
- Grating period: 200 µm
- Accuracy of the grating (stretched): ±30 µm/m
- High permissible rotational speed resp. circumferential speed
- Integrated subdividing: up to times 100
- Possible diameter: Full-circle from Ø 146.99 mm
Segment from Ø 150 mm



MS 15

Exposed linear encoders with integrated mounting control

- Easy mounting; no test box or oscilloscope needed
- Quality of the scanning signals is directly visible at the scanning head via a tricolored LED function
- Two independent switch tracks for individual special functions
- Position of reference mark selectable by customer
- High insensitivity against contamination
- High permissible traversing speed
- Integrated subdividing: up to times 200
- Max. measuring length: Steel tape scale: 20 000 mm
Glass scale: 3140 mm

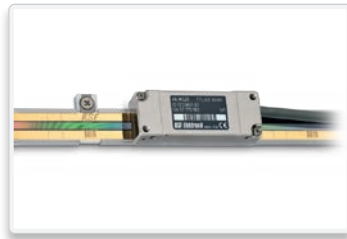

MS 25

Exposed scanning linear encoders with integrated mounting control

- Easy mounting; no test box or oscilloscope needed
- Quality of the scanning signals is directly visible at the scanning head via a tricolored LED function
- Two independent switch tracks for individual special functions
- Position of reference mark selectable by customer
- High insensitivity against contamination
- High permissible traversing speed
- Integrated subdividing: up to times 200
- Max. measuring length: Glass scale: 3140 mm
Steel tape scale: 20 000 mm



MS 45

Exposed linear encoders with integrated mounting control

- Easy mounting; no test box or oscilloscope needed
- Quality of the scanning signals is directly visible at the scanning head via a tricolored LED function
- Flat dimensions
- Easy mounting due to large mounting tolerances
- High insensitivity against contamination
- High permissible traversing speed
- Integrated subdividing: up to times 100
- Max. measuring length: Steel tape scale: 30 000 mm

DISTRIBUTION CONTACTS

AUSTRIA <i>Corporate Head Quarters</i>	RSF Elektronik Ges.m.b.H.	A-5121 Tarsdorf 93	☎ +43 62 78 81 92-0 FAX +43 62 78 81 92-79	e-mail: info@rsf.at internet: www.rsf.at
BELGIUM	HEIDENHAIN NV/SA	Pamelse Klei 47 1760 Roosdaal	☎ +32 (54) 34 3158 FAX +32 (54) 34 3173	e-mail: sales@heidenhain.be internet: www.heidenhain.be
FRANCE	HEIDENHAIN FRANCE sarl	2 Avenue de la Christallerie 92310 Sèvres	☎ +33 1 41 14 30 00 FAX +33 1 41 14 30 30	e-mail: info@heidenhain.fr internet: www.heidenhain.fr
GREAT BRITAIN	HEIDENHAIN (GB) Ltd.	200 London Road Burgess Hill West Sussex RH15 9RD	☎ +44 1444 247711 FAX +44 1444 870024	e-mail: sales@heidenhain.co.uk internet: www.heidenhain.co.uk
ITALY	HEIDENHAIN ITALIANA S.r.l.	Via Asiago, 14 20128 Milan	☎ +39 02 27075-1 FAX +39 02 27075-210	e-mail: info@heidenhain.it internet: www.heidenhain.it
NETHERLANDS	HEIDENHAIN NEDERLAND B.V.	Copernicuslaan 34 6716 BM EDE	☎ +31 318-581800 FAX +31 318-581870	e-mail: verkoop@heidenhain.nl internet: www.heidenhain.nl
SPAIN	FARRESA ELECTRONICA S.A	Les Corts 36-38 08028 Barcelona	☎ +34 93 4 092 491 FAX +34 93 3 395 117	e-mail: farresa@farresa.es internet: www.farresa.es
SWEDEN	HEIDENHAIN Scandinavia AB	Storsåtragränd 5 SE-12739 Skärholmen	☎ +46 8 531 933 50 FAX +46 8 531 933 77	e-mail: sales@heidenhain.se internet: www.heidenhain.se
SWITZERLAND	HEIDENHAIN (SCHWEIZ) AG	Vieristrasse 14 8603 Schwerzenbach	☎ +41 44 806 27 27 FAX +41 44 806 27 28	e-mail: verkauf@heidenhain.ch internet: www.heidenhain.ch
CHINA	DR. JOHANNES HEIDENHAIN (CHINA) Co., Ltd	Tian Wei San Jie, Area A, Beijing Tianzhu Airport Industrial Zone Shunyi District, Beijing 101312	☎ +86 10 80 42-0000	e-mail: sales@heidenhain.com.cn internet: www.heidenhain.com.cn
ISRAEL	MEDITAL Hi-Tech	36 Shacham St., P.O.Box 7772 4951729 Petach Tikva	☎ +972 0 3 923 33 23 FAX +972 0 3 923 16 66	e-mail: avi@medital.co.il internet: www.medital.co.il
JAPAN	HEIDENHAIN K.K.	Hulic Kojimachi Bldg., 9F 3-2 Kojimachi, Chiyoda-ku Tokyo, 102-0083	☎ +81 3 3234 7781 FAX +81 3 3262 2539	e-mail: sales@heidenhain.co.jp internet: www.heidenhain.co.jp
KOREA	HEIDENHAIN LTD.	75, Jeonpa-ro 24beon-gil, Manan-gu, Anyang-si 14087 Gyeonggi-do	☎ +82 31 380 5200 FAX +82 31 380 5250	e-mail: info@heidenhain.co.kr internet: www.rsf.co.kr
SINGAPORE	HEIDENHAIN PACIFIC PTE LTD.	51, Ubi Crescent 408593 Singapore	☎ +65 67 49 32 38 FAX +65 67 49 39 22	e-mail: info@heidenhain.com.sg internet: www.heidenhain.com.sg
TAIWAN	HEIDENHAIN CO., LTD.	No. 29, 33rd Road; Taichung Industrial Park Taichung 40768	☎ +886 4 2358 89 77 FAX +886 4 2358 89 78	e-mail: info@heidenhain.tw internet: www.heidenhain.com.tw
USA	HEIDENHAIN CORPORATION	333 East State Parkway Schaumburg, IL 60173-5337	☎ +1 847 490 11 91	e-mail: info@heidenhain.com internet: www.heidenhain.com

Date 05/2023 ■ Art.No. 1210495-04 ■ Doc.No. D1210495-05-C-01 ■ Technical adjustments in reserve!



RSF Elektronik

Ges.m.b.H.

Linear and Angle Encoders
Precision Graduations

Certified acc. to
ISO 9001
ISO 14001

