

SL, SR = segment length / Segmentlänge  
 ≥ 20 ... ≤ 1000 = 1x remnant / Reststück (≥ 20 ... ≤ 1000)  
 >1000 ... ≤ 1500 = 1x 499,5 + 1x remnant / Reststück (>500 ... ≤ 1000)  
 >1500 ... ≤ 2000 = 1x 999,5 + 1x remnant / Reststück (>500 ... ≤ 1000)  
 >2000 ... ≤ 2500 = 1x 499,5 + 1x 999,5 + 1x remnant / Reststück (>500 ... ≤ 1000)  
 >2500 ... ≤ 3000 = 2x 999,5 + 1x remnant / Reststück (>500 ... ≤ 1000)  
 >3000 ... ≤ 3500 = 1x 499,5 + 2x 999,5 + 1x remnant / Reststück (>500 ... ≤ 1000)  
 etc.

M = machine guideway / Maschinenführung  
 ML = measuring length / Messlänge  
 OL = overall length / Gesamtlänge  
 ← → = S...S+ML  
 → + = direction of motion of the scanning unit for ascending position values  
 Bewegungsrichtung des Abtastkopfes für steigende Positionswerte  
 Ⓢ = code start value not defined (standard) / Codestartwert nicht definiert (Standard)  
 code start value on customer request ≥ 16 mm (optional) / Codestartwert nach Kundenwunsch ≥ 16 mm (optional)

C = cable / Anschlusskabel  
 (K) = required mating dimensions / kundenseitige Anschlussmaße  
 L = LED function display / LED Funktionsanzeige  
 R = bending radius / Biegeradius: stat. R ≥ 8mm, dyn. R ≥ 40mm  
 f = OL/2 (standard)  
 any position of the clamping element (optional)  
 beliebige Position des Klemmelements (optional)  
 n = 1,2,3, ... (number of segments / Anzahl der Segmente)

Permissible position deviation scanning head - scale tape A B  
 Zulässige Lageabweichungen Abtastkopf - Maßband A B  
 Δ<sub>z</sub> = +0.25mm / -0.2mm (airgap / Abstand)  
 Δ<sub>y</sub> = ±0.5mm (lateral / Verschiebung)  
 φ<sub>z</sub> = ±20mrad or / oder ±1.15° (yaw angle / Gierwinkel)  
 φ<sub>y</sub> = ±20mrad or / oder ±1.15° (pitch angle / Nickwinkel)  
 φ<sub>x</sub> = ±20mrad or / oder ±1.15° (roll angle / Rollwinkel)

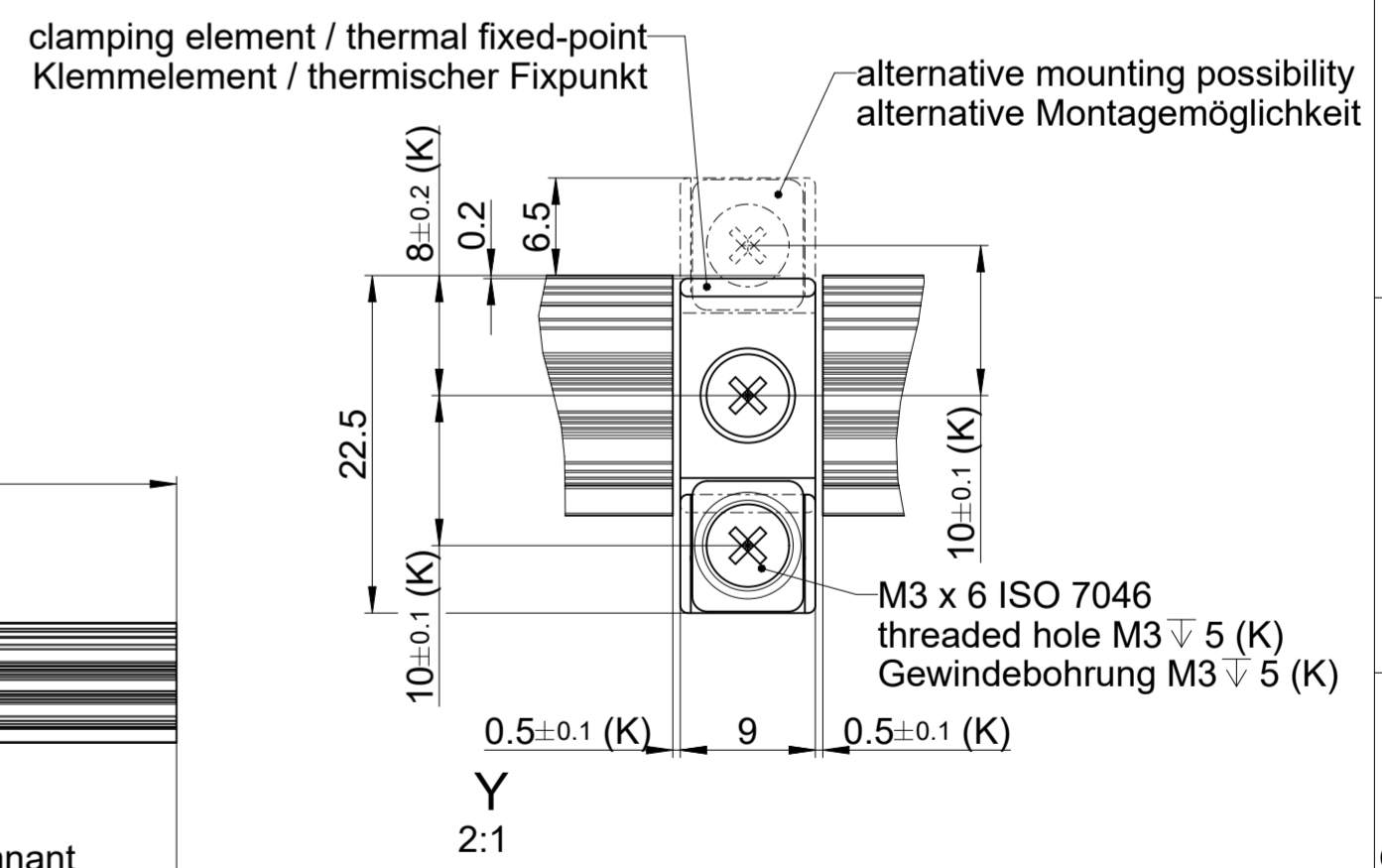
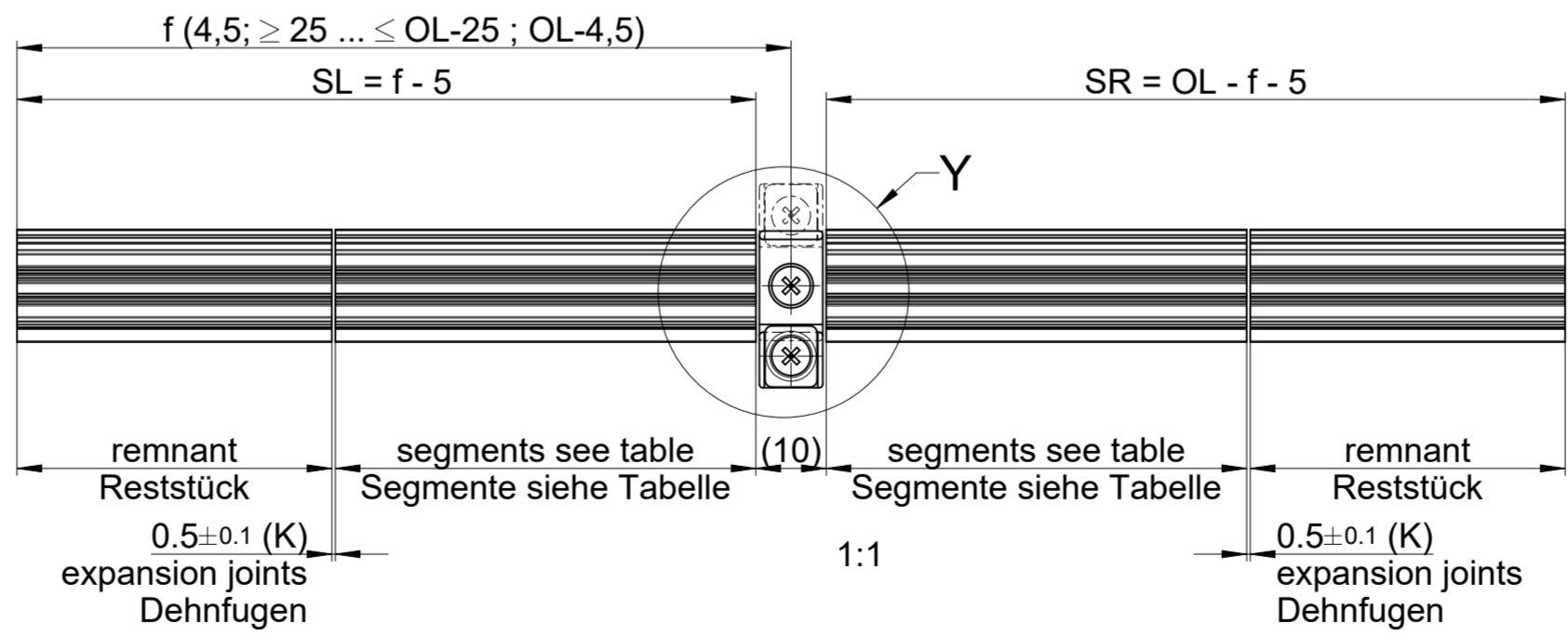

Original drawing		Scale		Format		MC15 MP		ID number:	
2:1		A2		Anschlussmaße / Mating Dimensions		MC15 MP		C157360-30	
Dimensions in mm								Change No. Serie	
								Phase: C157360-30	
								Tolerances as per ISO 8015	
								General Tolerances ISO 2768:1989-mH ≤ 6±0.2	
The reproduction, distribution and utilization of this document as well as the communication of its contents to others without express authorization is prohibited. Offenders will be held liable for the payment of damages. All rights reserved in the event of the grant of a patent, utility model or design. (ISO 16016)									
Released		Version		Revision		Sheet		Page	
21.06.2024		D1197344-06-B-01		1		1		1	
www.rsfelektronik.at		Document number							