



HEIDENHAIN



Product Overview

Rotary Encoders for Potentially Explosive Atmospheres (ATEX)

Rotary encoders for use in potentially explosive atmospheres

Introduction

There are many types of applications in industry where exposure to potentially explosive atmospheres is virtually unavoidable, for example on paint spray lines, printing machines, or silage systems.

The condition of equipment and facilities operated in potentially explosive atmospheres is defined by **ATEX Directive 2014/34/EU** (ATEX derives its name from the French "atmosphères explosibles," which means explosive atmospheres).

This directive has been in effect since February 26, 2014, and has replaced all other existing regulations that cover the same subjects within the entire European Union (EU). In the field of explosion protection, national regulations must not contain any diverging requirements and/or any requirements beyond the scope of this directive. Products that are placed on the market or put into service after February 26, 2014, must meet the requirements of the directive.

Standard

CENELEC (European Committee for Electrotechnical Standardization) prepared the EU standard EN 60079 for explosion protection on the basis of the EU directive.

Usability (classification into zones and categories)

In potentially explosive atmospheres, the operating conditions must be considered carefully. The installer/operator must therefore assess the explosion risk of production facilities and divide them into zones that reflect the degree of danger based on:

- the probability and duration of the occurrence of dangerous potentially explosive atmospheres,
- the probability of the presence, activation, and effectiveness of sources of ignition, as well as
- the scope of the expected effects of explosions.

Operating equipment for potentially explosive atmospheres is classified into **three categories** (for Equipment Group II for electrical equipment except mines liable to be endangered by firedamp), depending on its design:

- Category 1 ensures a very high level of safety
- Category 2 ensures a high level of safety
- Category 3 ensures a normal level of safety

Classification into zones

The composition of the atmosphere is decisive for the classification into zones:

- Potentially explosive atmosphere consisting of a mixture of air and gases, vapors, or mists
 - Zone 0: Continuously, for long periods, frequently, majority of the time
 - Zone 1: Occasionally in normal operation
 - Zone 2: Rare, for a short period
- Potentially explosive atmosphere that consists of a mixture of air and dust
 - Zone 20: Continuously, for long periods, frequently, majority of the time
 - Zone 21: Occasionally in normal operation
 - Zone 22: Rare, for a short period

Designation

All explosion-proof electrical devices are marked using a uniform code.

Gas atmosphere

- II = Equipment group (II = for above-ground applications)
- 2 = Category
- G = Gas
- Ex = Explosion protection
- db = Type of ignition protection (db = flameproof enclosure)
- II = Explosion group gas
- C = Subgroup: C (maximum permitted gap < 0.5 mm)
- T120 °C = Maximum surface temperature
- Gb = High protection level against gas

Dust atmosphere

- II = Equipment group (II = for above-ground applications)
- 2 = Category
- D = Dust
- Ex = Explosion protection
- tb = Ignition protection (tb = protection by housing)
- III = Procedure for determining dust proofness (explosion group dust)
- C = Conductive dust
- T120 °C = Maximum surface temperature
- Db = High protection level against dust



Equipment Group II (other potentially explosive atmospheres)

Category	1: Very high level of safety		2: High level of safety		3: Normal level of safety	
Risk level	Continuous, long-term and frequent risk		Occasional risk		Unlikely and short-term risk	
Adequate safety	By means of two protective measures/with two faults		In case of frequently occurring equipment faults/with one fault		In case of fault-free operation	
Use in	Zone 0	Zone 20	Zone 1	Zone 21	Zone 2	Zone 22
Atmosphere	G (gas)	D (dust)	G	D	G	D

Comparison of equipment groups and categories

HEIDENHAIN produces special rotary encoders for potentially explosive atmospheres. They comply with **Equipment Group II**, meet the requirements of **category 2**, and can be used for **zones 1 and 21** as well as **zones 2 and 22** (devices for zone 0 are available on request).

Type of ignition protection

The rotary encoders for potentially explosive atmospheres fulfill the requirements of the following types of ignition protection: flameproof enclosure (db) or protection by housing (tb). A **flameproof enclosure db** is designed in such a way that the parts that can ignite a potentially explosive atmosphere are located within a housing that can withstand the pressure of an explosion of the potentially explosive atmosphere inside the housing, and that prevents a transfer of the explosion to the potentially explosive atmosphere surrounding the housing. The maximum permitted gap is less than 0.5 mm (corresponds to explosion group IIC).

The **protection by housing tb** type of ignition protection means that the ingress of dust is prevented (IP66 protection). Also, dust deposition forming conductive dust layers with a thickness of up to 5 mm is considered for the maximum surface temperature.

Maximum surface temperature

The temperature applies for a **maximum ambient temperature of +60 °C**. Thermal switches in the rotary encoder flange ensure that the maximum surface temperature is not exceeded. At a temperature of 100 °C (± 5 K) at a thermal switch, they trigger the fault detection signal U_{AS} ($U_{AS} = \text{low}$), thereby indicating that the maximum permissible operating temperature is being exceeded. At a temperature of 110 °C (± 5 K) at a thermal switch, the power supply is switched off.

Repair

In case of a defect, repair of the rotary encoders is subject to stringently specified conditions. The rotary encoders must therefore be returned to HEIDENHAIN in Traunreut, because this ensures that the stringent requirements will be fulfilled.

Overview

This Product Overview contains all specifications for selecting HEIDENHAIN rotary encoders for potentially explosive atmospheres. For further specifications, please refer to the respective standard versions described in the *Rotary Encoders* brochure.

Mounting criteria

• Power consumption

In order to limit the maximum current in the event of a fault, the power consumption of the rotary encoder must be limited to a maximum of 10 W in the subsequent electronics. Comply with the additional measures for electrical safety in the *Interfaces* brochure.

• Voltage supply

Comply with the *General electrical information* in the *Interfaces* brochure.

• Connecting cable

The connecting cable that is permanently mounted on the rotary encoder must have a **rigid configuration** within the potentially explosive atmosphere. The rotary encoders for potentially explosive

atmospheres are supplied by HEIDENHAIN with a 10 m connecting cable as a standard feature. The connection must be located **outside of the potentially explosive atmosphere** or in an ATEX terminal box.

• Radial shaft seal ring

In order to protect the radial shaft seal ring from UV radiation, a rotor coupling must be used when mounting encoders with a solid shaft, or a clamping ring must be used for encoders with a hollow shaft.

• Protection against contact (EN 60529)

After encoder installation, all rotating parts must be protected against accidental contact during operation.

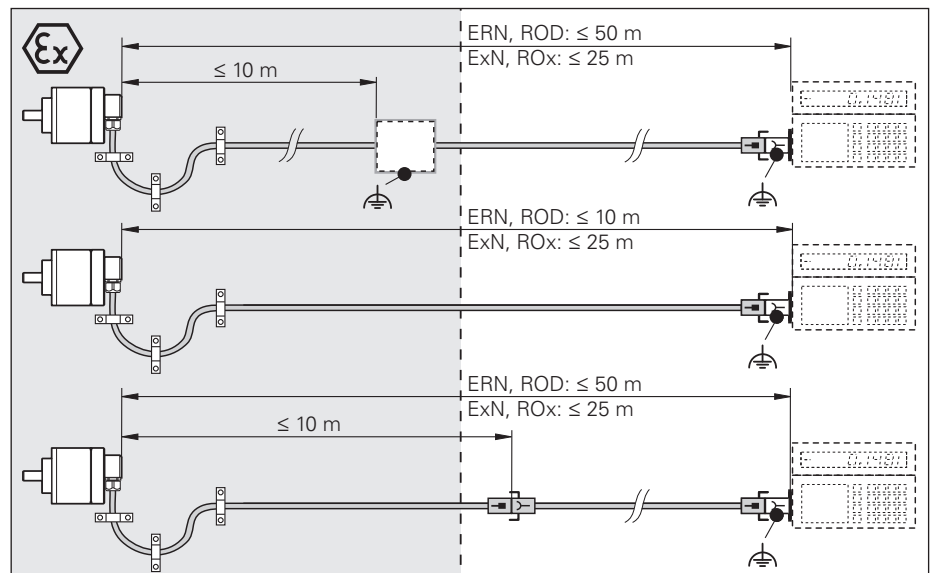

Input circuitry of subsequent electronics

The input circuits of the subsequent electronics for EnDat and SSI are described in detail in the *Interfaces of HEIDENHAIN Encoders* brochure.

Differences in SSI interfaces:

- No programming inputs
- t_2 start with positive edge (12 to 30 μs).

The ATEX encoders also provide a fault detection signal in TTL or HTL levels over a separate line when the integrated thermal switches measure a temperature greater than 100 °C (see *Maximum surface temperature*).

Dimensioning

IC_1 = Recommended differential line receiver
 DS 26 C 32 AT
 Only for a $> 0.1 \mu\text{s}$:
 AM 26 LS 32
 MC 3486
 SN 75 ALS 193

$R_1 = 4.7 \text{ k}\Omega$

$R_2 = 1.8 \text{ k}\Omega$

$Z_0 = 120 \Omega$

$C_1 = 220 \text{ pF}$ (serves to improve noise immunity)

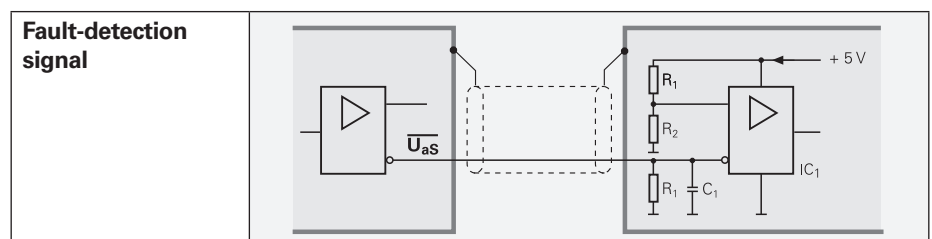

ECN/EQN/ERN 400 series

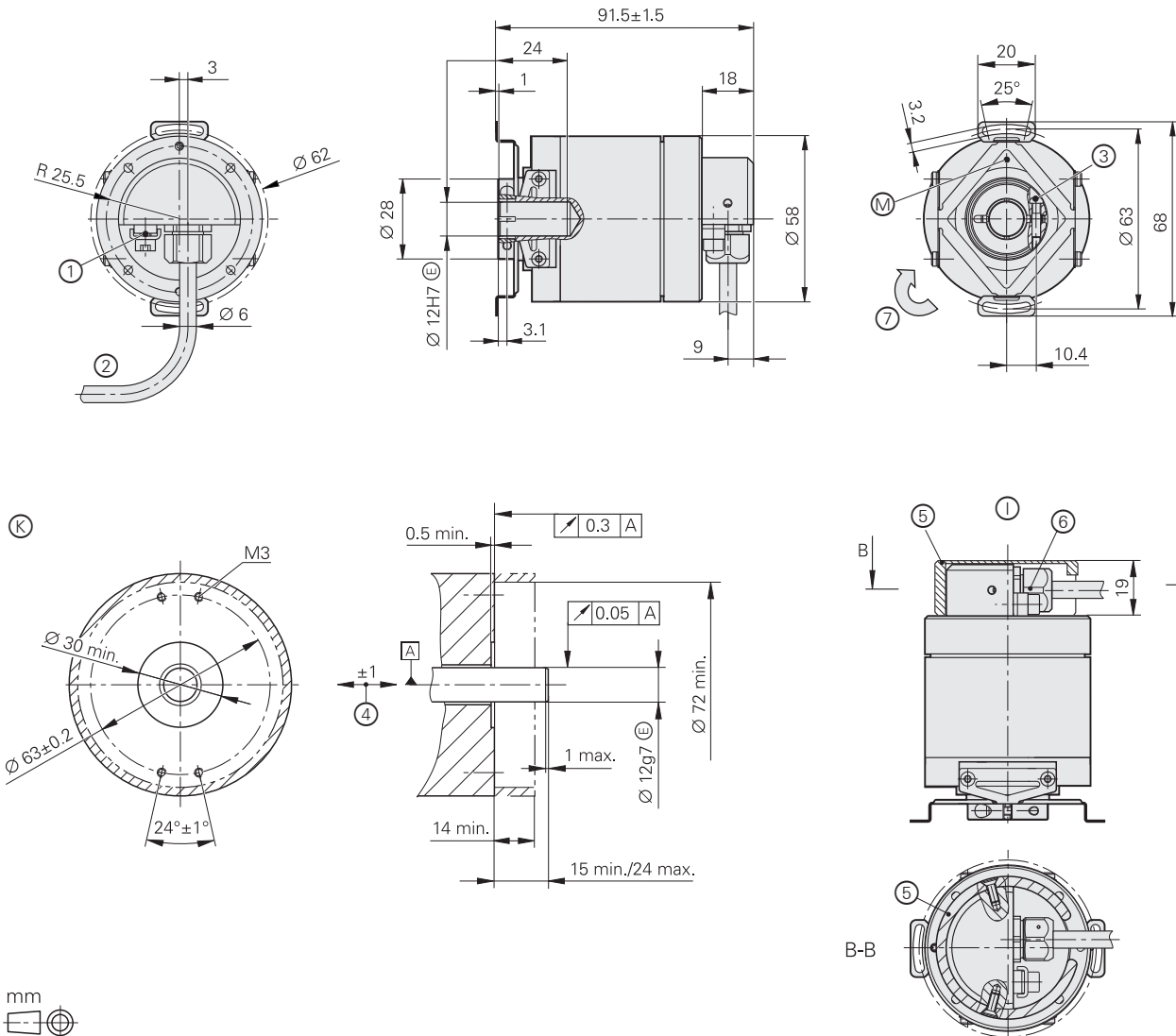

- Absolute and incremental rotary encoders
- Stator coupling for plane surface
- Blind hollow shaft
- For use in potentially explosive atmospheres



mm

 Tolerancing ISO 8015
 ISO 2768 - m H
 < 6 mm: ±0.2 mm

- ▣ = Bearing of mating shaft
- ⊗ = Required mating dimensions
- Ⓜ = Measuring point for operating temperature on encoder flange
- 1 = Connecting part for equipotential grounding and bonding according to DIN EN 60079-0
- 2 = Provide cable strain relief
- 3 = X8 clamping screw with hexalobular socket, tightening torque: 1.1 Nm ±0.1 Nm
- 4 = Compensation of mounting tolerances and thermal expansion; not dynamic motion
- 5 = Protective cap
- 6 = Cable bushing for cable Ø 6
- 7 = Direction of rotation for ascending position values
- ⓪ = Additional means of protection for cable bushing that may be exposed to external load when the encoder is integrated vertically (Directive 2014/34/EU)

	Incremental		
	ERN 420	ERN 430	ERN 480
Interface	 TTL	 HTL	 1 V _{PP} ¹⁾
Line counts*	1000 1024 1250 2000 2048	2500 3600 4096 5000	
Reference mark	One		
Cutoff frequency -3 dB	-		≥ 180 kHz
Scanning frequency	≤ 300 kHz		-
Edge separation <i>a</i>	≥ 0.39 μs		-
System accuracy	1/20 of grating period		
Supply voltage	DC 5 V ±0.5 V	DC 10 V to 30 V	DC 5 V ±0.5 V
Current consumption without load	≤ 120 mA	≤ 150 mA	≤ 120 mA
Electrical connection	Cable (10 m) with 12-pin M23 coupling (male)		
Shaft	Blind hollow shaft, D = 12 mm		
Mech. permiss. speed <i>n</i>	≤ 5000 rpm		
Starting torque (typical)	0.015 Nm (at 20 °C)		
Moment of inertia of rotor	≤ 5.1 · 10 ⁻⁶ kgm ²		
Permissible axial motion of measured shaft	±1 mm		
Vibration 55 Hz to 2000 Hz	≤ 100 m/s ² (EN 60068-2-6)		
Shock 6 ms	≤ 1500 m/s ² (EN 60068-2-27)		
Operating temperature	-20 °C to +80 °C		
Ambient temperature	-20 °C (stationary cable) to +60 °C		
Surface temperature	≤ 120 °C		
Protection EN 60529	IP66		
Explosion protection as per	DIN EN 60079-0; DIN EN 60079-1; DIN EN 60079-31		
Equipment group	II		
Category	2		
Explosive atmosphere	G (gas) and D (dust)		
Type of ignition protection	db and tb		
Explosion group and subgroup	IIC (maximum permitted gap < 0.5 mm) and IIIC		
Mass	≈ 0.7 kg		
ID number	384714-xx	384715-xx	384717-xx

* Please select when ordering

¹⁾ Restricted tolerances: Signal amplitude: 0.8 V_{PP} to 1.2 V_{PP}

	Absolute	
	Singleturn	
	ECN 413	
Interface*	EnDat 2.2	SSI
Ordering designation	EnDat01	SSI01r1
Positions per revolution	8192 (13 bits)	
Revolutions	–	
Code	Pure binary	Gray
Electrically permissible speed Deviations ¹⁾	512 lines: ≤ 5000/12 000 rpm ±1 LSB/±100 LSB 2048 lines: ≤ 1500/12 000 rpm ±1 LSB/±50 LSB	≤ 12 000 rpm ±12 LSB
Calculation time t_{cal} Clock frequency	≤ 9 μs ≤ 2 MHz	≤ 5 μs –
Incremental signals	$\sim 1 V_{PP}$ ¹⁾	
Line counts*	512 2048	512
Cutoff frequency –3 dB	512 lines: ≥ 130 kHz; 2048 lines: ≥ 400 kHz	
System accuracy	512 lines: ±60"; 2048 lines: ±20"	
Supply voltage	DC 5 V ±0.25 V	
Power consumption (max.)	≤ 625 mW	≤ 600 mW
Current consumption (typical; without load)	85 mA	70 mA
Electrical connection	Cable (10 m) with 17-pin M23 coupling (male)	
Shaft	Blind hollow shaft, D = 12 mm	
Mech. permiss. speed n	≤ 5000 rpm	
Starting torque (typical)	0.015 Nm (at 20 °C)	
Moment of inertia of rotor	≤ $5.1 \cdot 10^{-6}$ kgm ²	
Permissible axial motion of measured shaft	±1 mm	
Vibration 55 Hz to 2000 Hz Shock 6 ms	≤ 100 m/s ² (EN 60068-2-6) ≤ 1500 m/s ² (EN 60068-2-27)	
Operating temperature	–20 °C to +80 °C	
Ambient temperature	–20 °C (stationary cable) to +60 °C	
Surface temperature	≤ 120 °C	
Protection EN 60529	IP66	
Explosion protection as per	DIN EN 60079-0; DIN EN 60079-1; DIN EN 60079-31	
Equipment group Category Explosive atmosphere Type of ignition protection Explosion group and subgroup	II 2 G (gas) and D (dust) db and tb IIC (maximum permitted gap < 0.5 mm) and IIIC	
Mass	≈ 0.7 kg	
ID number	815145-xx	815144-xx

* Please select when ordering

¹⁾ Restricted tolerances: Signal amplitude: 0.8 V_{PP} to 1.2 V_{PP}

Multiturn EQN 425		
EnDat 2.2		SSI
EnDat01		SSI07r1
4096		
Pure binary		Gray
<i>512 lines:</i> ≤ 5000/10 000 rpm ±1 LSB/±100 LSB <i>2048 lines:</i> ≤ 1500/10 000 rpm ±1 LSB/±50 LSB		≤ 12 000 rpm ±12 LSB
≤ 9 µs ≤ 2 MHz		≤ 5 µs –
512 2048		512
≤ 700 mW		≤ 675 mW
105 mA		88 mA
815150-xx		815149-xx

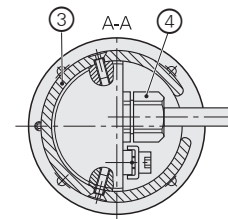
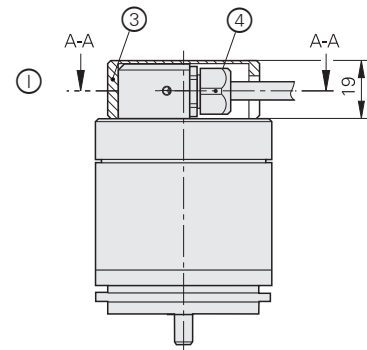
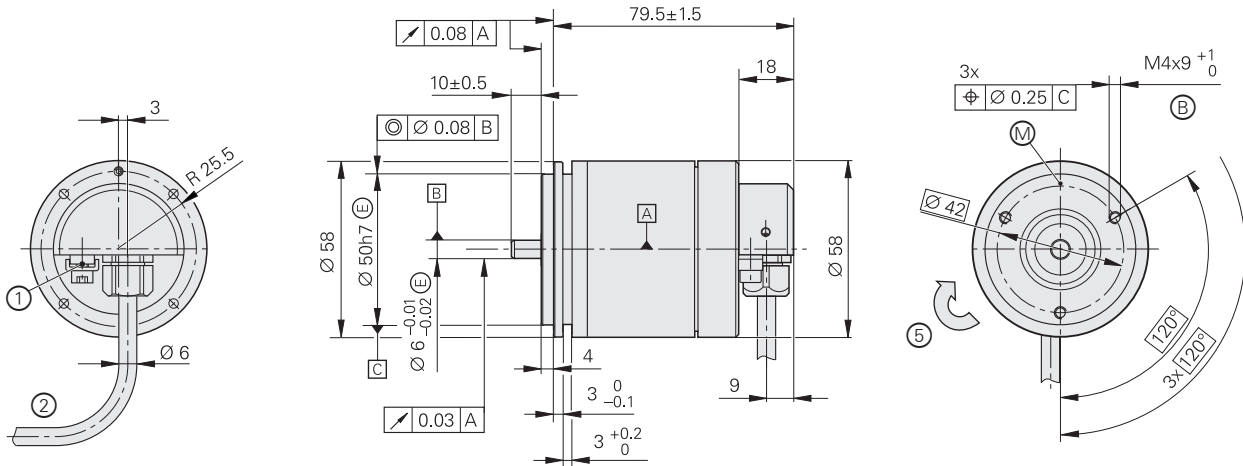

ROC/ROQ/ROD 400 series

- Absolute and incremental rotary encoders
- Synchro flange
- Solid shaft for separate shaft coupling
- For use in potentially explosive atmospheres



mm
 Tolerancing ISO 8015
 ISO 2768 - m H
 < 6 mm: ±0.2 mm

- ▣ = Encoder bearing
- ⊕ = Threaded mounting hole
- Ⓜ = Measuring point for operating temperature on encoder flange
- ① = Connecting part for equipotential grounding and bonding according to DIN EN 60079-0
- ② = Provide cable strain relief
- ③ = Protective cap
- ④ = Cable bushing for cable
- ⑤ = Direction of rotation for ascending position values
- ⓪ = Additional means of protection for cable bushing that may be exposed to external load when the encoder is integrated vertically (Directive 2014/34/EU)

	Incremental		
	ROD 426	ROD 436	ROD 486
Interface	 TTL	 HTL	 1 V _{PP} ¹⁾
Line counts*	1000 1024 1250 1500 1800	2000 2048 2500 3600 4096	5000
Reference mark	One		
Cutoff frequency –3 dB Scanning frequency Edge separation <i>a</i>	– ≤ 300 kHz ≥ 0.39 μs		≥ 180 kHz – –
System accuracy	1/20 of grating period		
Supply voltage Current consumption without load	DC 5 V ±0.5 V ≤ 120 mA	DC 10 V to 30 V ≤ 150 mA	DC 5 V ±0.5 V ≤ 120 mA
Electrical connection	Cable (10 m) with 12-pin M23 coupling (male)		
Shaft	Solid shaft D = 6 mm		
Mechanically permissible speed <i>n</i>	≤ 10000 rpm		
Starting torque (typical)	0.015 Nm (at 20 °C)		
Moment of inertia of rotor	≤ 4.4 · 10 ⁻⁶ kgm ²		
Shaft load ²⁾	<i>Axial</i> : ≤ 40 N; <i>radial</i> : ≤ 60 N at shaft end		
Vibration 55 Hz to 2000 Hz Shock 6 ms	≤ 300 m/s ² (EN 60068-2-6) ≤ 1500 m/s ² (EN 60068-2-27)		
Operating temperature	–20 °C to +80 °C		
Ambient temperature	–20 °C (stationary cable) to +60 °C		
Surface temperature	≤ 120 °C		
Protection EN 60529	IP66		
Explosion protection as per	DIN EN 60079-0; DIN EN 60079-1; DIN EN 60079-31		
Equipment group Category Explosive atmosphere Type of ignition protection Explosion group and subgroup	II 2 G (gas) and D (dust) db and tb IIC (maximum permitted gap < 0.5 mm) and IIIC		
Mass	≈ 0.7 kg		
ID number	377237-xx	377238-xx	377240-xx

* Please select when ordering

¹⁾ Restricted tolerances: Signal amplitude: 0.8 V_{PP} to 1.2 V_{PP}

²⁾ See also *Mechanical types and mounting* in the *Rotary Encoders* brochure

	Absolute	
	Singleturn	
	ROC 413	
Interface*	EnDat 2.2	SSI
Ordering designation	EnDat01	SSI01r1
Positions per revolution	8192 (13 bits)	
Revolutions	–	
Code	Pure binary	Gray
Electrically permissible speed Deviations ¹⁾	512 lines: ≤ 5000/12 000 rpm ±1 LSB/±100 LSB 2048 lines: ≤ 1500/12 000 rpm ±1 LSB/±50 LSB	12 000 rpm ±12 LSB
Calculation time t_{cal} Clock frequency	≤ 9 μs ≤ 2 MHz	≤ 5 μs –
Incremental signals	 1 V _{PP} ¹⁾	
Line counts*	512 2048	512
Cutoff frequency –3 dB	512 lines: ≥ 130 kHz; 2048 lines: ≥ 400 kHz	
System accuracy	512 lines: ±60"; 2048 lines: ±20"	
Supply voltage	DC 5 V ±0.25 V	
Power consumption (max.)	≤ 625 mW	≤ 600 mW
Current consumption (typical; without load)	85 mA	70 mA
Electrical connection	Cable (10 m) with 17-pin M23 coupling (male)	
Shaft	Solid shaft D = 6 mm	
Mechanically permissible speed n	≤ 10 000 rpm	
Starting torque (typical)	0.015 Nm (at 20 °C)	
Moment of inertia of rotor	≤ 4.4 · 10 ⁻⁶ kgm ²	
Shaft load ²⁾	Axial: ≤ 40 N; radial: ≤ 60 N at shaft end (see also <i>Mechanical design types and mounting</i> in the <i>Rotary Encoders</i> brochure)	
Vibration 55 Hz to 2000 Hz Shock 6 ms	≤ 300 m/s ² (EN 60068-2-6) ≤ 1500 m/s ² (EN 60068-2-27)	
Operating temperature	–20 °C to +80 °C	
Ambient temperature	–20 °C (stationary cable) to +60 °C	
Surface temperature	≤ 120 °C	
Protection EN 60529	IP66	
Explosion protection as per	DIN EN 60079-0; DIN EN 60079-1; DIN EN 60079-31	
Equipment group Category Explosive atmosphere Type of ignition protection Explosion group and subgroup	II 2 G (gas) and D (dust) db and tb IIC (maximum permitted gap < 0.5 mm) and IIIC	
Mass	≈ 0.7 kg	
ID number	815113-xx	815112-xx

* Please select when ordering

¹⁾ Restricted tolerances: Signal amplitude: 0.8 V_{PP} to 1.2 V_{PP}

Multitum ROQ 425		
EnDat 2.2		SSI
EnDat01		SSI07r1
4096		
Pure binary		Gray
512 lines: ≤ 5000/10000 rpm ±1 LSB/±100 LSB 2048 lines: ≤ 1500/10000 rpm ±1 LSB/±50 LSB		10000 rpm ±12 LSB
≤ 9 µs ≤ 2 MHz		≤ 5 µs –
512 2048		512
≤ 700 mW		≤ 675 mW
100 mA		88 mA
815116-xx		815115-xx

²⁾ See also *Mechanical types and mounting* in the *Rotary Encoders* brochure

ROC/ROQ/ROD 400 series

- Absolute and incremental rotary encoders
- Clamping flange
- Solid shaft for separate shaft coupling
- For use in potentially explosive atmospheres

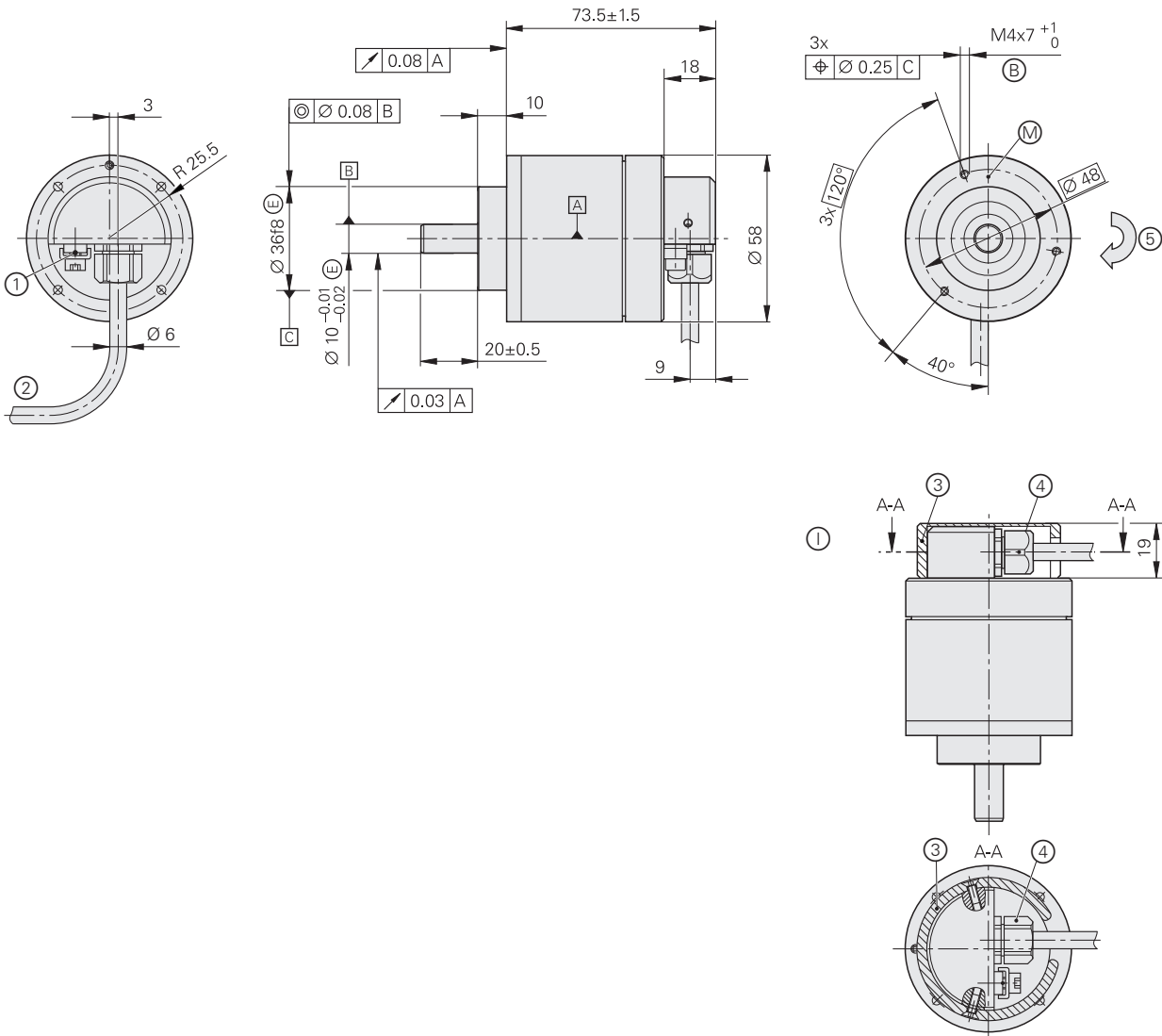

mm



Tolerancing ISO 8015

ISO 2768 - m H

< 6 mm: ±0.2 mm

▣ = Encoder bearing

⊕ = Threaded mounting hole

Ⓜ = Measuring point for operating temperature on encoder flange

1 = Connecting part for equipotential grounding and bonding according to DIN EN 60079-0



2 = Provide cable strain relief

3 = Protective cap

4 = Cable bushing for cable

5 = Direction of rotation for ascending position values

① = Additional means of protection for cable bushing that may be exposed to external load when the encoder is integrated vertically (Directive 2014/34/EU)

	Incremental		
	ROD 420	ROD 430	ROD 480
Interface	 TTL	 HTL	 1 V _{PP} ¹⁾
Line counts*	1000 1024 1250 1500 1800	2000 2048 2500 3600 4096	5000
Reference mark	One		
Cutoff frequency –3 dB Scanning frequency Edge separation <i>a</i>	– ≤ 300 kHz ≥ 0.39 μs		≥ 180 kHz – –
System accuracy	1/20 of grating period		
Supply voltage Current consumption without load	DC 5 V ±0.5 V ≤ 120 mA	DC 10 V to 30 V ≤ 150 mA	DC 5 V ±0.5 V ≤ 120 mA
Electrical connection	Cable (10 m) with 12-pin M23 coupling (male)		
Shaft	Solid shaft D = 10 mm		
Mechanically permissible speed <i>n</i>	≤ 10000 rpm		
Starting torque (typical)	0.015 Nm (at 20 °C)		
Moment of inertia of rotor	≤ 4.5 · 10 ⁻⁶ kgm ²		
Shaft load ²⁾	<i>Axial</i> : ≤ 40 N; <i>radial</i> : ≤ 60 N at shaft end		
Vibration 55 Hz to 2000 Hz Shock 6 ms	≤ 300 m/s ² (EN 60068-2-6) ≤ 1500 m/s ² (EN 60068-2-27)		
Operating temperature	–20 °C to +80 °C		
Ambient temperature	–20 °C (stationary cable) to +60 °C		
Surface temperature	≤ 120 °C		
Protection EN 60529	IP66		
Explosion protection as per	DIN EN 60079-0; DIN EN 60079-1; DIN EN 60079-31		
Equipment group Category Explosive atmosphere Type of ignition protection Explosion group and subgroup	II 2 G (gas) and D (dust) db and tb IIC (maximum permitted gap < 0.5 mm) and IIIC		
Mass	≈ 0.7 kg		
ID number	377237-xx	377238-xx	377240-xx

* Please select when ordering

¹⁾ Restricted tolerances: Signal amplitude: 0.8 V_{PP} to 1.2 V_{PP}

²⁾ See also *Mechanical types and mounting* in the *Rotary Encoders* brochure

	Absolute	
	Singleturn	
	ROC 413	
Interface*	EnDat 2.2	SSI
Ordering designation	EnDat01	SSI01r1
Positions per revolution	8192 (13 bits)	
Revolutions	–	
Code	Pure binary	Gray
Electrically permissible speed Deviations ¹⁾	<i>512 lines:</i> ≤ 5000/12 000 rpm ±1 LSB/±100 LSB <i>2048 lines:</i> ≤ 1500/12 000 rpm ±1 LSB/±50 LSB	12 000 rpm ±12 LSB
Calculation time t_{cal} Clock frequency	≤ 9 μs ≤ 2 MHz	≤ 5 μs –
Incremental signals	$\sim 1 V_{PP}$ ¹⁾	
Line counts*	512 2048	512
Cutoff frequency –3 dB	<i>512 lines:</i> ≥ 130 kHz; <i>2048 lines:</i> ≥ 400 kHz	
System accuracy	<i>512 lines:</i> ±60"; <i>2048 lines:</i> ±20"	
Supply voltage	DC 5 V ±0.25 V	
Power consumption (max.)	≤ 625 mW	≤ 600 mW
Current consumption (typical; without load)	85 mA	70 mA
Electrical connection	Cable (10 m) with 17-pin M23 coupling (male)	
Shaft	Solid shaft D = 10 mm	
Mechanically permissible speed n	≤ 10 000 rpm	
Starting torque (typical)	0.015 Nm (at 20 °C)	
Moment of inertia of rotor	≤ 4.5 · 10 ⁻⁶ kgm ²	
Shaft load ²⁾	<i>Axial:</i> ≤ 40 N; <i>radial:</i> ≤ 60 N at shaft end (see also <i>Mechanical design types and mounting</i> in the <i>Rotary Encoders</i> brochure)	
Vibration 55 Hz to 2000 Hz Shock 6 ms	≤ 300 m/s ² (EN 60068-2-6) ≤ 1500 m/s ² (EN 60068-2-27)	
Operating temperature	–20 °C to +80 °C	
Ambient temperature	–20 °C (stationary cable) to +60 °C	
Surface temperature	≤ 120 °C	
Protection EN 60529	IP66	
Explosion protection as per	DIN EN 60079-0; DIN EN 60079-1; DIN EN 60079-31	
Equipment group Category Explosive atmosphere Type of ignition protection Explosion group and subgroup	II 2 G (gas) and D (dust) db and tb IIC (maximum permitted gap < 0.5 mm) and IIIC	
Mass	≈ 0.7 kg	
ID number	815113-xx	815112-xx

* Please select when ordering

¹⁾ Restricted tolerances: Signal amplitude: 0.8 V_{PP} to 1.2 V_{PP}

Multiturn ROQ 425		
EnDat 2.2		SSI
EnDat01		SSI07r1
4096		
Pure binary		Gray
512 lines: ≤ 5000/10 000 rpm ±1 LSB/±100 LSB 2048 lines: ≤ 1500/10 000 rpm ±1 LSB/±50 LSB		10000 rpm ±12 LSB
≤ 9 µs ≤ 2 MHz		≤ 5 µs –
512 2048		512
≤ 700 mW		≤ 675 mW
100 mA		88 mA
815116-xx		815115-xx

²⁾ See also *Mechanical types and mounting* in the *Rotary Encoders* brochure

Electrical connection

Pin layout for SSI/EnDat 01

17-pin M23 coupling (male)



	Power supply				Incremental signals				Serial data transfer				Other signals
	7	1	10	4	15	16	12	13	14	17	8	9	3
	U_P	Sensor U_P	0V	Sensor 0V	A+	A-	B+	B-	DATA	$\overline{\text{DATA}}$	CLOCK	$\overline{\text{CLOCK}}$	$\overline{U_{aS}}$
	●————●		●————●										

Shield on housing; U_P = Power supply voltage

Sensor: the sense line is connected in the encoder with the corresponding power line

Pin layout for $\sim 1V_{PP}$ / \square TTL / \square HTL

12-pin M23 coupling (male)



	Power supply				Incremental signals						Other signals	
	12	2	10	11	5	6	8	1	3	4	7	9
$\sim 1V_{PP}$	U_P	Sensor U_P	0V	Sensor 0V	A+	A-	B+	B-	R+	R-	/	/
\square TTL					U_{a1}	$\overline{U_{a1}}$	U_{a2}	$\overline{U_{a2}}$	U_{a0}	$\overline{U_{a0}}$	$\overline{U_{aS}}$	/
\square HTL	●————●		●————●									

Shield on housing; U_P = Power supply voltage

Sensor: the sense line is connected in the encoder with the corresponding power line

Vacant pins or wires must not be used!

Connecting cables $\sim 1 V_{PP}$

TTL









HTL

EnDat

12-pin
M23

17-pin
M23

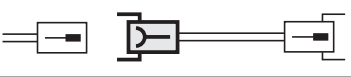
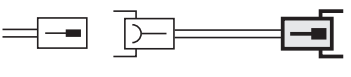
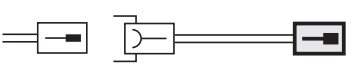
For $\sim 1 V_{PP}$ TTL HTL	For EnDat with SSI incremental signals
--------------------------------------	--

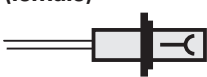
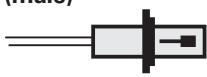
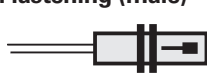
PUR adapter and connecting cables	12-pin: $4(2 \times 0.14 \text{ mm}^2) + (4 \times 0.5 \text{ mm}^2)$; $A_P = 0.5 \text{ mm}^2$ 17-pin: $(4 \times 0.14 \text{ mm}^2) + 4(2 \times 0.14 \text{ mm}^2) + (4 \times 0.5 \text{ mm}^2)$; $A_P = 0.5 \text{ mm}^2$	$\varnothing 8 \text{ mm}$ $\varnothing 8 \text{ mm}$
Connecting cable with M23 connector (female) and M23 coupling (male)		298401-xx 323897-xx
Connecting cable with M23 connector (female) and M23 connector (male)		298399-xx -
Adapter cable with M23 connector (female) and D-sub connector (female) for IK 220		310199-xx 332115-xx
Adapter cable with M23 connector (female) and D-sub connector (male) for IK 115/IK 215		310196-xx 324544-xx
Connecting cable with M23 connector (female)		309777-xx 309778-xx
Cable without connectors , $\varnothing 8 \text{ mm}$		244957-01 266306-01
Mating element on connecting cable to connector on encoder cable	Connector (female) for cable $\varnothing 8 \text{ mm}$ 	291697-05 291697-26
Connector on connecting cable for connection to subsequent electronics	Connector (male) for cable $\varnothing 4.5 \text{ mm}$ $\varnothing 8 \text{ mm}$ $\varnothing 6 \text{ mm}$ 	291697-06 291697-08 291697-07 291697-27
Coupling on connecting cable	Coupling (male) for cable $\varnothing 4.5 \text{ mm}$ $\varnothing 6 \text{ mm}$ $\varnothing 8 \text{ mm}$ 	291698-14 291698-03 291698-04 291698-25 291698-26 291698-27
Flange socket for mounting on subsequent electronics	Flange socket (female) 	315892-08 315892-10
Mounted couplings	With flange (female) $\varnothing 6 \text{ mm}$ $\varnothing 8 \text{ mm}$ 	291698-17 291698-07 291698-35
	With flange (male) $\varnothing 6 \text{ mm}$ $\varnothing 8 \text{ mm}$ 	291698-08 291698-31 291698-41 291698-29
	With central fastening (male) $\varnothing 6 \text{ mm}$ 	291698-33 291698-37

A_P : Cross section of power supply lines

HEIDENHAIN

DR. JOHANNES HEIDENHAIN GmbH

Dr.-Johannes-Heidenhain-Straße 5

83301 Traunreut, Germany

 +49 8669 31-0

 +49 8669 32-5061

E-mail: info@heidenhain.de

www.heidenhain.de

This Product Information document supersedes all previous editions, which thereby become invalid. The basis for ordering from HEIDENHAIN is always the Product Information document valid when the contract is made.



More information:

- Brochure: *Rotary Encoders* ID 349529-xx
- Brochure: *Interfaces of HEIDENHAIN Encoders* ID 1078629-xx
- Brochure: *Cables and Connectors* ID 1206103-xx