

ECI/EQI  
WELLA1: 82A

SCHNA1: EnDat01 / E30-R2

SCHNA1: EnDat22

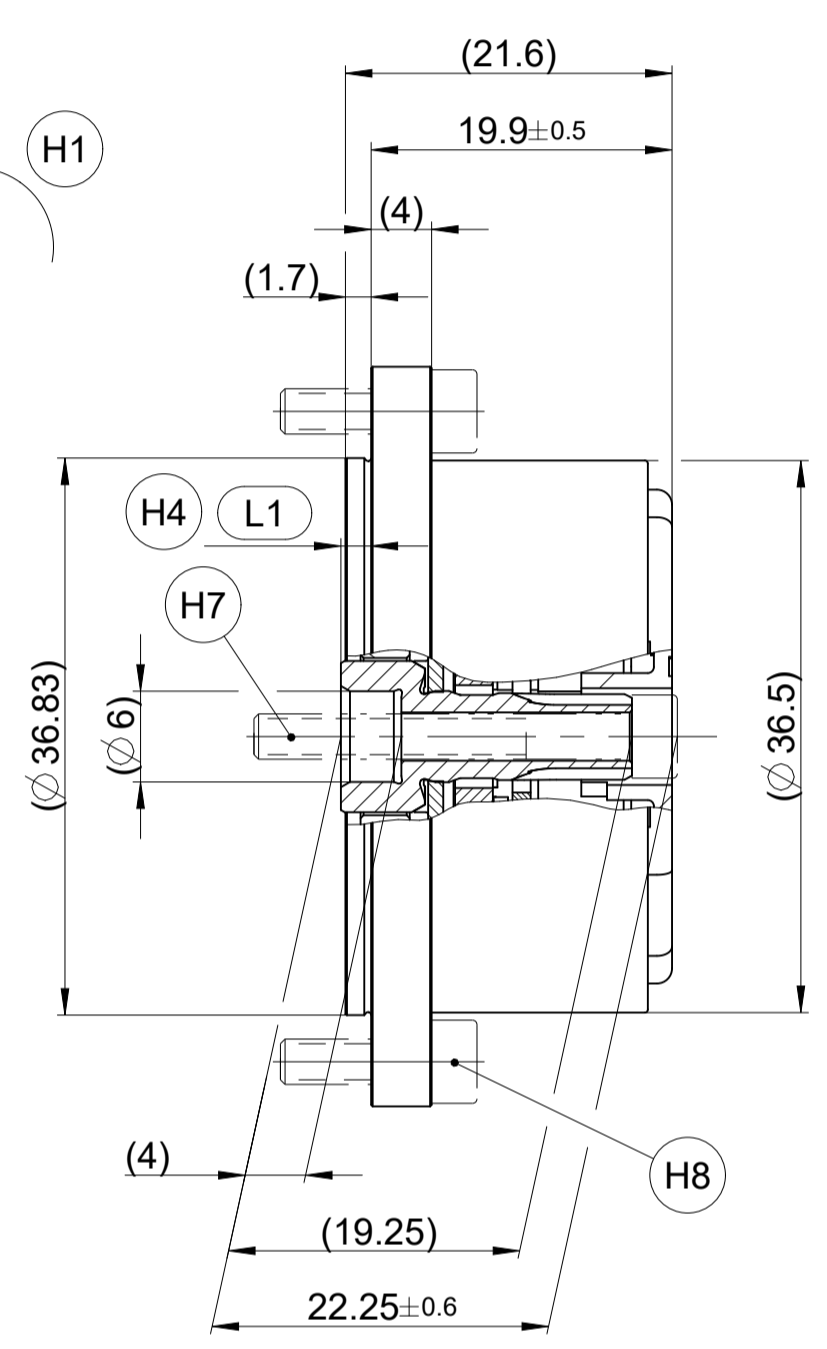
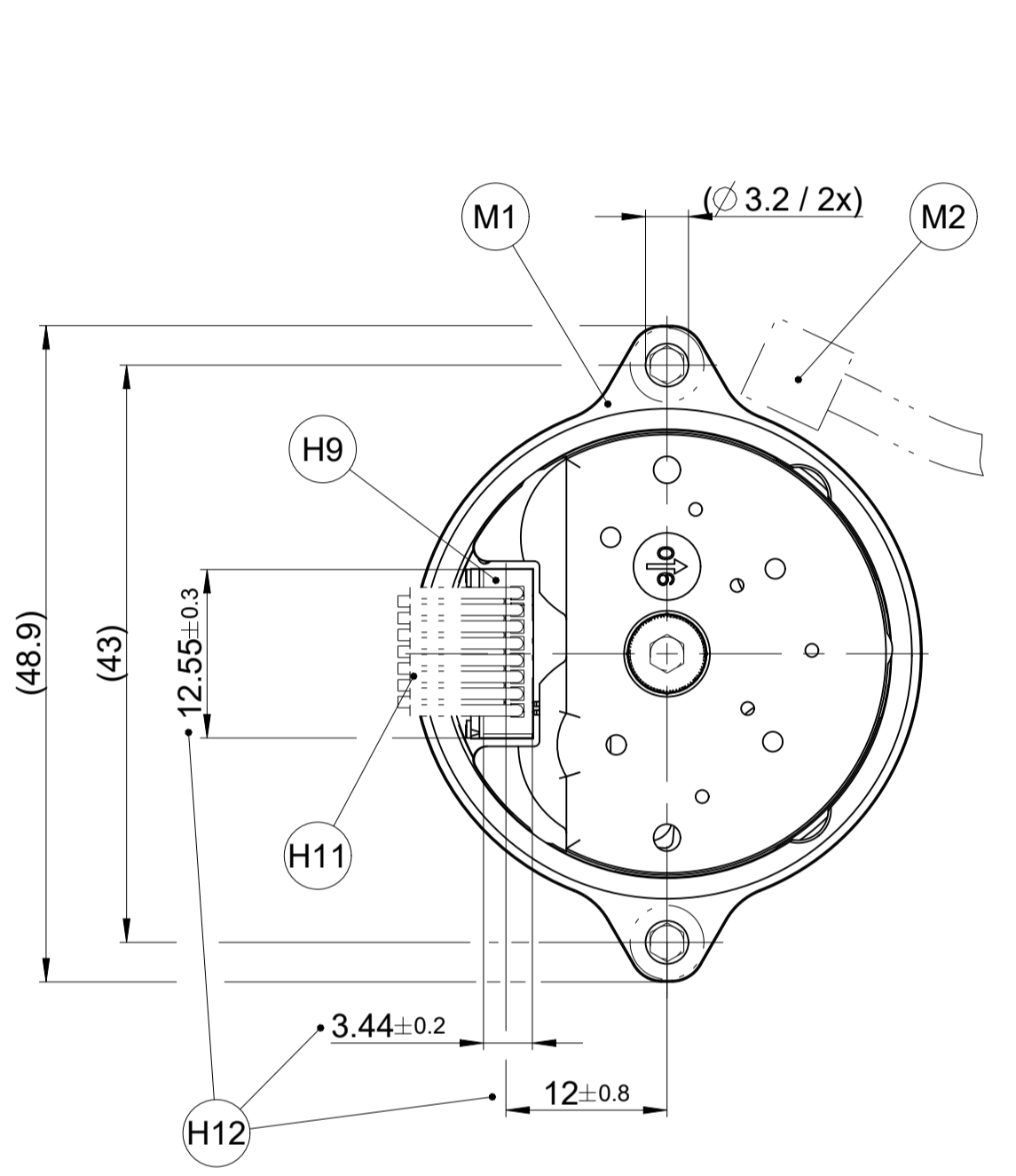
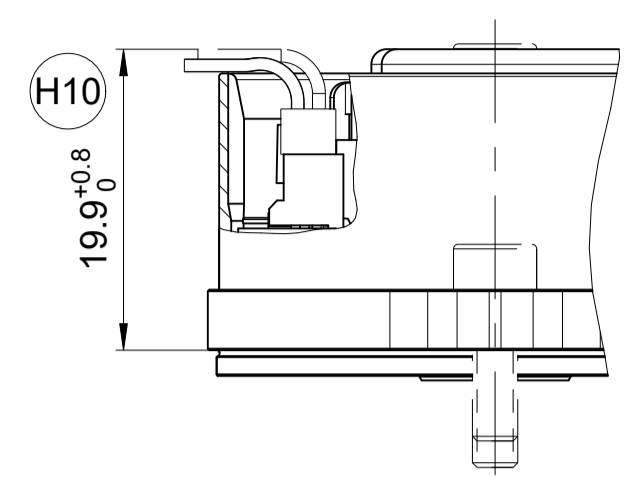
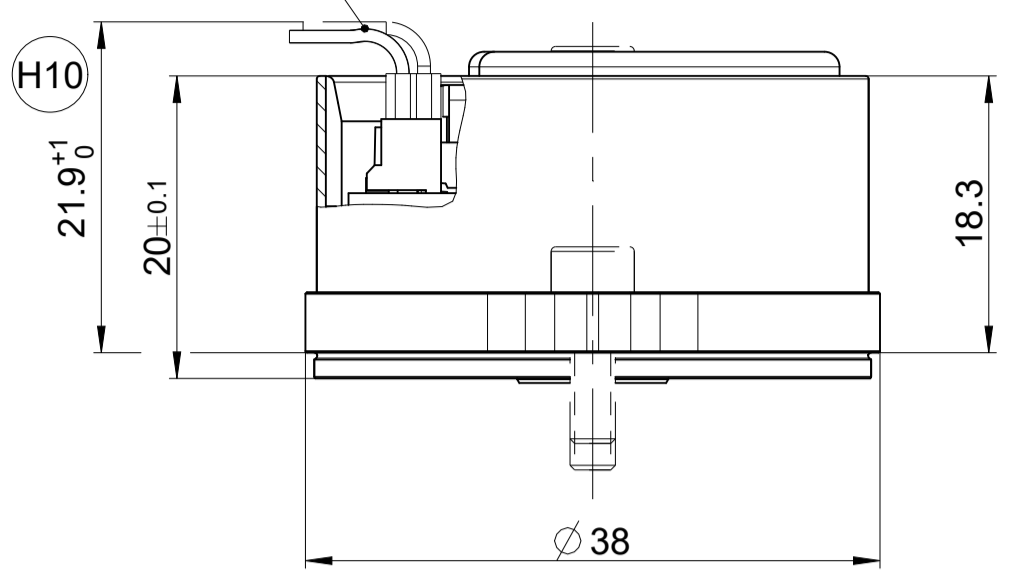

ECI/EQI  
WELLA1: 1KA

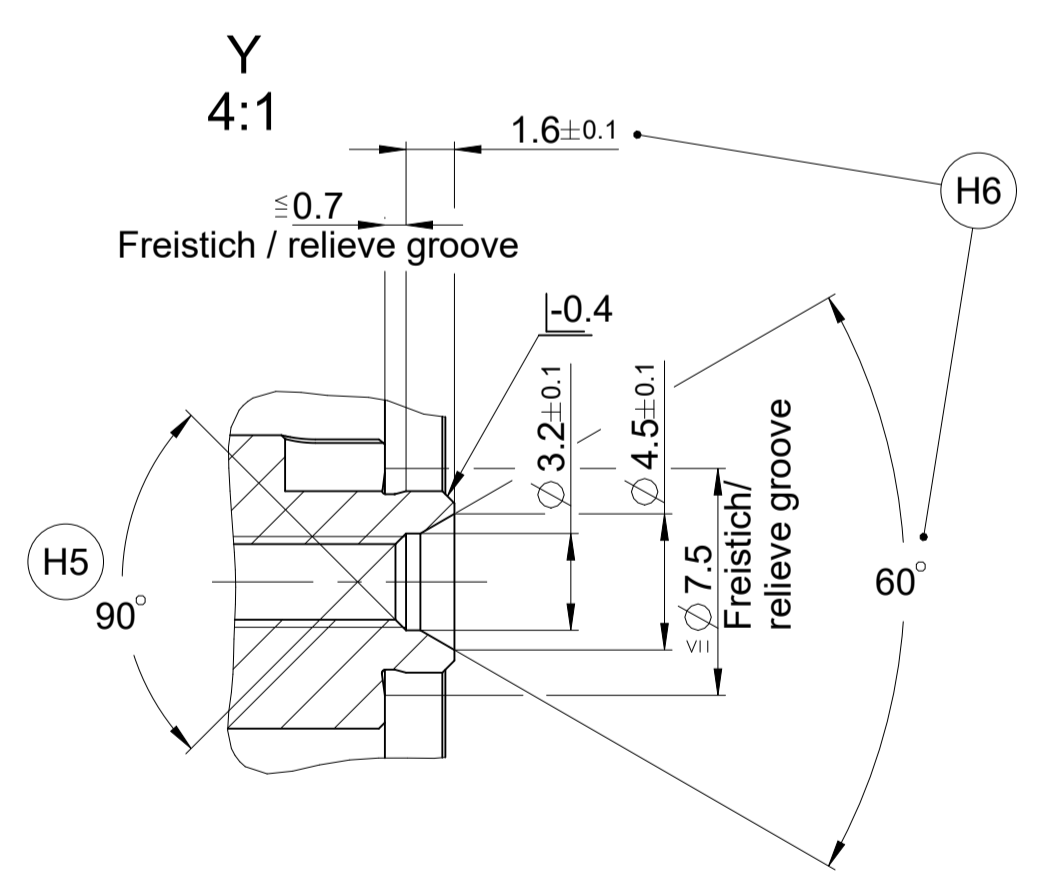
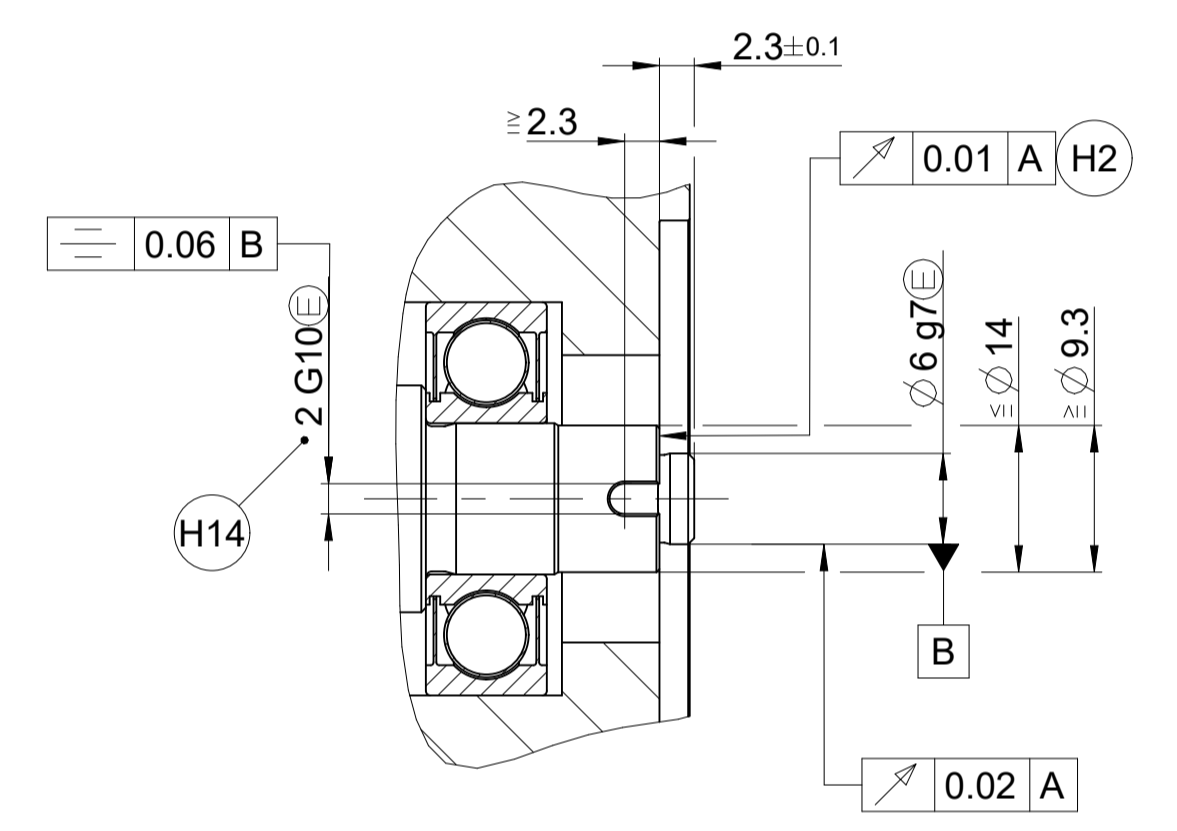
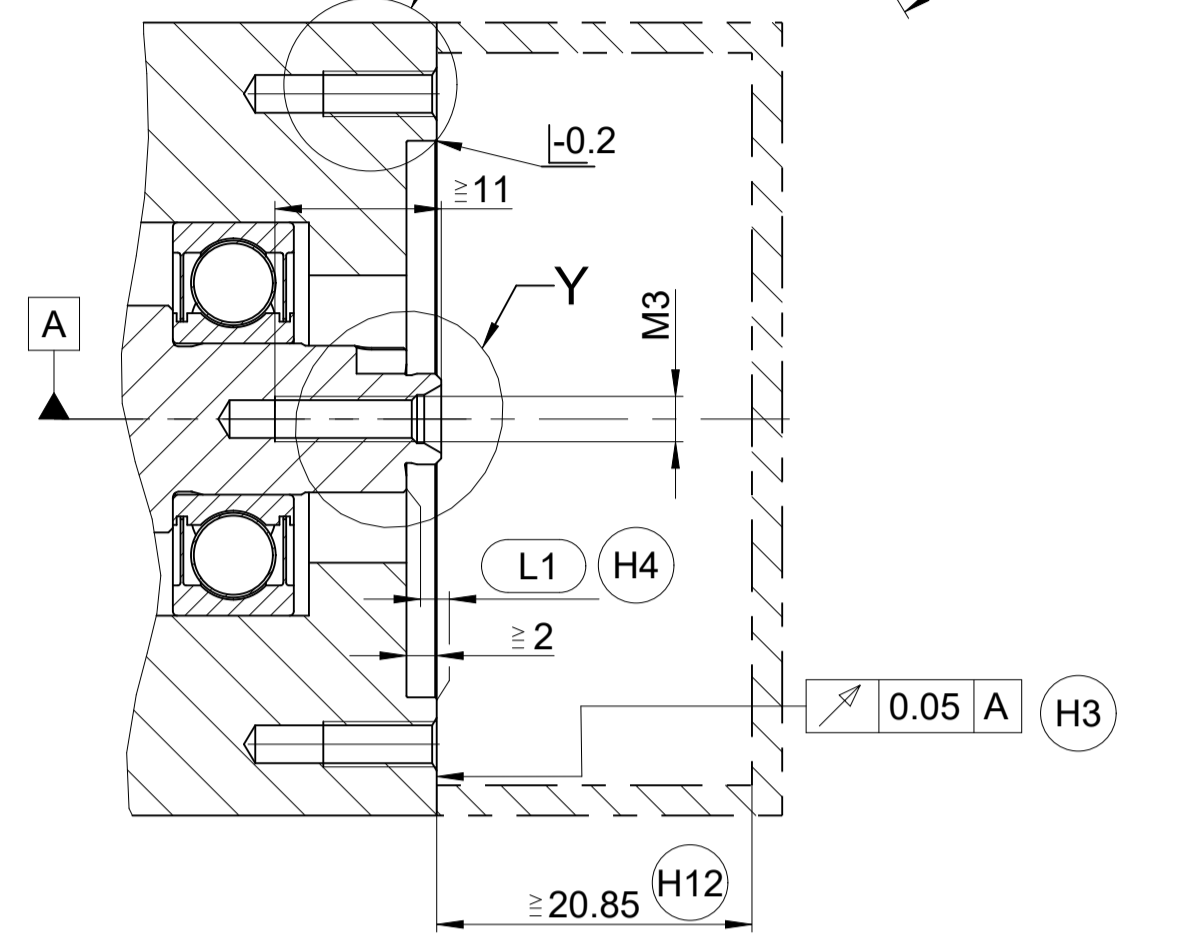
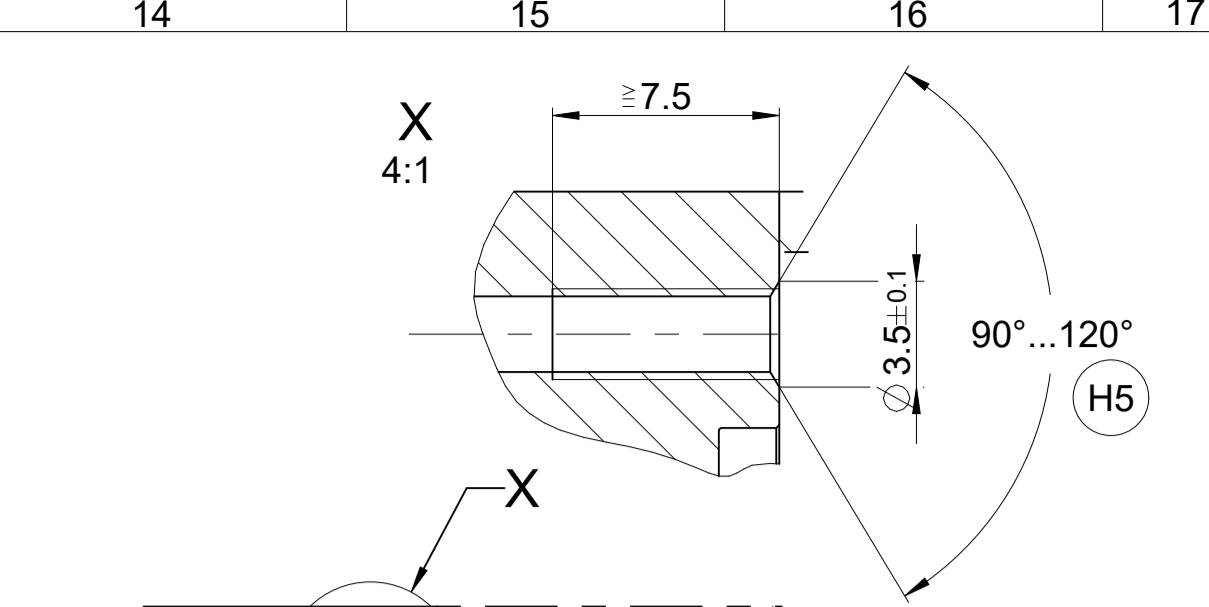
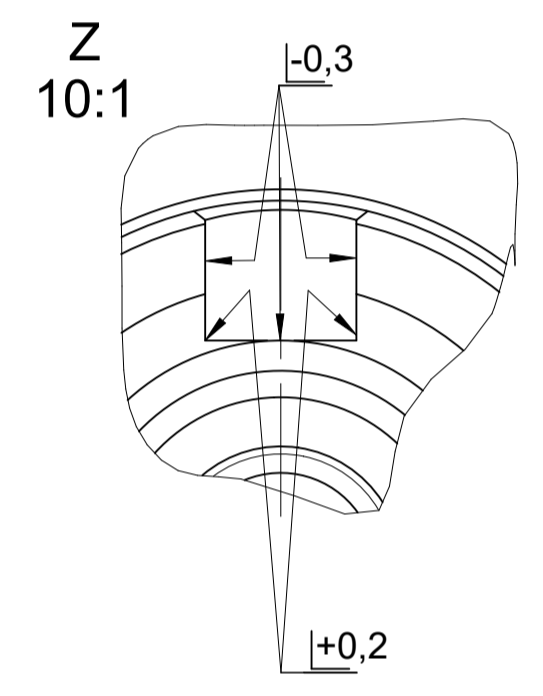
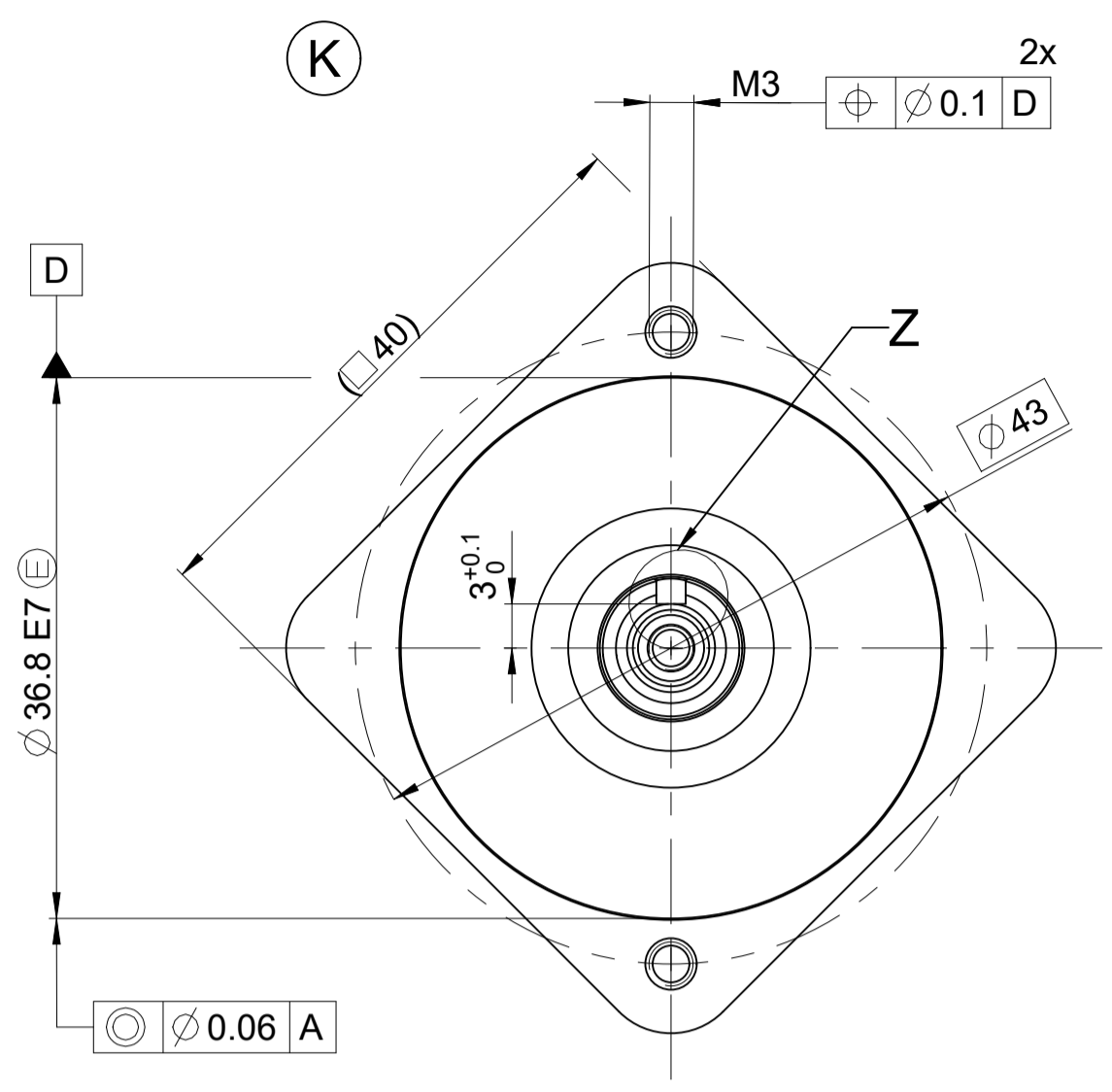
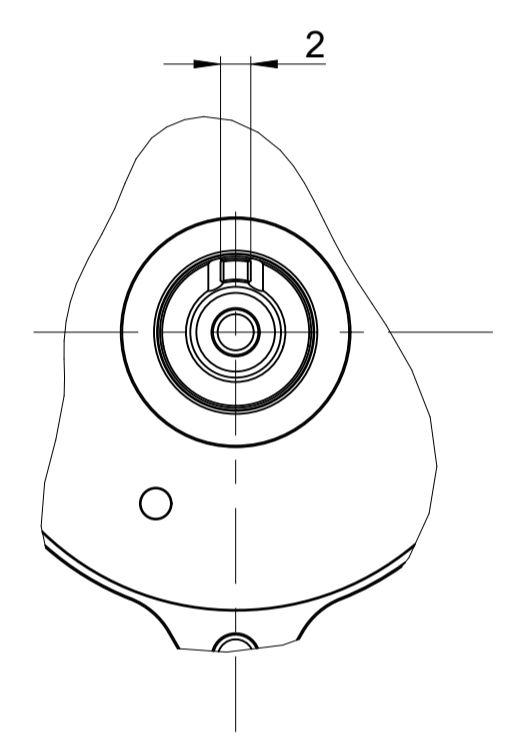
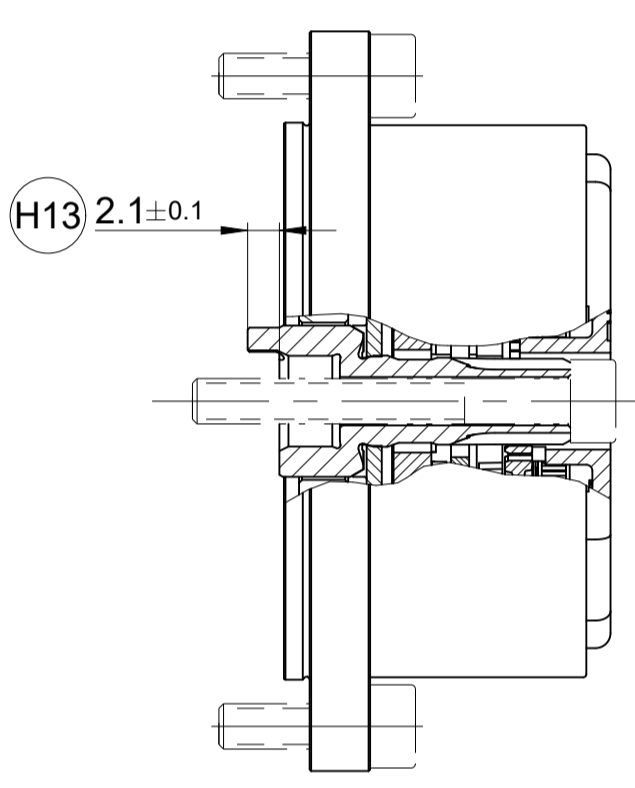

Für Funktionale Sicherheit und Mechanischen Fehlerausschluß obligatorisch  
For Functional Safety and mechanical fault exclusion is obligatory

Vorgaben nach den allgemeinen mechanischen Hinweisen  
im aktuellen Drehgeberkatalog (D349529)  
Specification according to general mechanical information  
in current brochures Rotary Encoders (ID D349529)

	Kundenwelle customer shaft	H15	Kundenstator mating stator
Werkstoffklasse Kundenseite Mating material class	Stahl oder Aluminium steel or aluminium		
*Gebrauchshinweise: Schraube mit stoffschlüssiger Losdrehicherung nach DIN 267-27 siehe Katalog "Allgemeine mechanische Hinweise" (nicht im Lieferumfang enthalten!) *References for use: Screw with materially bonding anti-rotation lock DIN 267-27 see brochure "general mechanical information" (not included in delivery!)			
			Anzugsmoment Tightening torque
H7	*M3x25 ISO 4762-8.8-MKL ID 202264-86		1,0 ±0,1Nm
H8	*M3x10 ISO 4762-8.8-MKL ID 202264-87		1,0 ±0,1Nm

- A = Lagerung Kundenwelle  
Bearing for customer shaft
- K = Kundenseitige Anschlussmaße  
Required mating dimensions
- M1 = Messpunkt Arbeitstemperatur  
Operating temperature measuring point
- M2 = Messpunkt Vibration  
Vibration measurement point
- H1 = Drehrichtung der Welle für Ausgangssignale gemäß Schnittstellenbeschreibung  
Sense of rotation für output signals due to interface specification
- H2 = Wellenanlage; Ganzflächige Auflage beachten!  
Shaft surface; Full bearing surface!
- H3 = Flanschanlage; Ganzflächige Auflage beachten!  
Flange surface; Full bearing surface!
- H4 = Maximal zulässige Abweichung zwischen Wellenanlage und Flanschanlage.  
Ausgleich von Montageteroleranzen und thermischer Ausdehnung.  
Dynamische Bewegung im gesamten Bereich zulässig.  
Maximum permissible deviation between shaft surface and flange surface. Compensation of mounting tolerances and thermal expansion. Dynamic motion permitted over entire range.
- H5 = Fase an Gewindeanfang obligatorisch für stoffschlüssige Losdrehicherung  
Chamfer is obligatory at start of thread for materially bonding anti-rotation lock

- H6 = Mögliche Zentrierbohrung  
Possible center hole
- H7 = M3 s. Tabelle/table
- H8 = M3 s. Tabelle/table
- H9 = Stiftleiste 15-pol.  
plug connector 15 pin
- H10 = Maßangabe für JH Standardkabel  
Dimension for JH standard cable
- H11 = Bauraum für Kabel beachten  
note the space required for cable
- H12 = Abstand zur Abdeckung;  
Ausbruch für Stiftleiste, Buchsenleiste und Litzen beachten  
Distance to cover;  
consider recess for plug connector, female connector and litz wires
- H13 = Formschlusselement - auf korrekten Eingriff in Nut achten,  
z.B. durch Messung des Geräteüberstands  
Positiv fit element - Ensure correct engagement in slot,  
e.g. by measuring the device overhang
- H14 = Nut nur für WELLA1=1KA nötig;  
Slot only required for WELLA1=1KA
- H15 = Blank. Keine Beschichtung zulässig  
Bare. No coating permitted

Werkstückkanten nach ISO 13715  
Workpiece edges ISO 13715

EQI / ECI	70C	1KA	FS	E30-R2	2±0.4
		82A	FS	EnDat22	2±0.4
		1KA	..	EnDat01	2±0.3
		82A	..		

NAME1	FLANA1	WELLA1	FUSIA1	SCHNA1	L1
-------	--------	--------	--------	--------	----

Original drawing	Scale	Format	Exl 11xx - FLANA1=70C Exl 11xx - FLANA1=70C	ID number: C078815-59
2:1	A1		Anschlussmaße / Mating Dimensions	Change No. Phase:
				Tolerances as per ISO 8015
				General Tolerances ISO 2768-1:2008-mH ±0.2