

SL, SR = segment length / Segmentlänge
 ≥ 20 ... ≤ 1000 = 1x remnant / Reststück (≥ 20 ... ≤ 1000)
 >1000 ... ≤ 1500 = 1x 499,5 + 1x remnant / Reststück (>500 ... ≤ 1000)
 >1500 ... ≤ 2000 = 1x 999,5 + 1x remnant / Reststück (>500 ... ≤ 1000)
 >2000 ... ≤ 2500 = 1x 499,5 + 1x 999,5 + 1x remnant / Reststück (>500 ... ≤ 1000)
 >2500 ... ≤ 3000 = 2x 999,5 + 1x remnant / Reststück (>500 ... ≤ 1000)
 >3000 ... ≤ 3500 = 1x 499,5 + 2x 999,5 + 1x remnant / Reststück (>500 ... ≤ 1000)
 etc.
 M = machine guideway / Maschinenführung
 ML = measuring length / Messlänge
 OL = overall length / Gesamtlänge
 \leftrightarrow = 0 ... ML
 \rightarrow + = direction of motion of the scanning unit for ascending position values
 Bewegungsrichtung des Abtastkopfes für steigende Positionswerte
 ⊙ = beginning of the measuring length ML / Beginn der Messlänge ML
 RI = selectable reference mark(s) / wählbare Referenzmarke(n)
 k = any position of the selected reference mark starting from the beginning of the ML
 beliebige Position der ausgewählten Referenzmarke vom Beginn der ML
 j = additional reference marks selectable every 50mm
 zusätzliche Referenzmarken alle 50mm auswählbar
 f = OL/2 (Standard)
 any position of the clamping element (optional)
 beliebige Position des Klemmelements (optional)
 C = cable / Anschlusskabel
 (K) = required mating dimensions / kundenseitige Anschlussmaße
 L = LED function control / LED Funktionskontrolle
 R = bending radius / Biegeradius stat. R ≥ 8mm, dyn. R ≥ 20mm
 S1, S2 = switch signal / Schaltsignal
 n = 1,2,3,...(number of segments / Anzahl der Segmente)

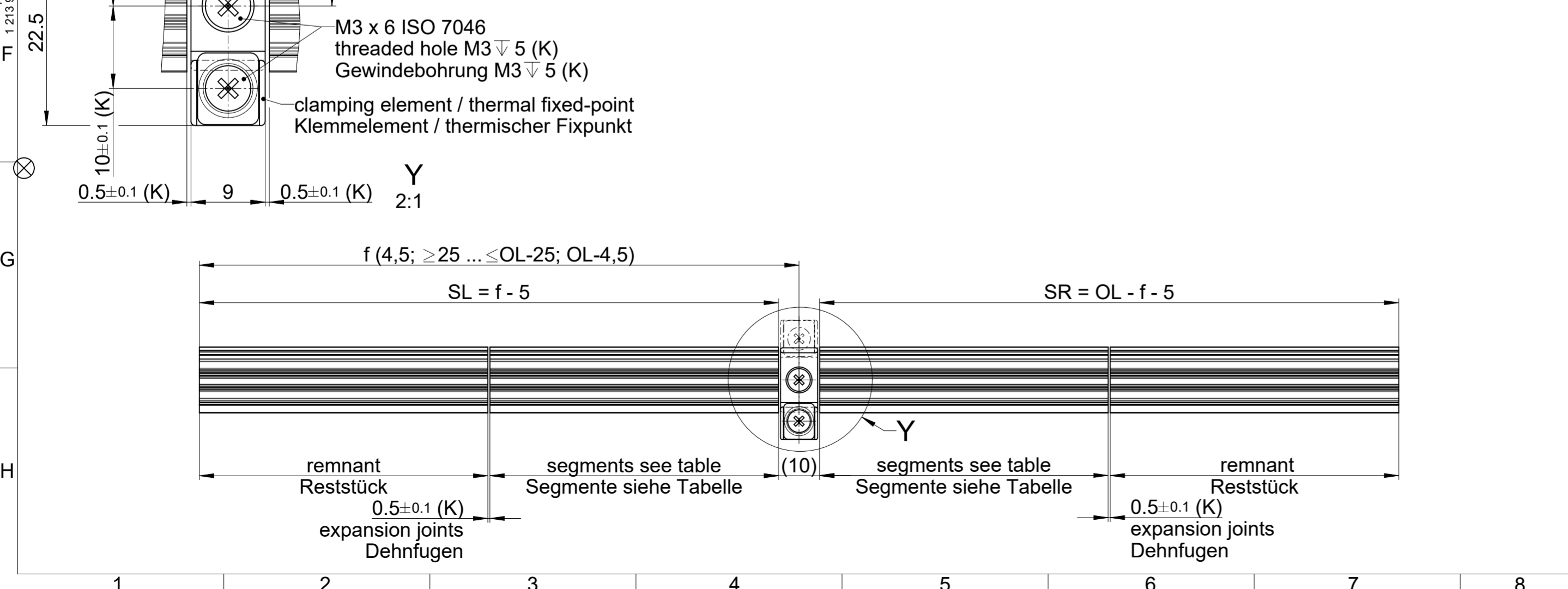

Permissible position deviation scanning head - tape scale A B

Zulässige Lageabweichungen Abtastkopf - Maßband A B

Δz = ± 0.2mm (gap / Abstand)

Δy = ± 0.5mm (lateral / Verschiebung)

φz = ± 1.00mrad or / oder ± 0.06° (yaw angle / Gierwinkel)

φy = ± 3.50mrad or / oder ± 0.20° (pitch angle / Nickwinkel)

φx = ± 4.00mrad or / oder ± 0.23° (roll angle / Rollwinkel)

Original drawing		MS15 MP		ID number: -
Scale		MS15 MP		Change No. C157360-30
Format		Anschlussmaße / Mating Dimensions		Phase: Serie
Dimensions in mm		1:1 A2		Tolerances as per ISO 8015
				General Tolerances ISO 2768:1989-mH ≤ 6:±0.2
The reproduction, distribution and utilization of this document as well as the communication of its contents to others without express authorization is prohibited. Offenders will be held liable for the payment of damages. All rights reserved in the event of the grant of a patent, utility model or design. (ISO 16016)				
Released		Version		Revision
21.06.2024		D1171349-03-B-01		Sheet 1 of 1
www.rsfelektronik.at		Document number		Page 1 of 1