

- F = Maschinenführung Machine guideway
- \* = max. Änderung bei Betrieb Max. change during operation
- ML = Messlänge Measuring length
- (E) = Epoxy bei ML < 170 Epoxy for ML < 6.7"
- (LI) = Limitmarke, verstellbar Limit-Label, adjustable
- (H) = Schalter für Homingspur Switch for homing track
- Ho = Schaltpunkt Homing Trigger point homing
- (R) = Referenzmarken-Lage Reference mark position
- (S) = Beginn der Messlänge Begin. of meas. length
- (T) = Anschlagfläche Maßstab stop surface scale

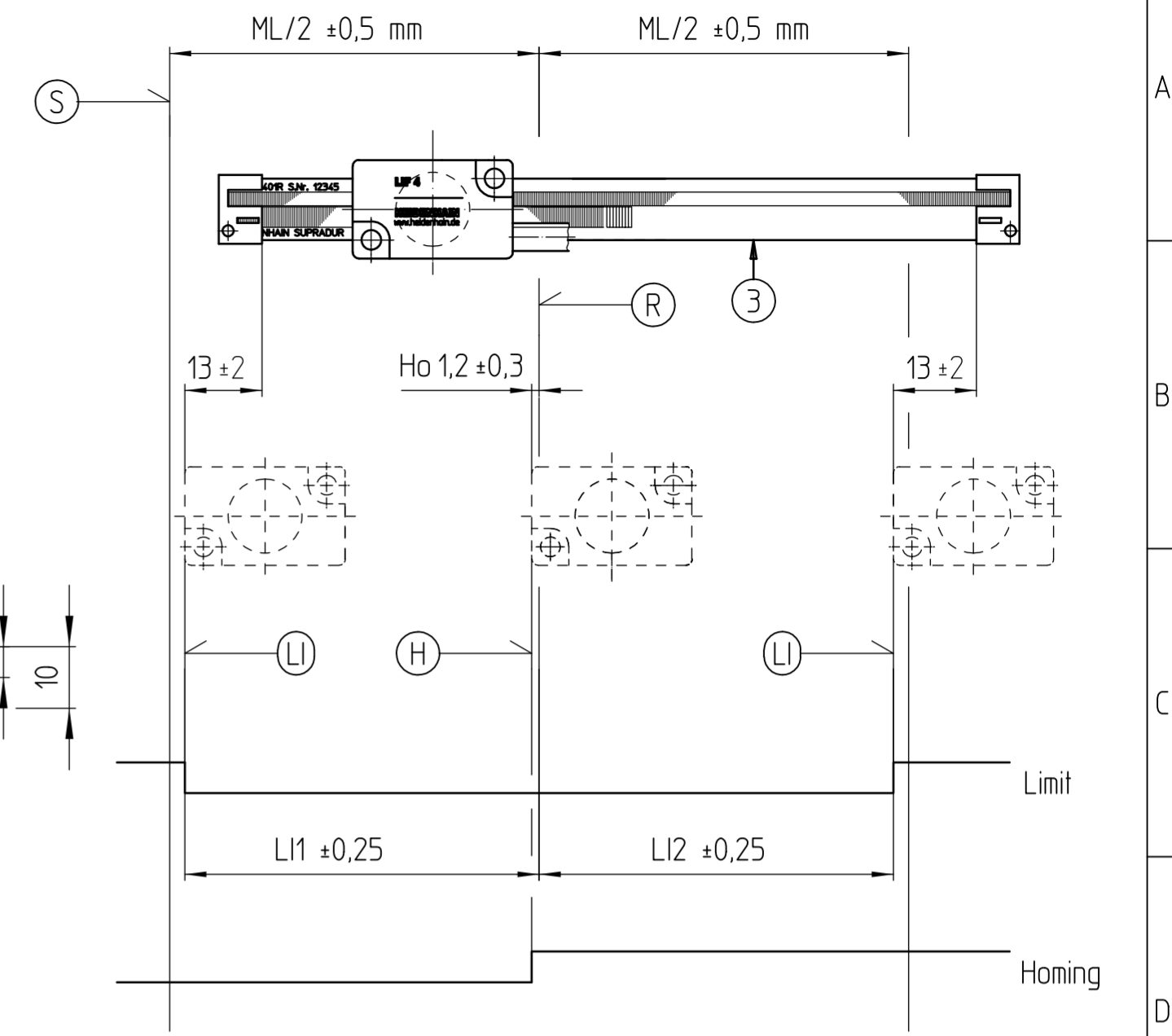

Homingfunktion ab ML > 5mm  
Homingfunction at ML > 5mm

Limitfunktion ab ML > 10mm  
Limitfunction at ML > 10mm

Position Anschlagstifte  
Position stop pins

