

Außenring nicht als Rotor benutzen!
Don't use outer ring as rotor part!

(K) Kundenseitige Anschlussmaße
Required mating dimensions

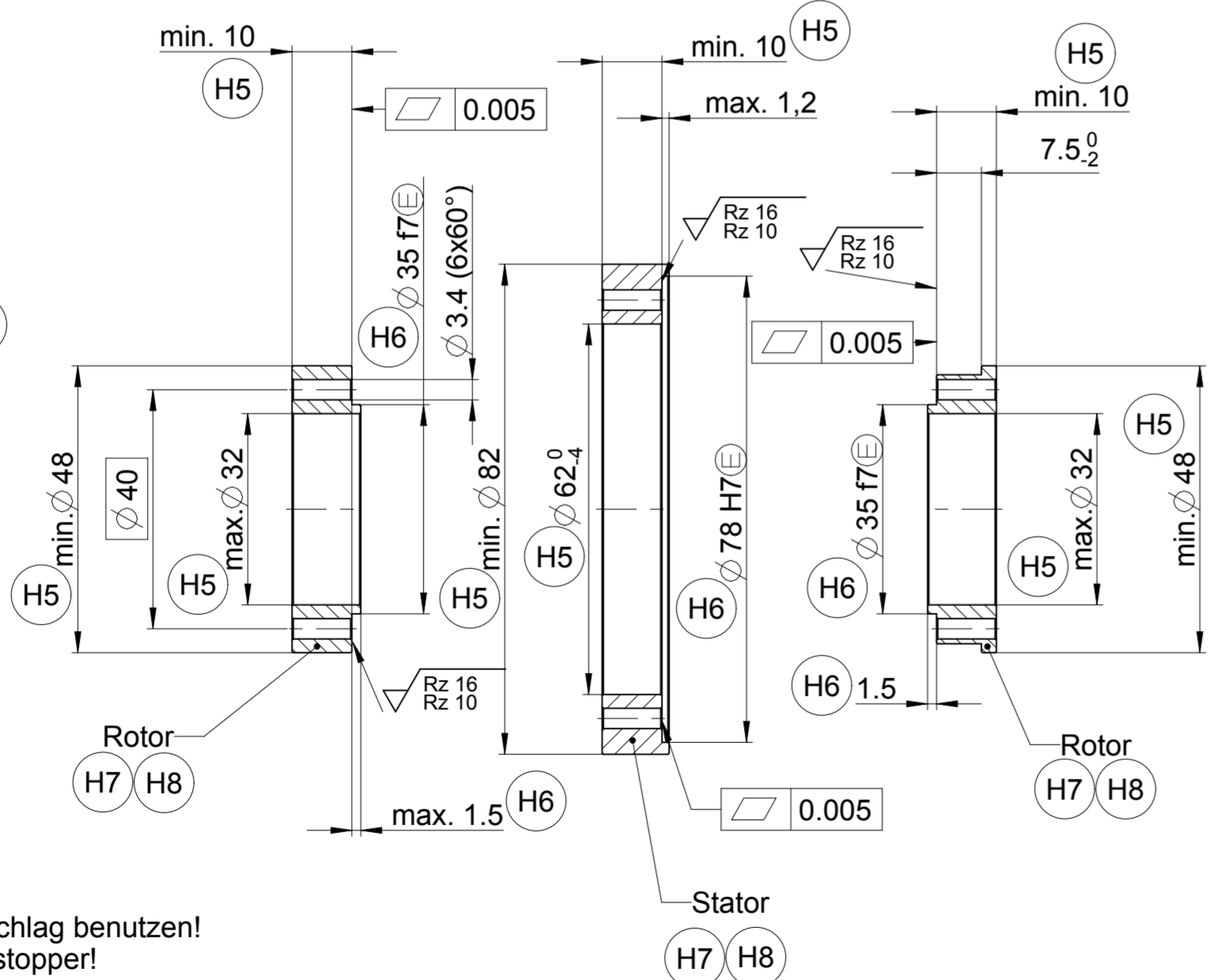
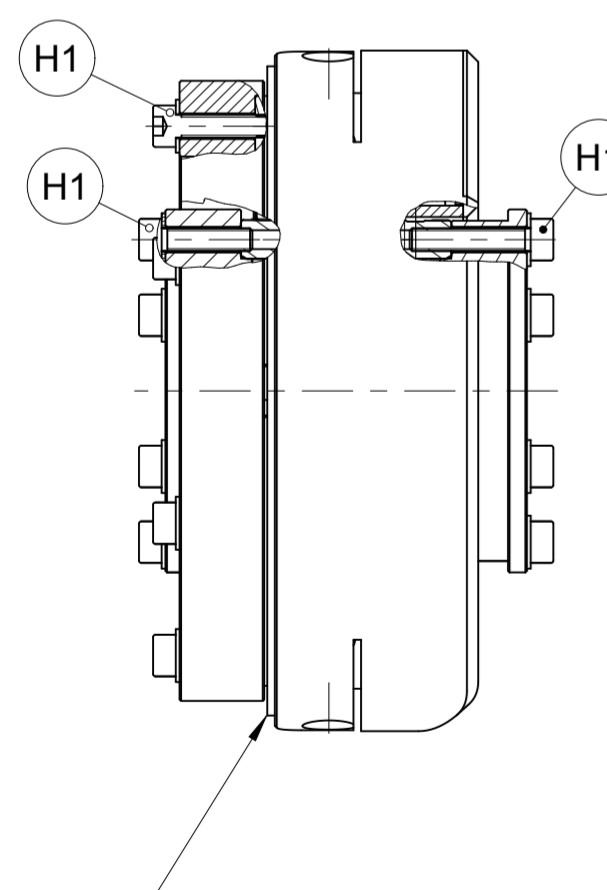

Kante nicht als Anschlag benutzen!
Don't use edge as stopper!

Montageflächen und Gewinde müssen sauber und fettfrei sein
Mounting surfaces and threads must be clean and free of grease

- (K) = Kundenseitige Anschlussmaße
Required mating dimensions
- (H1) = Anziehdrehmomente der Zylinderschrauben M3:
1,1 ± 0,05 Nm
Schraube: ISO 4762
Schraubenfestigkeitsklasse 8.8
Scheibe:
ISO 7092-3-200HV
Stoffschlüssige Schraubenlosdrehung erforderlich
Tightening torque of the screws M3:
1,1 ± 0,05 Nm
Screw: ISO 4762
Screw property class 8.8
Washer:
ISO 7092-3-200HV
Materially bonding anti-rotation lock necessary
- (H2) = Markierung der 0° Position ± 5°
0° position index ± 5°
- (H4) = Drehachse der Welle für Ausgangssignale gemäß Schnittstellen-Beschreibung
Direction of shaft rotating for output signals as per the interface description
- (H5) = erforderliche Kunden-Anbaumaße zur Übertragung der maximal zulässigen Belastungen gemäß den Technischen Daten
Required customer's mounting dimensions to transmit the maximum allowed loads as per the technical data
- (H6) = optional empfohlene Kunden-Anbaumaße
optional recommended customer's mounting dimensions
- (H7) = Material für Kundenanbauteile: Stahl
Re >= 235 N/mm² Rm >= 400 N/mm²
Material of customer's parts: Steel
Re >= 235 N/mm² Rm >= 400 N/mm²
- (H8) = Thermischer Ausdehnungskoeffizient:
(10α<math><16)</math> x 10⁻⁶/K
Coefficient of thermal expansion
(10α<math><16)</math> x 10⁻⁶
- (H9) = empfohlene Krafrichtung;
wenn dynamische Überlastungen möglich sind,
ist die empfohlene Krafrichtung einzuhalten
recommended direction of axial forces;
if dynamic overloads are possible, the recommended
direction of axial forces must be observed

Original drawing		Scale		Format		MRP 5010		ID number: 1101636-01	
1:1		A2				MRP		Change No. C042888-05	
Dimensions in mm						Anschlussmaße / Mounting Dimensions		Phase: Serie	
								Tolerierung nach DIN ISO 8015	
								Tolerances as per DIN ISO 8015	
								Allgemeintol. ISO 2768-mH ±0,2	
								General tol. ISO 2768-mH ±0,2	
								The reproduction, distribution and utilization of this document as well as the communication of its contents to others without express authorization is prohibited. Offenders will be held liable for the payment of damages. All rights reserved in the event of the grant of a patent, utility model or design. (ISO 16016)	
								Version Revision Sheet Page	
								1 1 1 1	
								D1107083-05 - A-01	
								Document number	

HEIDENHAIN
DR. JOHANNES HEIDENHAIN GmbH
83301 Traunreut, Germany