

**Warnhinweise**  
**Warnings**  
**Avertissements**  
**Avvertenze**  
**Advertencias**

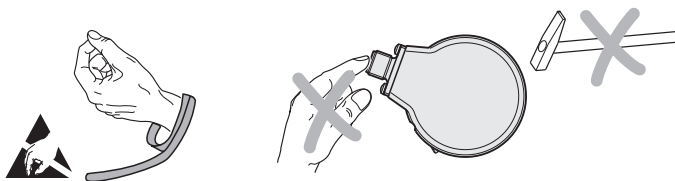

**Achtung:** Die Montage und Inbetriebnahme ist von einer qualifizierten Fachkraft unter Beachtung der örtlichen Sicherheitsvorschriften vorzunehmen.

Zusätzlich muss der Maschinenhersteller/-konstrukteur die erforderlichen weiteren Angaben zur Endmontage (z.B. Losdreh Sicherung für Schrauben ja/nein) für die jeweilige Anwendung selbst festlegen. Die Steckverbindung darf nur spannungsfrei verbunden oder gelöst werden. Die Anlage muss spannungsfrei geschaltet sein!

**Note:** Mounting and commissioning is to be conducted by a qualified specialist under compliance with local safety regulations.

In addition to this, the machine manufacturer or designer himself must define the other data required for final assembly (e.g. anti-rotation lock for screws required or not) for the respective application.

Do not engage or disengage any connections while under power.

The system must be disconnected from power.

**Attention:** le montage et la mise en service doivent être assurés par un personnel qualifié dans le respect des consignes de sécurité locales.

D'autre part, le fabricant/constructeur de la machine doit définir d'autres données nécessaires au montage final (p.ex. sécurité frein de vis oui/non) pour l'application respective.

Le connecteur ne doit être connecté ou déconnecté qu'hors potentiel.

L'équipement doit être connecté hors potentiel!

**Attenzione:** Il montaggio e la messa in funzione devono essere eseguite da personale qualificato nel rispetto delle norme di sicurezza locali.

Inoltre, il costruttore della macchina deve definire le ulteriori procedure necessarie per completare il montaggio (ad esempio: sicurezza allentamento viti sì/no) di ogni specifica applicazione.

I cavi posso essere collegati o scollegati solo in assenza di tensione.

L'impianto deve essere spento!

**Atención:** El montaje y la puesta en marcha deben ser realizados por un especialista cualificado, observando las prescripciones locales de seguridad.

Adicionalmente, el fabricante/constructor de la máquina debe determinar él mismo el resto de indicaciones requeridas para el montaje final para cada aplicación en particular (p.ej., seguro antigiro para tornillos sí/no).

Conectar o desconectar el conector sólo en ausencia de tensión.

¡La instalación debe ser conectada en ausencia de tensión!

Ø 3.7 mm	Ø 6 mm		
R <sub>1</sub> ≥ 8 mm	R <sub>1</sub> ≥ 20 mm	R <sub>1</sub>	R <sub>2</sub>
R <sub>2</sub> ≥ 40 mm	R <sub>2</sub> ≥ 75 mm		

Biegeradius Kabel **R**  
 Bending radius Cables **R**  
 Rayon de courbure **R**  
 Piegatura **R**  
 Radio de curvatura **R**

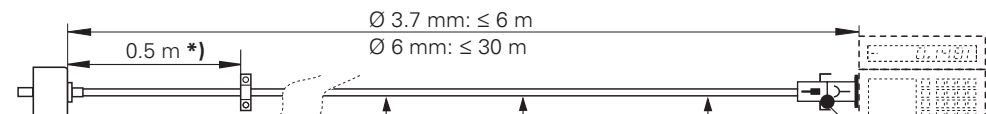

\*) Kabel durch Zugentlastung sichern  
 Secure cable with strain relief  
 Consolider le câble per décharge de traction  
 Fissare il cavo con fermacavo  
 Asegurar el cable mediante la descarga de tracción

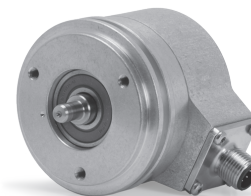
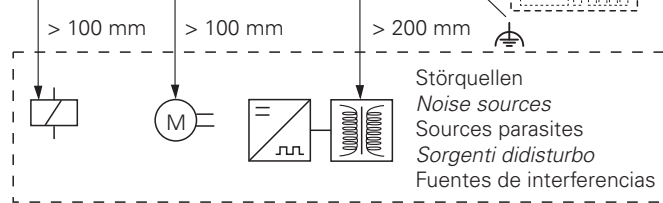

Drehgeber für separate Wellenkupplung.  
 Rotary encoders for separate shaft coupling.  
 Capteurs rotatifs pour accouplement d'arbre séparé.  
 Encoder con giunto albero separato.  
 Generador rotativo acoplamiento al eje por separado.



[www.heidenhain.de/documentation](http://www.heidenhain.de/documentation)

# HEIDENHAIN

Montageanleitung  
 Mounting Instructions  
 Instructions de montage  
 Istruzioni di montaggio  
 Instrucciones de montaje

**ROC 425F**  
**ROC 425M**  
**ROQ 437F**  
**ROQ 436F**  
**ROQ 435M**

WELLA1: 73A  
 FLANA1: 01C  
 ANELA1: 5XS08  
 BELEA1: C4

06/2018



**Lieferumfang:**  
**Items supplied:**  
**Objet de la fourniture:**  
**Standard di fornitura:**  
**Suministro:**

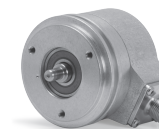

Separat bestellen:  
 Order separately:  
 Commander séparément:  
 Ordinare separatamente:  
 Pedir por separado:



Spannpratzen (3 Stück nötig)  
 Fixing clamps (3 required)  
 Griffes de montage (3 pièces nécessaires)  
 Graffette (necessari 3 pezzi)  
 Mordazas (se requieren 3 piezas)  
 ID 200032-01

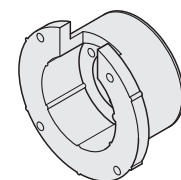

Montageglocke  
 Adapter flange  
 Cloche de montage  
 Campana di montaggio  
 Campana de montaje  
 ID 257044-01

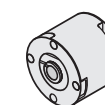

Membrankupplung K 17  
 Diaphragm coupling K 17  
 Accouplement à membrane K 17  
 Giunto a membrana K 17  
 Acoplamiento de membrana K17  
 ID 296746-xx

**DR. JOHANNES HEIDENHAIN GmbH**

Technical support, measuring systems ☎ +49 8669 31-3104 · E-mail: [service.ms-support@heidenhain.de](mailto:service.ms-support@heidenhain.de)

1092437-92 · Ver02 · Printed in Germany · 06/2018 · H



**Anbaumaße (mm)**  
**Mounting Dimensions (mm)**  
**Cote d'encombrement (mm)**  
**Dimensioni di montaggio (mm)**  
**Medidas para el montaje (mm)**

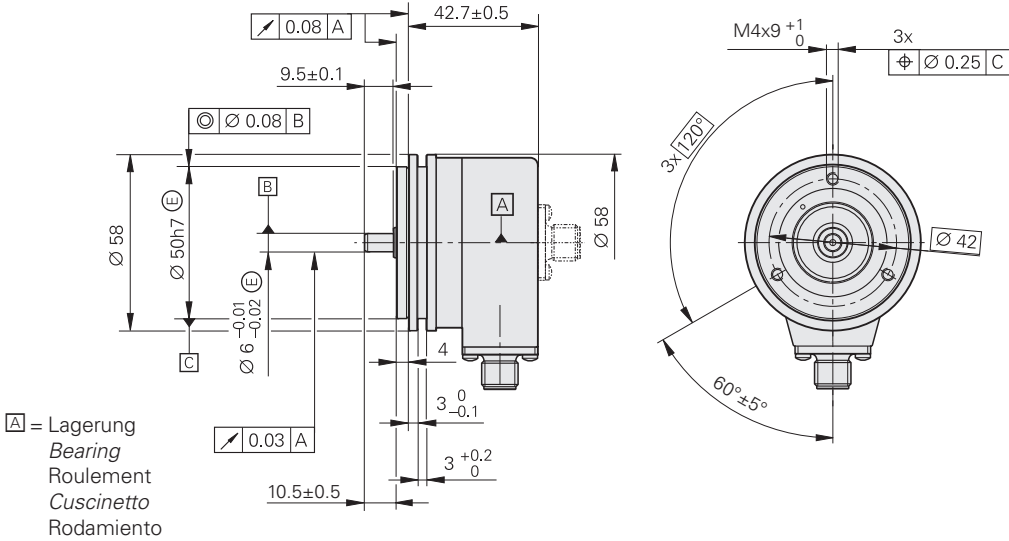

**Anschlussbelegung**  
**Pin Layout**  
**Affectation des plots**  
**Piedinatura**  
**Distribución del conector**

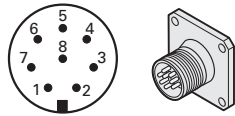

Außenschirm mit Gehäuse verbunden  
 External shield connected to housing  
 Blindage extérieur connecté au boîtier  
 Schermo del cavo collegato alla carcassa  
 Apantallado exterior unido a la carcassa

**ROx 4xxF:**

8	2	5	1	3	4	7	6
U <sub>P</sub>	Sensor U <sub>P</sub>	0V	Sensor 0V	Serial Data	Serial Data	Request	Request
BNGN	BU	WHGN	WH	GY	PK	VT	YE

**ROx 4xxM:**

8	2	5	1	3	4	7	6
U <sub>P</sub>	Sensor U <sub>P</sub>	0V	Sensor 0V	Serial Data	Serial Data	Request Frame	Request Frame
BNGN	BU	WHGN	WH	GY	PK	VT	YE

Die Sensorleitung ist intern im Messgerät mit der Versorgungsleitung verbunden.  
 The sensor line is connected inside the encoder to the supply line.  
 La ligne de palpeur est reliée de manière interne dans le système de mesure à la ligne d'alimentation.  
 La linea del sensore è collegata internamente allo strumento di misura con la linea di alimentazione.  
 La línea de sensor está unida internamente en el aparato de medida con la línea de alimentación.

**Montage**  
**Assembly**  
**Montage**  
**Montaggio**  
**Montaje**



**Achtung:** Verletzungsgefahr durch drehende Teile.  
 Auf Berührungsschutz achten!  
**Warning:** Risk of injury from rotating parts.  
 Protect against contact!  
**Attention:** danger de blessures par des pièces en rotation.  
 Prévoir une protection au contact!  
**Attenzione:** pericolo di lesioni da pezzi rotanti.  
 Mettere protezioni per impedire il contatto!  
**Atención:** riesgo de accidente por causa de piezas en rotación.  
 ¡Considerar una protección ante contacto accidental!

Wellen auf Versatz überprüfen  
 Check shafts for offset  
 Contrôler le désaxage de l'arbre  
 Verificare disallineamento albero  
 Controlar desplazamiento del eje

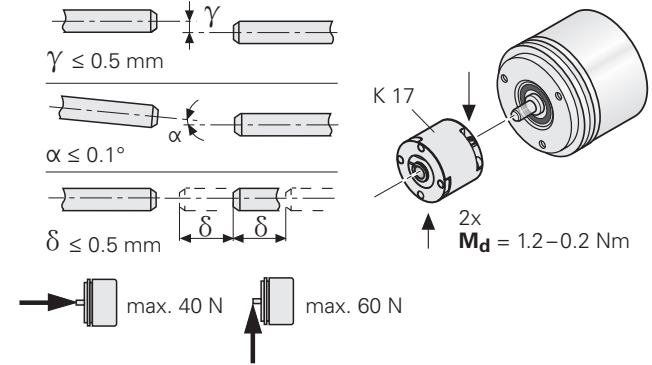

⓪

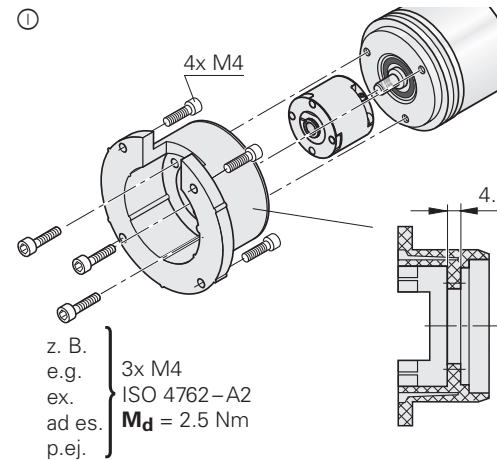

⓪, ⊕ = Anbaumöglichkeiten  
 Mounting possibilities  
 Options de montage  
 Possibilità di montaggio  
 Posibilidades de instalación

⓪

