

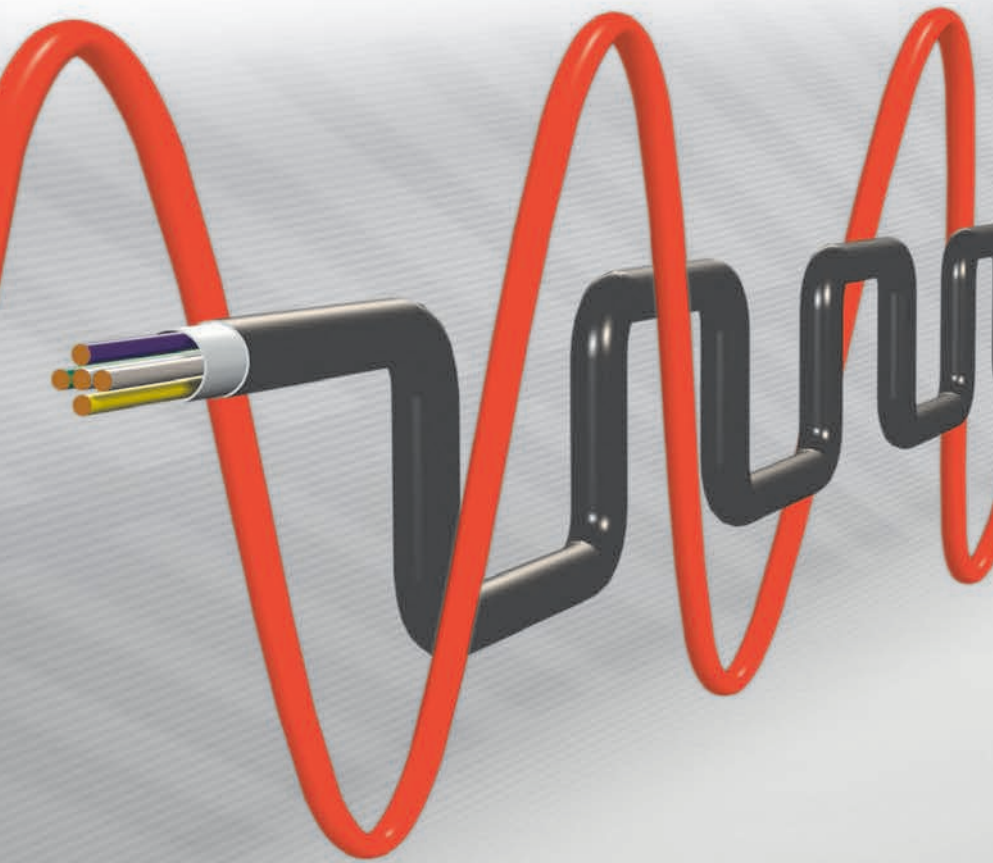

HEIDENHAIN



Interfaces of HEIDENHAIN Encoders

Interfaces

As the defined link between encoders and downstream electronics, interfaces ensure the reliable exchange of information.

HEIDENHAIN offers encoders with interfaces for many common downstream electronics. The specific interface that can be used depends on the encoder's method of measurement and other factors.

Methods of measurement

In the **incremental measuring method**, the position information is obtained **by counting** the individual increments (measuring steps) starting from a selected point of origin. An absolute reference point is needed for determining the position, so a reference-mark signal is output as well. Incremental encoders generally output **incremental signals**. Some incremental encoders with integrated signal converters have a counting function: once the reference mark is traversed, an absolute position value is generated and transmitted via a serial interface.

In the **absolute measuring method**, the absolute position information is acquired directly **from the grating of the measuring standard**. The position value is available

Note:

Specialized encoders can have other interface characteristics (e.g., with regard to shielding).

from the encoder immediately upon switch-on and can be requested at any time by the downstream electronics.

Encoders that use the absolute measuring method output **position values**. Some interfaces provide incremental signals as well.

Since absolute encoders do not require a reference run, they are ideal for use in concatenated manufacturing systems, transfer lines, and multi-axis machines. They are also highly immune to EMC disturbances.

Signal converters

Signal converters from HEIDENHAIN let you flexibly adapt your encoder signal interfaces to the requirements of your application. Depending on the application, additional signals (such as temperature-sensor signals) may be processed and transmitted to the downstream electronics.



Further information:

- www.heidenhain.com/products/signal-converters
- Brochure: *Cables and Connectors*

This brochure supersedes all previous editions, which thereby become invalid. The basis for ordering from HEIDENHAIN is always the brochure edition valid when the order is placed.

Standards (ISO, EN, etc.) apply only where explicitly stated in the brochure.

Contents

Serial data transmission				
Serial interfaces	EnDat	Bidirectional interface	With incremental signals	4
			Without incremental signals	
	Siemens	Proprietary interface	Without incremental signals	11
	Fanuc	Proprietary interface	Without incremental signals	
	Mitsubishi	Proprietary interface	Without incremental signals	
	Yaskawa	Proprietary interface	Without incremental signals	
	Panasonic	Proprietary interface	Without incremental signals	
	PROFIBUS DP	Fieldbus	Without incremental signals	12
	PROFINET IO	Ethernet-based fieldbus	Without incremental signals	14
	SSI	Synchronous serial interface	With incremental signals	16
Incremental signals				
Sinusoidal signals	1 V _{pp}	Voltage signals, highly interpolatable	18	
	11 μA _{pp}	Current signals, interpolatable	21	
Square-wave signals	TTL	RS-422, typically 5 V	22	
	HTL	Typically 10 V to 30 V	25	
	HTLs	Typically 10 V to 30 V, without inverted signals		
Other signals				
Commutation signals	Block commutation		27	
	Sinusoidal commutation		28	
Limit/homing	Limit switches		29	
	Position detection		30	
Further information				
Signal converters			32	
Testing and inspection devices, and diagnostics			34	
Measuring principles			38	
General electrical information			39	
Cable lengths			41	



EnDat 3 Proven and continuously developed interface technology

EnDat 3 carries forward the features and benefits of EnDat into the future of digital manufacturing. To achieve this feat, EnDat 3 relies on a new architecture that builds upon proven technology, ensuring optimal continuity and compatibility with predecessor interfaces.

EnDat 3 characteristics:

- Hybrid cable transmission
- Bus topologies
- Sensors: versatile data contents and sensor box
- Functional safety: black-channel communication
- Higher data bandwidth
- Definable send lists
- System installation: introduction of access levels

Ordering designations

The ordering designation defines key communication characteristics

 **Further information:**
www.endat.de

Interface	
Protocol	Request-response procedures in half-duplex mode
Physical layer	RS-485: 4-wire or 2-wire
Data rate	12.5 Mbit/s (25 Mbit/s)
Cable length	For 12.5 Mbit/s: max. 100 m / for 25 Mbit/s: max. 40 m
HPF send time (position availability in the master)	Typically 10 μ s (the parameter XEL.timeHPFout indicates the duration between position value generation (stored via latch) and transmission of the complete HPF, without cable effects)
Cycle time	Typically > 25 μ s
Bus operation	Daisy chain
Functional safety	Designed for up to SIL 3, black-channel communication

Functions	
Diagnostics	For condition monitoring and predictive maintenance
System information	Automated configuration and storage of operating status data
Access control	User authentication (e.g., for datum shift, OEM memory)

Supported communication types	E30-R2	E30-R4	E30-RB
EnDat 3: communication modulated onto power supply wires	✓	–	–
EnDat 3: communication + separate power supply wires (4 wires)	–	✓	✓
EnDat 3: bus operation	–	–	✓
Sensor box integration	–	✓	✓

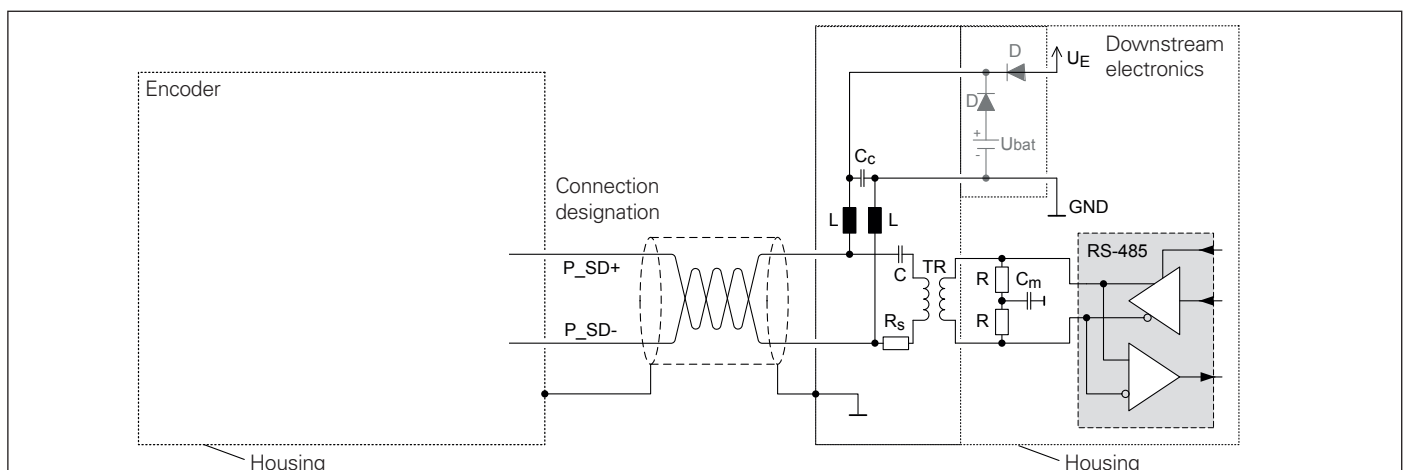

Block diagram: 2-wire

Communication

EnDat 3 requires two wires for communication. Two other wires are generally used with EnDat 3 for supplying power to the encoder. Thanks to the lack of a DC component, communication can be modulated onto the supply wires, thereby reducing the number of wires to a total of two for certain applications (e.g., hybrid motor cables). The EnDat 3 interface specification follows an OSI-based layer model.

The encoder-end of the interface is called the slave, and the downstream electronics the master. Communication occurs in half-duplex mode. A communication cycle consists of a request from the master followed by a response from the slave. Communication between the master and slave is subdivided into foreground communication and background communication.

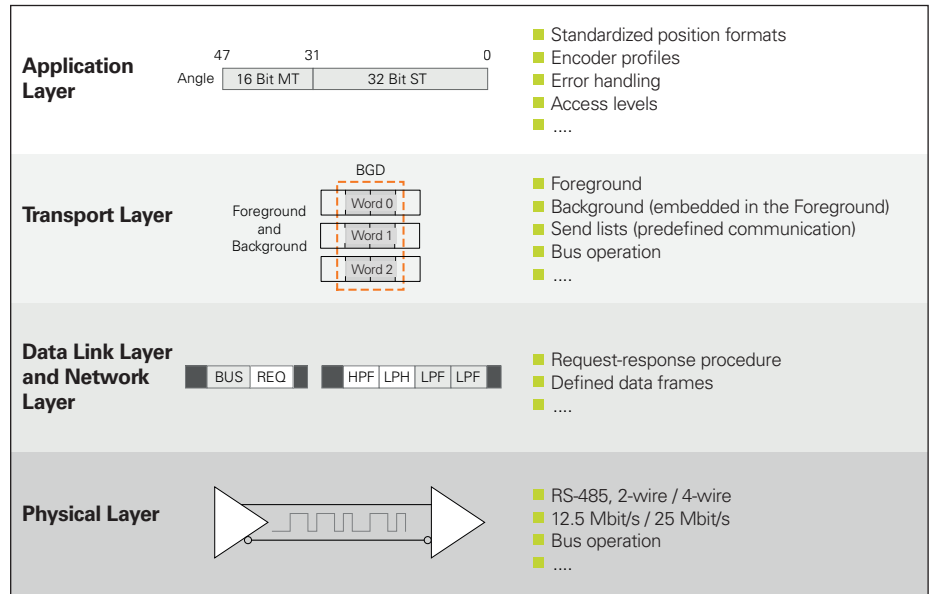

EnDat 3 communication layer model

Foreground communication

Foreground communication is for data that must be available in the communication cycle (e.g., controller cycle).

Requests and responses are organized into frames with a defined length. Each request and response begins with a preamble (PRE) and ends with a postamble (POST). The REQ request frame controls communication with the encoder or triggers certain actions within it (e.g., clearing of error messages), thereby also determining the contents of the response. Irrespective of the REQ frame contents, the response frame is chronologically divided into high-priority data and low-priority data.

A response contains the following elements:

- One HPF (High Priority Frame)
 - The HPF typically contains the encoder position. Depending on the encoder, other information can be specified for transmission in the HPF as well.
- One LPH (Low Priority Header)
 - The LPH carries status information about the subsequent data contents. It also contains information about the send list and the number of transmitted LPFs. The send list specifies the chronological sequence of LPFs within the individual communication cycles.
- Up to 15 optional LPFs (Low Priority Frames)
 - LPFs can carry additional data, such as diagnostic values, sensor information, or redundant information for functional safety.

The LPFs used in EnDat 3 build upon the concept of additional data found in EnDat 2.2. The switch between various LPFs is performed in accordance with a send list configured in the encoder's memory. The downstream electronics do not need to intervene in the controller cycle. The send list can be configured either in the encoder's volatile memory after each restart or permanently in its non-volatile memory. During operation, the send list specifies which LPFs are to be included in the response from cycle to cycle. Up to eight different send lists can be stored in the memory. The type of request determines which send list is active, thereby allowing the downstream electronics to respond with speed and flexibility to various operating statuses.

A sample communication cycle is shown below. A complete communication cycle always contains the white fields, as well as up to 15 optional LPFs (in gray). A CRC (Cyclic Redundancy Check) safeguards the REQ, HPF, and LPH protocol contents and each LPF.

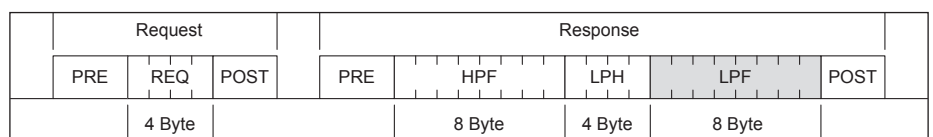

Communication cycle

Background communication

Some tasks, such as reading from and writing to the encoder memory, have low timing demands. For these kinds of tasks, EnDat 3 defines a background channel. Background communication is embedded in the foreground communication and uses its frames as transport carriers (REQ, LPH, LPF). The background channel thus makes it possible to read from and write to the encoder memory in the controller cycle. However, the background channel cannot handle real-time demands.

Bus operation

Along with point-to-point mode, EnDat 3 also offers bus operation for special applications. In bus operation, a Bus Request Frame is added in front of the Request Frame, thus allowing multiple participants to send responses in a single communication cycle.



Further information:

- EnDat 3 Interface Specification
- www.endat.de

Functional safety

EnDat supports the use of encoders in safety-related applications in accordance with the following standards: DIN EN ISO 13849-1 (successor to EN 954-1), as well as EN 61508 and EN 61800-5-2. In these standards, safety-related systems are assessed based on the failure probabilities of integrated components and subsystems, along with other criteria. This modular approach helps manufacturers implement their complete systems by allowing them to build upon previously qualified subsystems.

The functional safety provided with EnDat 3 encoders for applications up to SIL 3 is based on the following factors:

- Position value
 - Two independent position values: Pos1 (high resolution) and Pos2 (low resolution, if applicable)
 - Comparison of Pos1 and Pos2 by the safe control unit
- Forced dynamic sampling
 - Cyclic testing of the monitoring function in the encoder
- Error messages
 - Monitoring of error bits F1 and F2
- Due to the black channel, a safe EnDat master is not required and is thus not part of the safety chain
- Separation of communication to the motion controller and safe control unit (e.g., separate error messages)

In summary:

Convenient implementation is possible thanks to the black-channel approach combined with standardized position data formats and the option of moving forced dynamic sampling to the encoder.

Diagnostics

EnDat enables extensive encoder monitoring and diagnostics without an additional line. Its diagnostics generate valuation numbers, error messages, and warnings, and are a key ingredient in attaining high availability in the complete system.

The important factors:

- Machine utilization planning
- Support for the on-site service technician
- Easy evaluation of the encoder's function reserve
- Simplified troubleshooting for repairs
- Creation of informative quality statistics

For an analysis of encoder functionality, valuation numbers can be read cyclically from the encoder. Valuation numbers provide information about the current status of the encoder and its function reserve. Their identical scaling for all HEIDENHAIN encoders enables consistent analysis. The function reserves, combined with other sensor data, serve as the basis for condition monitoring and predictive maintenance in the higher-level downstream electronics.

System information

EnDat provides information about the encoder and the system in the form of an electronic ID label:

- Encoder parameters, which are all of the parameters needed for initial encoder configuration, are stored in the encoder.
- System parameters can be stored in the encoder's memory by the OEM or plant builder, and accessible areas can be password-protected.
- System or process status data, referred to as operating status data, can be stored in the encoder during normal operation; the encoder can even collect operating status data on its own.

Access control

Memory areas can be protected by various levels of user authentication. The available access levels are OEM1, OEM2, and User. Authentication is performed with a 32-bit password. As shipped, the encoder's OEM1, OEM2, and User areas are vacant and protectable by separate passwords.

Singleturn and multiturn information can also be separately configured and protected. Typical implementation:

- OEM1 (motor manufacturer): singleturn is set, and OEM1 memory is written to. A password is defined; the OEM1 area is protected.
- OEM2 (machine manufacturer): multiturn is set, and OEM2 memory is written to. A separate password is defined; the OEM2 area is protected.
- User (customer): the User memory can be written to. A separate password is defined; the User area is protected.



Further information:

- EnDat 3 Application Conditions for Functional Safety
- www.endat.de

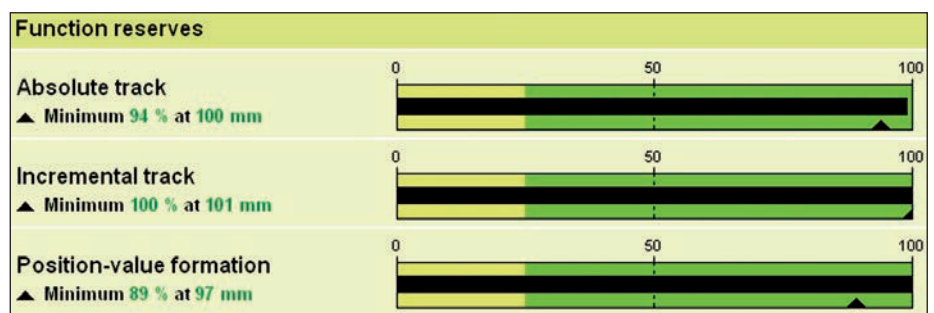

Sample display of the function reserve

Connection technology

Encoders with the purely serial EnDat interface predominantly use 8-pin M12 and 9-pin M23 connecting elements. This widespread connector technology offers the following benefits:

- Cost-effective connection technology
- Smaller connector dimensions and thinner connecting cables

Through its lower number of wires, EnDat 3 offers further options for miniaturizing the connection technology and adapting it to the application requirements.

Cables

High transmission frequencies over long cable lengths place rigorous technological demands on the cable. Specifically designed for this purpose, HEIDENHAIN cables are qualified to handle this type of application. We therefore recommend using HEIDENHAIN cables.

4-wire technology

In the 4-wire variant, the master powers the encoder with one wire pair and uses a second wire pair to communicate with the encoder.

2-wire technology (HMC 2)

Unlike the 4-wire option, the 2-wire variant requires additional hardware. In this configuration, the downstream electronics power and communicate with the encoder on the same wire pair. For this purpose, the encoder power supply and data stream are separated by frequency dividing networks (one on the master and one on the slave).

4-wire bus in daisy-chain mode

This variant allows encoders to be operated on a daisy-chain bus. Unlike the 4-wire variant, the 4-wire daisy-chain bus variant requires an additional transceiver branch inside the encoder. This additional transceiver branch establishes the data connection to the next encoder on the bus. The 4-wire daisy-chain bus variant also supports the 4-wire variant.

Sensor box

With the 4-wire variant, a sensor box can be inserted.

Power supply

The supply voltage and power consumption are stated in each encoder's specifications. For encoders with the EnDat 3 interface, a supply voltage of 12 V ($\pm 5\%$) is recommended.

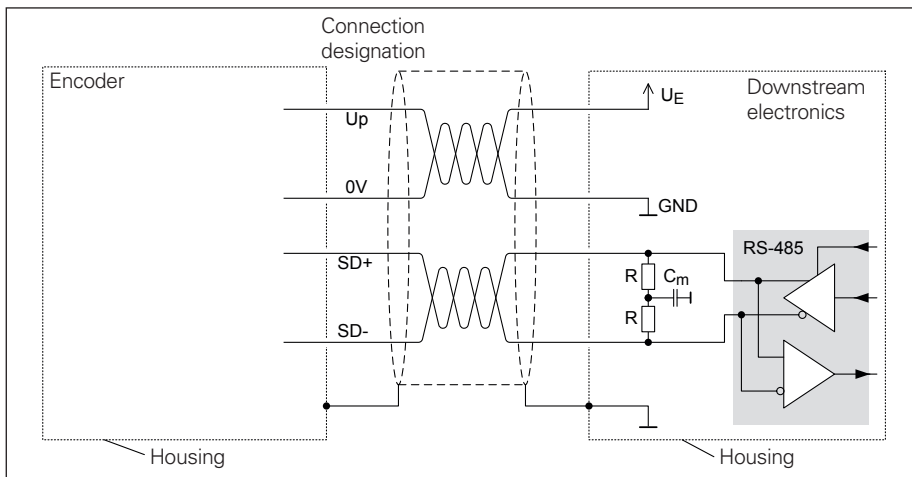

4-wire block diagram



HMC 2 single-cable solution: standard components for a reliable connection



Further information:

- EnDat 3 Hardware Specification
- Brochure: *Cables and Connectors*
- Product Information doc.: *HMC 6*
- Product Information doc.: *HMC 2*
- www.endat.de

EnDat 2.2 The bidirectional interface

The EnDat interface is a digital **bidirectional** interface for encoders. It can output **position values**, read and update information stored in the encoder, and store new information in the encoder. Thanks to the interface's **serial transmission method**, only **four signal lines** are required. The data are transmitted **synchronously** to the clock signal provided by the downstream electronics. The type of transmission (position values, parameters, diagnostics, etc.) is selected via mode commands sent to the encoder by the downstream electronics. Some functions are available only in conjunction with EnDat 2.2 mode commands.

History and compatibility

The EnDat 2.1 interface, which has been available since the mid-1990s, has since been upgraded to EnDat 2.2 (recommended for new applications). In terms of its communication, command sets, and time conditions, EnDat 2.2 is compatible with EnDat 2.1 but also offers significant advantages. For example, EnDat 2.2 permits the transfer of additional data (sensor values, diagnostic data, etc.), along with the position value, without initiating a separate request. This allows the interface to support additional types of encoders (e.g., encoders with buffer battery backup, incremental encoders). The interface protocol has also been expanded, and timing factors (clock frequency, calculation time, recovery time) have been optimized.

Supported encoder types

The following encoder types are currently supported with the EnDat 2.2 interface (readable from the memory area of the encoder):

- Incremental linear encoders
- Absolute linear encoders
- Incremental, singleturn rotational encoders
- Absolute, singleturn rotational encoders
- Multiturn rotary encoders
- Multiturn rotary encoders with buffer battery backup

For the various encoder types, some parameters must be interpreted differently (see the EnDat specifications), or EnDat additional data must be processed (e.g., incremental encoders or encoders with buffer battery backup).

Interface	EnDat serial bidirectional
Data transmitted	Position values, parameters, and additional data
Data input	Differential line receiver in compliance with EIA standard RS-485 for the CLOCK, $\overline{\text{CLOCK}}$, DATA, and $\overline{\text{DATA}}$ signals
Data output	Differential line driver in compliance with EIA standard RS-485 for the DATA and $\overline{\text{DATA}}$ signals
Position values	Ascending during movement in the direction of the arrow (see mating dimensions of the encoders)
Incremental signals	Depends on the encoder $\sim 1 V_{PP}$ TTL, HTL (see each type under <i>Incremental signals</i>)

Ordering designations

The ordering designations define the key specifications and provide the following information:

- Typical power supply range
- Command set
- Availability of incremental signals
- Maximum clock frequency

The second position in the ordering designation identifies the interface generation. For current-generation encoders, the ordering designation can be read from the encoder memory.

Incremental signals

Some encoders also provide incremental signals. These signals are primarily used for increasing the resolution of the position value or for providing data to a second downstream device. Current generations of encoders have a high internal resolution and therefore no longer need to provide incremental signals. The ordering designation indicates whether an encoder outputs incremental signals:

- EnDat01 With $1 V_{PP}$ incremental signals
- EnDatH With HTL incremental signals
- EnDatT With TTL incremental signals
- EnDat21 Without incremental signals
- EnDat02 With $1 V_{PP}$ incremental signals
- EnDat22 Without incremental signals

With regard to EnDat01/02:

The signal period is stored in the encoder memory

With regard to EnDatH/EnDatT:

The interpolation factor with which the internal incremental signals are output is indicated by a single letter added to the ordering designation:

- *a* 2-fold interpolation
- *b* Without interpolation
- *c* 0.5-fold interpolation (incremental signals/2)

Supply voltage

The typical supply voltage of the encoders depends on the interface:

EnDat01 EnDat21	5 V ± 0.25 V
EnDat02 EnDat22	3.6 V to 5.25 V or 14 V
EnDatH	10 V to 30 V
EnDatT	4.75 V to 30 V

Exceptions are documented in the specifications.

Command set

The command set describes the available mode commands, which define the information exchange between the encoder and the downstream electronics. The EnDat 2.2 command set includes all EnDat 2.1 mode commands. In addition, EnDat 2.2 permits further mode commands for the selection of additional data and enables memory accesses even in a closed control loop. When a mode command from the EnDat 2.2 command set is sent to an encoder that supports only the EnDat 2.1 command set, an error message is triggered. The supported command set is stored in the encoder's memory area:

- EnDat01/21/H/T Command set 2.1 or 2.2
- EnDat02/22 Command set 2.2

Clock frequency

The clock frequency is variable between 100 kHz and 2 MHz depending on the cable length (maximum: 150 m). With propagation-time compensation in the downstream electronics, clock frequencies of up to 16 MHz or cable lengths of up to 100 m are possible. In the case of EnDat encoders with the ordering designation EnDatx2, the maximum clock frequency is stored in the encoder memory. For all other encoders, the maximum clock frequency is 2 MHz. Propagation-time compensation is provided only for the ordering designations EnDat21 and EnDat22; for EnDat02, see the note below.

EnDat01 EnDatT EnDatH	≤ 2 MHz (see “without propagation-time compensation” in the diagram)
EnDat21	≤ 2 MHz
EnDat02	≤ 2 MHz or ≤ 8 MHz or 16 MHz (see note)
EnDat22	≤ 8 MHz or 16 MHz

In conjunction with long cable lengths, transmission frequencies of up to 16 MHz place high technological demands on the cable. For reasons concerning the transmission technology, the adapter cable connected directly to the encoder must not be longer than 20 m. Longer cable lengths can be realized with an adapter cable no longer than 6 m and an extension cable. As a rule, the entire transmission path must be designed for the given clock frequency.

Note on EnDat02

EnDat02 encoders may have a pluggable cable assembly. In choosing the version of the adapter cable, the customer decides whether the encoder will be operated with or without incremental signals. This also influences the maximum possible clock frequency. For adapter cables with incremental signals, the clock frequency is limited to 2 MHz; see also EnDat01. For adapter cables without incremental signals, the clock frequency can be up to 16 MHz. The exact values are stored in the encoder memory.

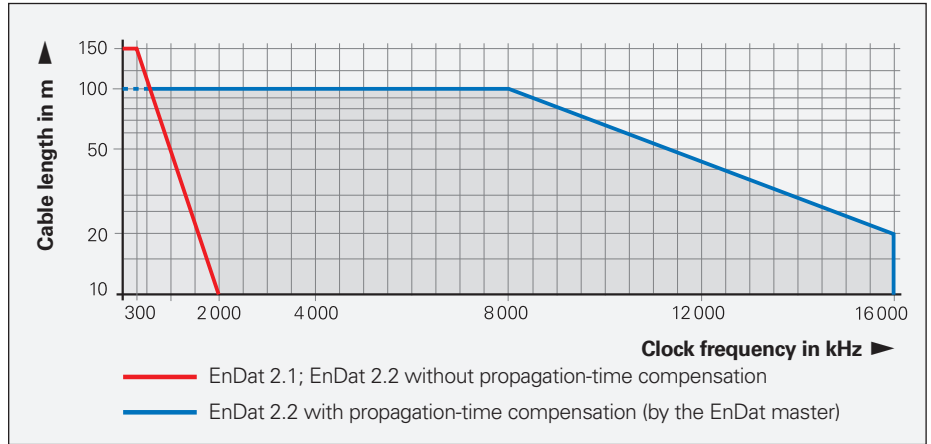

Under certain conditions, cable lengths of up to 300 m are possible after consultation with HEIDENHAIN

Position values

The position value can be transmitted with or without additional data. At the earliest, the position value is transmitted to the downstream electronics after the calculation time t_{cal} has elapsed, or after 14.5 clock pulses. The calculation time is determined for the encoder's highest permitted clock frequency, but for no more than 8 MHz.

For the position value, only the required number of bits is transferred. The number of bits thus depends on the given encoder and can be read from the encoder for automatic parameterization.

Typical operating modes

Operating mode EnDat 2.1: This mode is for encoders that provide additional incremental signals. For generation of the position value, the absolute position is read once simultaneously with the incremental position, and both are used in the calculation of the position value. The subsequent generation of the position value in the control loop is based on the incremental signals. Only EnDat 2.1 mode commands are used.

Operating mode EnDat 2.2: This mode is for purely serial encoders. For position value generation, the position value is read from the encoder during each control cycle. EnDat 2.2 mode commands are typically used to read the position value. EnDat 2.1 mode commands are typically used to read and write parameters after switch-on. In the closed control loop, the EnDat 2.2 interface allows additional data to be requested along with the position, and it permits the execution of functions (e.g., read/write parameters, reset error messages).

Additional data

Depending on the type of transmission (selection via MRS code), one or two items of additional data can be appended to the position value. The types of additional data supported by the respective encoder are saved in the encoder's parameters. Additional data encompasses the following:

Status information, addresses, and data

- WRN: warnings
- RM: reference mark
- Busy: parameter request

Additional data 1

- Diagnostics
- Position value 2
- Memory parameters
- MRS-code acknowledgment
- Test values
- Temperature
- Additional sensors

Additional data 2

- Commutation
- Acceleration
- Limit position signals
- Asynchronous position value
- Operating status error sources
- Timestamp

Memory areas

The encoder provides multiple memory areas for parameters. These memory areas can be read by the downstream electronics, and some areas can be written to by the encoder manufacturer, the OEM, or the end user. The parameter data are stored in permanent memory. This memory allows only a limited number of write accesses and is not designed for the cyclic storage of data. Certain storage areas can be write-protected (resettable only by the encoder manufacturer).

Parameters are stored in various memory areas, e.g.:

- Encoder-specific information
- Information from the OEM (e.g., electronic ID label of the motor)
- Operating parameters (datum shift, instruction, etc.)
- Operating status (alarms or warnings)

Monitoring and diagnostic functions

of the EnDat interface enable a detailed inspection of the encoder. These include the following:

- Error messages
- Warnings
- Online diagnostics based on valuation numbers for easily determining the function reserves of an encoder
- Parameters for mounting the encoder

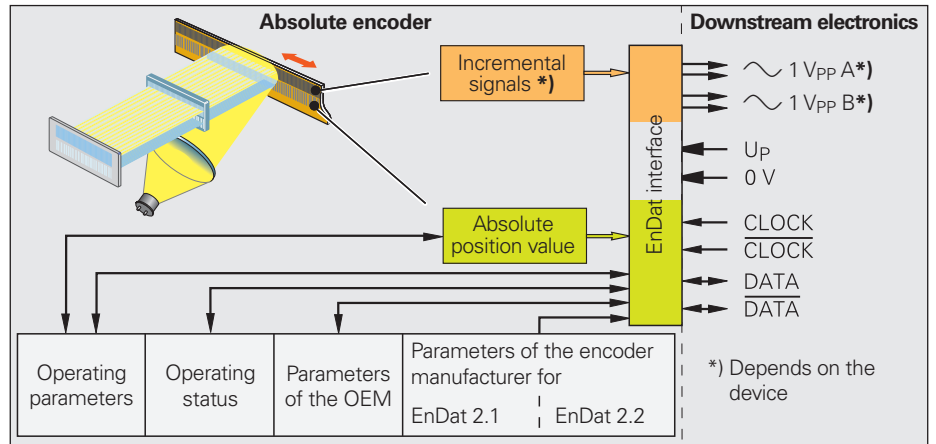

System information

EnDat provides information about the encoder and the system in the form of an electronic ID label:

- Encoder parameters, which are all of the parameters needed for initial encoder configuration, are stored in the encoder.
- System parameters can be stored in the encoder's memory by the OEM or plant builder.
- System or process status data, referred to as operating status data, can be stored in the encoder during closed loop operation.

Basics of functional safety

EnDat 2.2 strictly supports the use of encoders in safety-related applications. The basis for these are the standards DIN EN ISO 13849-1 (successor to EN 954-1), as well as EN 61508 and EN 61800-5-2. In these standards, safety-related systems are assessed based on criteria such as the failure probabilities of integrated components and subsystems. This modular approach helps manufacturers implement their complete systems by allowing them to build upon previously qualified subsystems.



Further information:

See *Functional Safety* at www.endat.de

Input circuit design of the downstream electronics

Dimensioning

IC₁ = RS-485 differential line receiver and driver

$$Z_0 = 120 \Omega$$

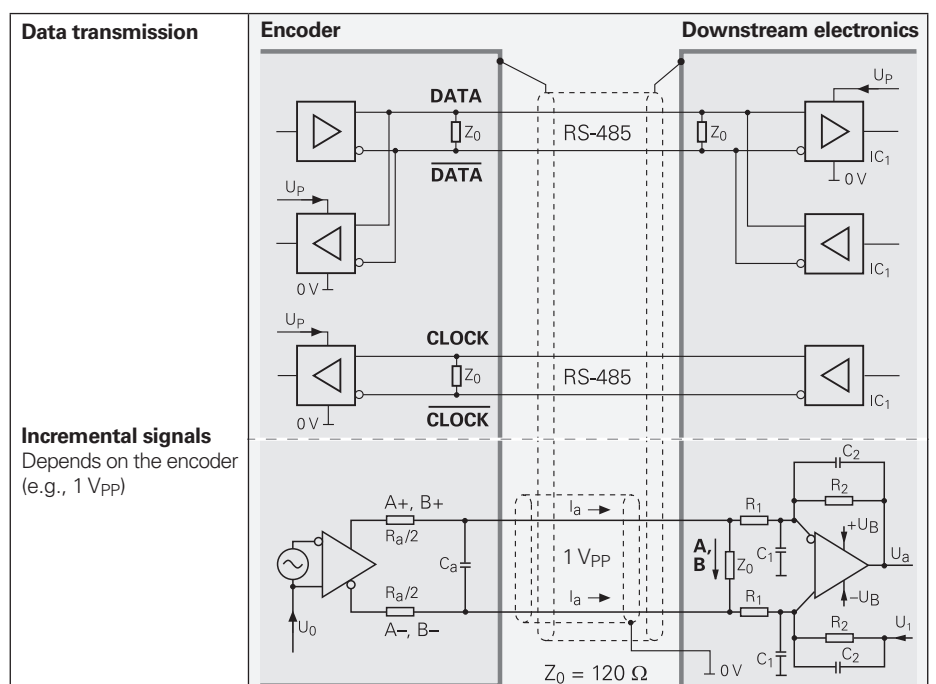

Further information:

FAQ: RS-485 transceiver at www.endat.de

Company-specific serial interfaces

Control manufacturer ¹⁾	Interface	Designation in brochure	Ordering designation	Code letter ²⁾	Comment
Siemens	Siemens DRIVE CLiQ	DRIVE-CLiQ	DQ01	S	
Fanuc	Fanuc Serial Interface α	Fanuc α	Fanuc02	F	Normal and high speed, two-pair transmission
	Fanuc Serial Interface α i	Fanuc α i	Fanuc05		High-speed, one-pair transmission includes the α interface (normal and high speed, two-pair transmission)
			Fanuc06		High-speed, one-pair transmission
Mitsubishi	Mitsubishi high speed interface	Mitsubishi	Mitsu01 Mit02-4 Mit02-2 Mit03-4 Mit03-2	M	Two-pair transmission Generation 1, two-pair transmission Generation 1, one-pair transmission Generation 2, two-pair transmission Generation 2, one-pair transmission
Yaskawa	Yaskawa serial interface	Yaskawa	YEC02	Y	–
			YEC07		Compatible with YEC02
Panasonic	Panasonic Serial Interface	Panasonic	Pana01	P	–
			Pana02		Compatible with Pana01

¹⁾ For more information on the combination of an encoder and control, please contact the control manufacturer

²⁾ The code letter is an add-on to the model designation of HEIDENHAIN encoders, such as in "LC 495S."

Position values

PROFIBUS DP serial interface



PROFIBUS DP

PROFIBUS is a non-proprietary, open fieldbus that conforms with the international standard EN 50170. Using fieldbus systems to connect sensors minimizes cabling and reduces the number of lines between the encoder and the downstream electronics.

Topology and bus assignment

PROFIBUS DP exhibits a linear structure permitting transfer rates up to 12 Mbit/s. Both mono-master and multi-master systems are possible. Each master can serve only its own slaves (polling). The slaves are polled cyclically by the master. Slaves can be sensors such as absolute rotary encoders and linear encoders, or they can also be control devices such as variable-frequency drives.

Physical-layer characteristics

The electrical characteristics of PROFIBUS DP comply with the RS-485 standard. The bus connection is a shielded, twisted-pair cable with active bus terminations at both ends.

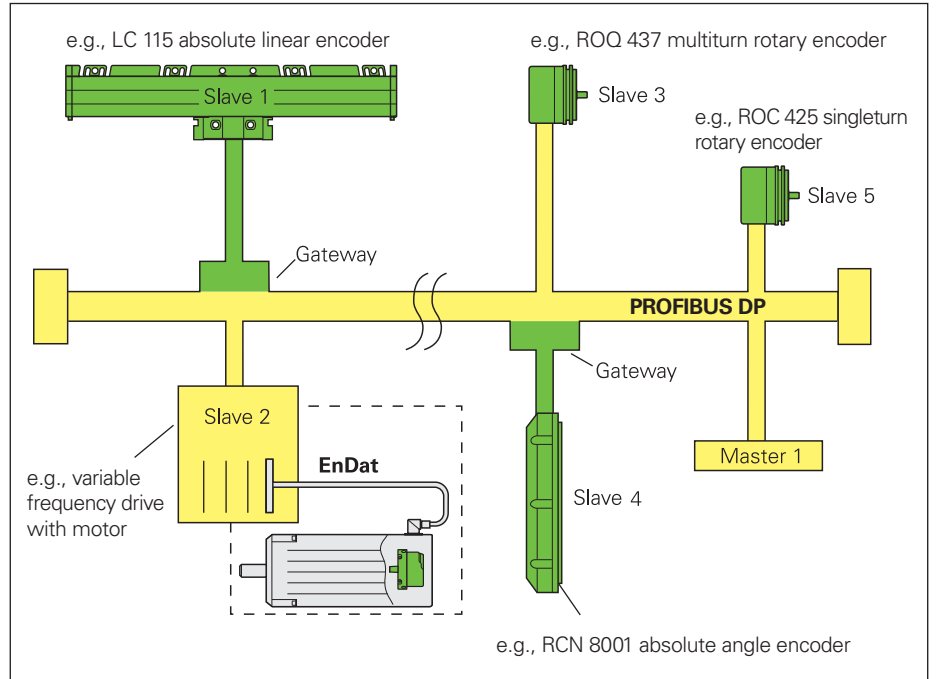

Bus structure of PROFIBUS DP

Initial setup

The data of the connectable HEIDENHAIN encoders required for system configuration are available for each encoder in the form of electronic device data sheets, commonly referred to as general station description files (GSD). These general station description files completely and unambiguously describe the characteristics of a device in a precisely defined format, thereby enabling the convenient and application-friendly integration of the devices into the bus system.

Configuration

PROFIBUS DP devices can be configured and the parameters assigned to fit the requirements of the user. These settings are saved in the master once they have been selected in the configuration tool with the help of the GSD file. As a result, PROFIBUS devices are configured during every network start-up. This simplifies device replacement by eliminating the need for editing or re-entry of the configuration data.

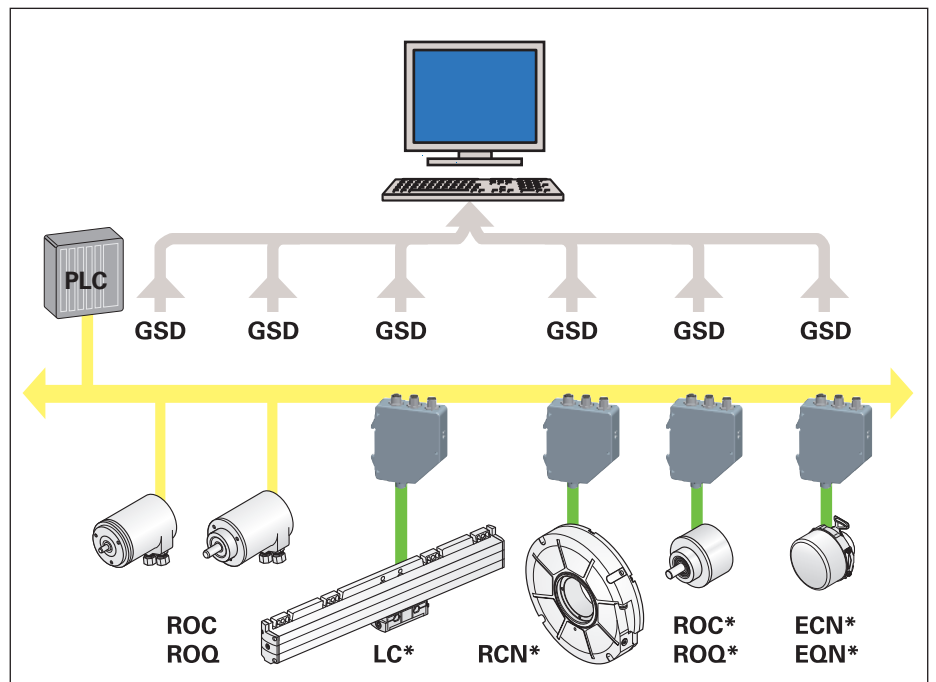

* With the EnDat interface

There are two GSD files to choose from:

- GSD file for the DP-V0 profile
- GSD file for the DP-V1 and DP-V2 profiles

PROFIBUS DP profile

The PNO (PROFIBUS user organization) has defined standard, non-proprietary profiles for the connection of absolute encoders to PROFIBUS DP. High flexibility and simple configuration are thereby ensured for all equipment using these standardized profiles.

DP-V0 profile

This profile can be requested from the PNO in Karlsruhe, Germany (ordering number: 3.062). There are two classes defined in this profile: Class 1 is equivalent to the minimum range of functions, and Class 2 contains additional functions, some of which are optional.

DP-V1 and DP-V2 profiles

The profiles can be requested from the PNO in Karlsruhe, Germany (ordering number: 3.162). These profiles likewise distinguish between two device classes:

- Class 3, with the basic functions, and
- Class 4, with the full scaling and preset functionality.

In addition to the mandatory functions of classes 3 and 4, optional functions are defined as well.

Supported functions

Of particular importance in decentralized fieldbus systems are **diagnostic functions** (e.g., warnings and alarms) and the **electronic ID label**, which contains information about the encoder model, resolution, and measuring range. Also possible are programming functions, such as reversal of counting direction, **preset/datum shift**, and **changing the resolution (scaling)**. The **operating time** and the speed of the encoder can also be recorded.

Encoders with PROFIBUS DP

Absolute encoders with an **integrated PROFIBUS DP interface** are connected directly to the PROFIBUS fieldbus. The rear side of these encoders is equipped with LEDs for indicating the **operating status**, supply voltage, and bus status.

The coding switches for addressing (0 to 99) and for activating the terminating resistor are easily accessible under the bus cover. The terminating resistor must be activated if the rotary encoder is the final participant on the PROFIBUS DP fieldbus and if the external terminating resistor is not in use.

Functions of the DP-V0 classes

Characteristic <i>Data word width</i>	Class	Rotational encoders		Linear encoders
		≤ 16 bits	≤ 31 bits ¹⁾	≤ 31 bits ¹⁾
Pos. value in pure binary code	1, 2	✓	✓	✓
Data word length	1, 2	16	32	32
Scaling function				
Measuring steps/rev.	2	✓	✓	–
Total resolution	2	✓	✓	–
Reversal of counting direction	1, 2	✓	✓	–
Preset (output data: 16 bits or 32 bits)	2	✓	✓	✓
Diagnostic functions				
Warnings and alarms	2	✓	✓	✓
Operating time recording	2	✓	✓	✓
Speed	2	✓ ²⁾	✓ ²⁾	–
Profile version	2	✓	✓	✓
Serial number	2	✓	✓	✓

¹⁾ With a data word width > 31 bits, only the upper 31 bits are transferred

²⁾ Requires a 32-bit configuration of the output data and a 32 + 16-bit configuration of the input data

Functions of the DP-V1 and DP-V2 classes

Characteristic <i>Data word width</i>	Class	Rotational encoders		Linear encoders
		≤ 32 bits	> 32 bits	
Telegram	3, 4	81-84	84	81-84
Scaling function	4	✓	✓	–
Reversal of counting direction	4	✓	✓	–
Preset / datum shift	4	✓	✓	✓
Acyclic parameters	3, 4	✓	✓	✓
Channel-dependent diagnosis via alarm channel	3, 4	✓	✓	✓
Operating time recording	3, 4	✓ ¹⁾	✓ ¹⁾	✓ ¹⁾
Speed	3, 4	✓ ¹⁾	✓ ¹⁾	–
Profile version	3, 4	✓	✓	✓
Serial number	3, 4	✓	✓	✓

¹⁾ Not supported by DP-V2

PROFINET IO serial interface



PROFINET IO

PROFINET IO is the open Industrial Ethernet standard for industrial communication. It builds on the field-proven functional model of PROFIBUS DP but uses fast Ethernet technology as its physical transmission medium, making it well adapted to the fast transmission of I/O data. This standard also provides the option of transmitting demand data, parameters, and IT functions.

PROFINET enables the connection of decentralized field devices to a controller. It also describes parameterization, diagnostics, and the exchange of data between the controller and field devices. The PROFINET design is modular. Cascading functions can be selected by the user himself. In order for the high speed requirements to be met, these functions primarily differ in terms of their data exchange type.

Topology and bus assignment

A PROFINET IO system consists of:

- **IO controller** (control/PLC; controls the automation task)
- **IO device** (decentralized field device such as a rotary encoder)
- **IO supervisor** (development or diagnostic tool such as a PC or programming device)

PROFINET IO follows the provider-consumer model, which supports communication between Ethernet peers. One advantage is that the provider transmits its data without any prompting by the communication partner.

Physical-layer characteristics

HEIDENHAIN encoders are connected to PROFINET in accordance with 100BASE-TX (IEEE 802.3, Clause 25) over one shielded, twisted wire pair in each direction. The data transfer rate is 100 Mbit/s (fast Ethernet).

PROFINET profile

HEIDENHAIN encoders generally satisfy the definitions as per Profile 3.162, Version 4.2. This device profile describes the functionality of the rotary encoder. Class 4 functions are supported (full scaling and preset functionality). More information about PROFINET can be obtained from the PROFIBUS user organization (PNO).

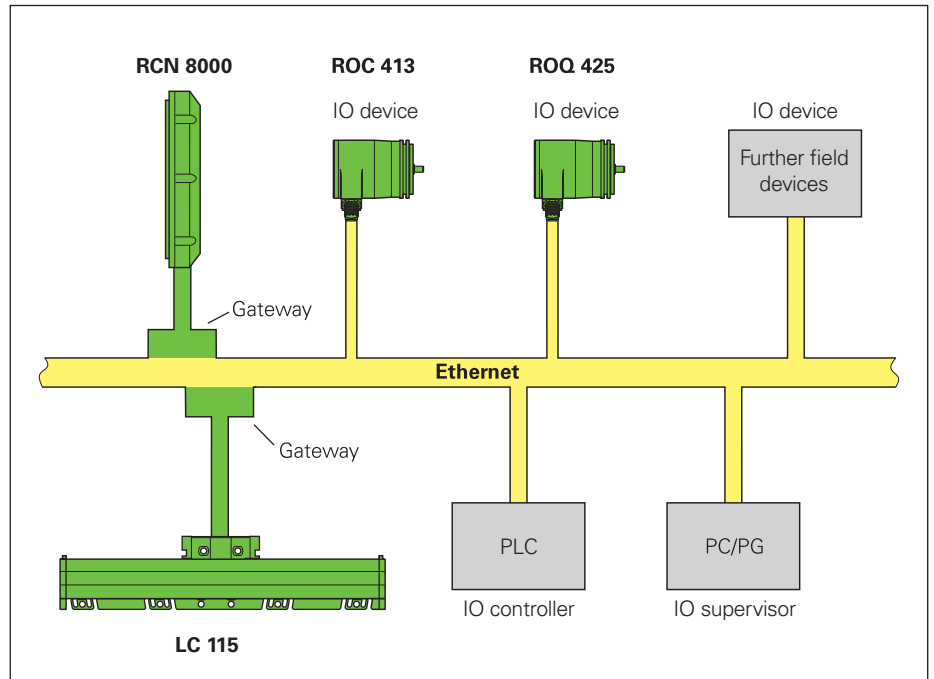

Supported functions	Class	Rotary encoders		Linear encoders
		Singletum	Multitum	
Position value	3, 4	✓	✓	✓
Isochronous mode	4	✓	✓	✓
Functions of Class 4	4	✓	✓	✓
Scaling function	4	✓	✓	–
Measuring units per revolution	4	✓	✓	–
Total measuring range	4	✓	✓	–
Cyclic operation (binary scaling)	4	✓	✓	–
Acyclic operation	4	✓	✓	–
Preset	4	✓	✓	✓
Code sequence	4	✓	✓	✓
Preset control G1_XIST1	4	✓	✓	✓
Compatibility mode (encoder profile V.3.1)	3, 4	✓	✓	✓
Operating time	3, 4	✓	✓	✓
Speed	3, 4	✓	✓	✓
Profile version	3, 4	✓	✓	✓
Permanent storage of the offset value	4	✓	✓	✓
Identification & maintenance (I & M)		✓	✓	✓
External firmware upgrade		✓	✓	✓

Initial setup

In order for an encoder with the PROFINET interface to be put into operation, a general station description (GSD) file must be downloaded and imported into the configuration software. The GSD file contains the execution parameters required for a PROFINET IO device.

Configuration

Profiles are predefined configurations of the functions and performance characteristics available from PROFINET for use in certain devices or applications, such as in rotary encoders. They are defined and published by the workgroups of PROFIBUS & PROFINET International (PI).

Profiles are important for openness, interoperability, and exchangeability, assuring the end user that similar devices from different manufacturers operate in a standardized manner.

Encoders or gateway with PROFINET

The encoders with integrated PROFINET interface or the gateway are incorporated directly into the network. Addresses are automatically assigned via a protocol integrated into PROFINET. A PROFINET IO field device is addressed within a network via its physical device MAC address. The encoders feature two dual-color LEDs for bus and device diagnostics.

A terminating resistor for the final participant is not needed.

SSI serial interface

Starting with the Most Significant Bit (MSB), the absolute **position value** is transmitted over the data lines (DATA) at a clock speed provided by the control (CLOCK). The SSI-standard data word length for singleturn encoders is 13 bits, and for multiturn encoders, 25 bits. In addition to the absolute position values, **incremental signals** can be transmitted. For a signal description, see *Incremental signals*.

The following **functions** can be activated via the programming inputs of the interface through application of the supply voltage U_P :

- **Direction of rotation**

The continuous application of a HIGH level on PIN 2 ($t_{\min} > 1$ ms) reverses the direction of rotation for ascending position values.

- **Zeroing** (setting to zero)

Application of a positive edge ($t_{\min} > 12$ ms) to PIN 5 sets the current position value to zero (encoder must be at a standstill).

Warning: The programming inputs must always be terminated with a resistor (see *Input circuit design of the downstream electronics*).

Interface	SSI serial
Ordering designation	<i>Singleturn:</i> SSI 39r1 <i>Multiturn:</i> SSI 41r1
Data transmitted	Absolute position values
Data input	Differential line receiver in compliance with EIA standard RS-485 for CLOCK and $\overline{\text{CLOCK}}$ signals
Data output	Differential line driver in compliance with EIA standard RS-485 for DATA and $\overline{\text{DATA}}$ signals
Code	Gray code
Ascending position values	With clockwise rotation as viewed from the flange side (switchable via interface)
Incremental signals	Depends on the encoder $\sim 1 V_{PP}$, TTL, HTL (see each type under <i>Incremental signals</i>)
Programming inputs Inactive Active	Direction of rotation and zeroing; for availability, see encoder documentation LOW $< 0.25 \cdot U_P$ HIGH $> 0.6 \cdot U_P$
Connecting cable Cable length Signal propagation time	HEIDENHAIN shielded cables; e.g., PUR [(4 x 0.14 mm ²) + 4(2 x 0.14 mm ²) + (4 x 0.5 mm ²)] Max. 100 m 6 ns/m

Control cycle for a complete data format

When not transmitting, the clock and data lines are held at HIGH level. The internally and cyclically generated position value is stored on the first falling clock edge. The data are transmitted on the first rising clock edge.

After transmission of a complete data word, the data output line remains at LOW level until the encoder is ready for a new measured-value request (t_2). Encoders with the SSI 39r1 or SSI 41r1 interfaces additionally require a subsequent clock pause (t_R). If another data-output request (CLOCK) is received within this time (t_2 or t_2+t_R), then the same data will be output again.

If the data output is interrupted (CLOCK = HIGH for $t \geq t_2$), then a new position value will be stored on the next falling clock edge. The downstream electronics read the data at the next rising clock edge.

Data transmission

$T = 1 \mu\text{s}$ to $10 \mu\text{s}$
 t_{cal} See the specifications
 $t_1 \leq 0.4 \mu\text{s}$ (without cable)
 $t_2 = 17 \mu\text{s}$ to $20 \mu\text{s}$
 $t_R \geq 5 \mu\text{s}$
 n = Data word length
 13 bits for ECN/ROC
 25 bits for EQN/ROQ

CLOCK and DATA not shown

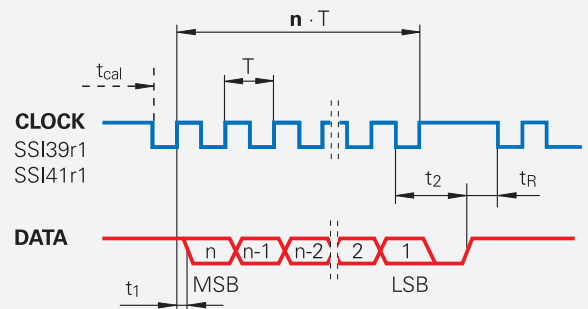

Permissible clock frequency as a function of cable length

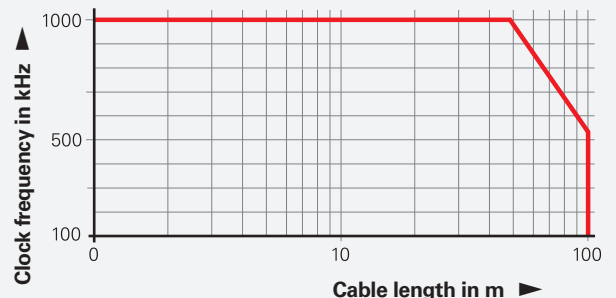

Incremental signals

Some encoders also provide incremental signals. These signals are primarily used for increasing the resolution of the position value or for providing data to a second downstream device. They are almost always $1 V_{PP}$ incremental signals. Exceptions are identifiable based on the ordering designation:

- SSI41H With HTL incremental signals
- SSI41T With TTL incremental signals

Input circuit design of the downstream electronics

Dimensioning

IC_1 = Differential line receiver and driver
 e.g., SN 65 LBC 176
 LT 485

$Z_0 = 120 \Omega$

$C_3 = 330 \text{ pF}$ (for improved noise immunity)

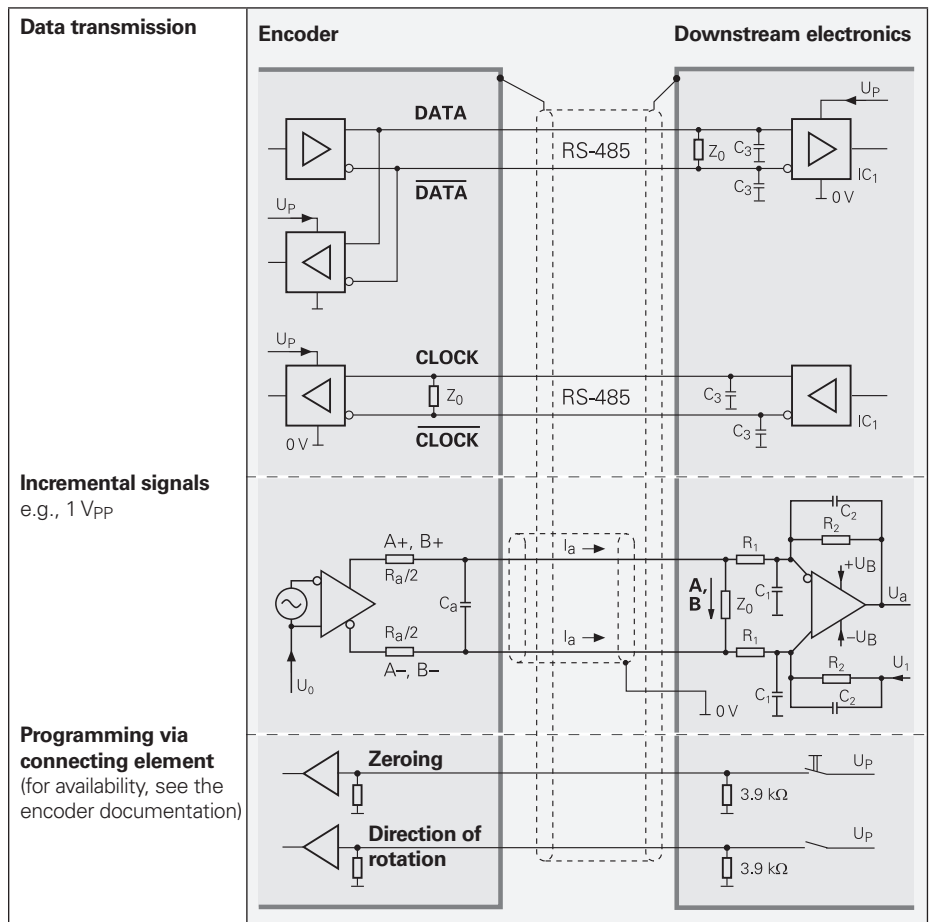

Incremental signals

~ 1 V_{PP} sinusoidal signals

HEIDENHAIN encoders with ~ 1 V_{PP} interface provide voltage signals that can be highly interpolated.

The sinusoidal **incremental signals** A and B are phase-shifted by 90° elec. and have amplitudes of typically 1 V_{PP}. The illustrated sequence of output signals, with B lagging A, applies to the direction of motion shown in the dimension drawing.

The **reference mark signal** R has a usable component G of approx. 0.5 V. Next to the reference mark, the output signal can be reduced by up to 1.7 V to a quiescent value H. The downstream electronics must not be allowed to overdrive on account of this. Even at the low quiescent level, signal peaks with amplitude G can appear.

The **signal amplitude** is valid when the supply voltage stated in the specifications is applied at the encoder. The signal amplitude is based on a differential measurement between the associated outputs at the 120 ohm terminating resistor. The signal amplitude decreases when the frequency increases. The **cutoff frequency** is the frequency up to which a certain percentage of the original signal amplitude is maintained:

- -3 dB ≙ 70% of the signal amplitude
- -6 dB ≙ 50% of the signal amplitude

The parameters in the signal description apply to motion at up to 20% of the -3 dB cutoff frequency.

Interpolation/resolution/measuring step

The output signals of the 1 V_{PP} interface are usually interpolated in the downstream electronics in order to attain sufficiently high resolutions. For **speed control**, interpolation factors of greater than 1000 are normally used in order to provide usable data even at low shaft speeds or traversing speeds.

Measuring steps for **position measurement** are recommended in the specifications. Other resolutions are also possible for special applications.

Interface	~ 1 V _{PP} sinusoidal voltage signals
Incremental signals	Two nearly sinusoidal signals A and B Signal amplitude M: 0.6 to 1.2 V _{PP} ; typ. 1 V _{PP} Asymmetry P - N /2M: ≤ 0.065 (equivalent to 15°) Amplitude ratio M _A /M _B : 0.8 to 1.25 Phase angle φ ₁ + φ ₂ /2: 90° ± 10° elec.
Reference mark signal	One or more signal peaks R Usable component G: ≥ 0.2 V Quiescent value H: ≤ 1.7 V Signal-to-noise ratio E, F: 0.04 V to 0.68 V Zero crossovers K, L: 180° ± 90° elec.
Connecting cable	HEIDENHAIN shielded cables; e.g., PUR [4(2 × 0.14 mm ²) + (4 × 0.5 mm ²)]
Cable length	Max. 150 m
Signal propagation time	6 ns/m

These values can be used for the dimensioning of the downstream electronics. Encoder tolerances that are subject to constraints are listed in the specifications. For encoders without an integral bearing, reduced tolerances are recommended for initial setup (see mounting instructions).

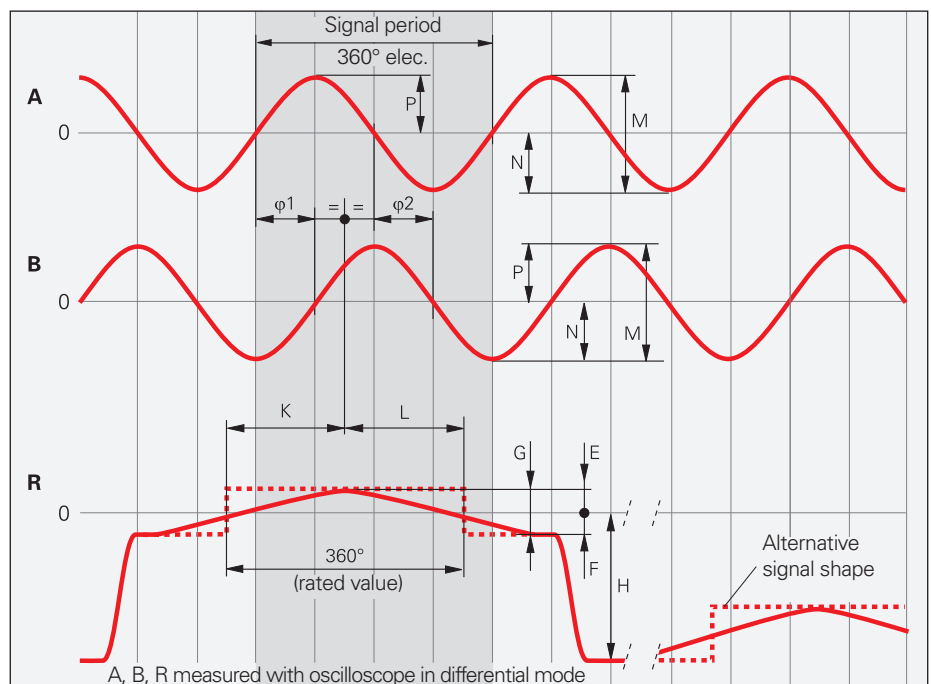

Short-circuit stability

The shorting of outputs is not a permissible operating condition. Excepted from this are encoders with a supply voltage of DC 5 V $\pm 5\%$, which do not fail if an output briefly shorts to 0 V or U_P

Short circuit at	20 °C	125 °C
One output	< 3 min	< 1 min
All outputs	< 20 s	< 5 s

Cutoff frequency

Typical signal amplitude curve as a function of the output frequency (may vary depending on the encoder)

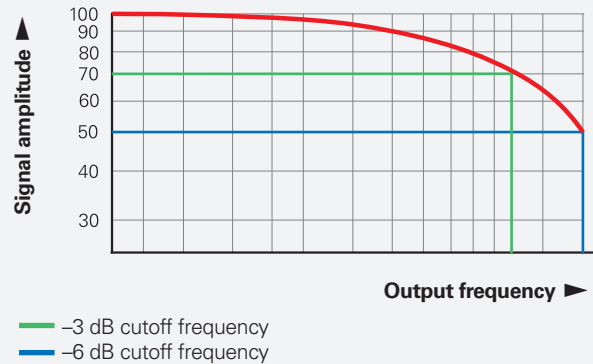

Monitoring of the incremental signals

The following sensitivity levels are recommended for monitoring the signal amplitude M :

Lower threshold: 0.30 V_{PP}
Upper threshold: 1.35 V_{PP}

The amplitude of the incremental signals can be monitored based on the length of the position indicator arrow: the A and B output signals are shown as a Lissajous figure in the XY representation of the oscilloscope. Ideal sinusoidal signals produce a circle with a diameter M . In this case, the position indicator r (shown) is equivalent to $\frac{1}{2}M$. The following formula applies:

$$r = \sqrt{A^2 + B^2}$$

Where: $0.3V < 2r < 1.35V$

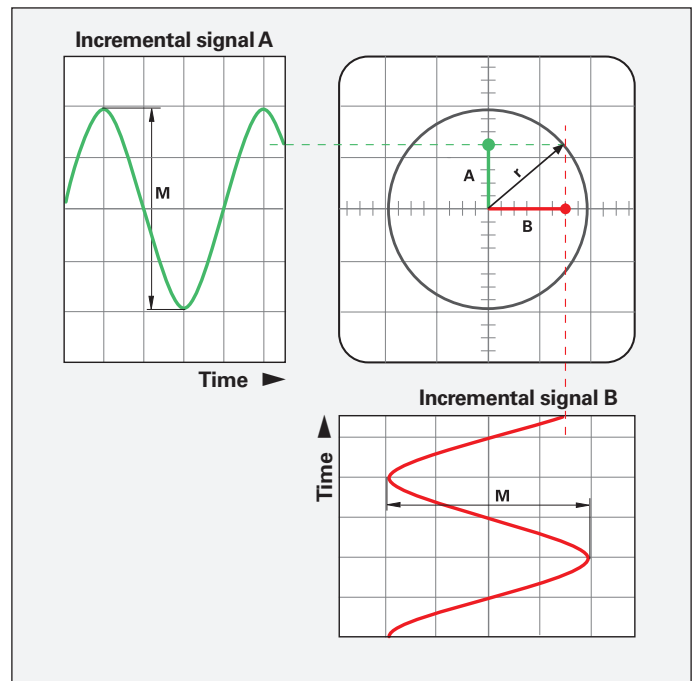

Input circuit design of the downstream electronics

Dimensioning

Operational amplifier (e.g., MC 34074)

$Z_0 = 120 \Omega$

$R_1 = 10 \text{ k}\Omega$ and $C_1 = 100 \text{ pF}$

$R_2 = 34.8 \text{ k}\Omega$ and $C_2 = 10 \text{ pF}$

$U_B = \pm 15V$

$U_1 \approx U_0$

-3 dB cutoff frequency of the circuit

$\approx 450 \text{ kHz}$

$\approx 50 \text{ kHz}$ with $C_1 = 1000 \text{ pF}$
and $C_2 = 82 \text{ pF}$

The circuit variant for 50 kHz does reduce the bandwidth of the circuit but also improves its immunity to interference.

Incremental signals Reference mark signal

$R_a < 100 \Omega$, typ. 24 Ω

$C_a < 50 \text{ pF}$

$\Sigma I_a < 1 \text{ mA}$

$U_0 = 2.5V \pm 0.5V$
(referenced to 0V of the power supply)

Encoder

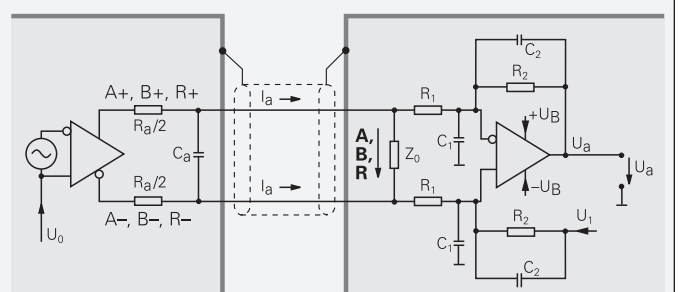

Output signals of the circuit

$U_a = \text{typ. } 3.48 V_{PP}$

Gain: 3.48-fold

Input circuit design of the downstream electronics for high signal frequencies

For high-accuracy encoders with a high signal frequency, a special input circuit is necessary.

-3 dB cutoff frequency of the circuit

Various circuit variants are possible for the input circuit, thereby allowing various cutoff frequencies to be implemented. Depending on the application and the encoder being used, the receiver circuit may need to be adapted in order to achieve maximum performance from the overall system.

Output signals of the circuit

The input circuit has been optimized for a downstream A/D converter with an input range of $2 V_{PP}$. This yields a signal gain factor of 1.21, resulting in an output voltage $U_a = 1.21 V_{PP}$ for the A and B signals. The signal gain factor for the R signal is 0.58.

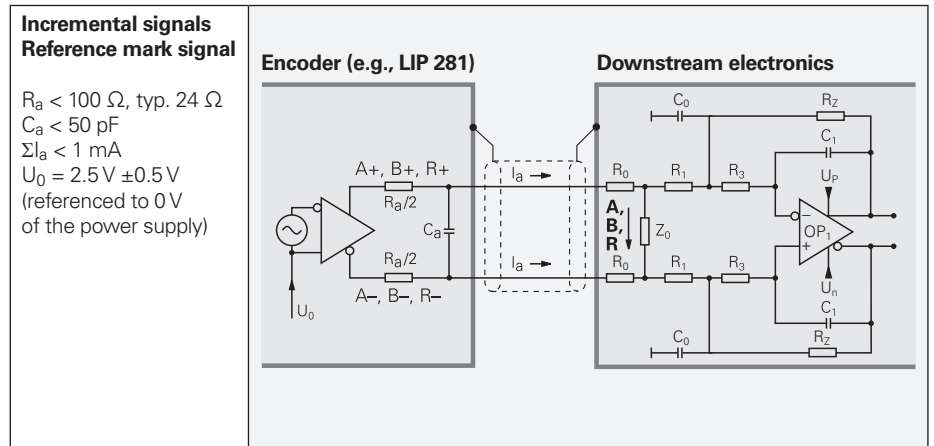

	Cutoff frequency -3 dB							
	500 kHz		2.5 MHz		5 MHz		10 MHz	
Signal	A, B	R	A, B	R	A, B	R	A, B	R
U_a	0 V		0 V		0 V		0 V	
U_p	+5 V		+5 V		+5 V		+5 V	
U_n	0 V		0 V		0 V		0 V or -5 V	
Z_0^*	127 Ω	59.0 Ω	133 Ω	59.0 Ω	133 Ω	59.0 Ω	133 Ω	59.0 Ω
R_0	0 Ω	31.6 Ω	0 Ω	31.6 Ω	0 Ω	31.6 Ω	0 Ω	31.6 Ω
R_1	1.21 k Ω		681 Ω		681 Ω		681 Ω	
R_2	1.47 k Ω		825 Ω		825 Ω		825 Ω	
R_3	1.82 k Ω		464 Ω		464 Ω		464 Ω	
C_0	220 pF		100 pF		47 pF		22 pF	
C_1	68 pF		47 pF		22 pF		10 pF	
OP_1	e.g., THS452x						e.g., AD8138	

* The resulting effective terminating resistance of the circuit is $\approx 120 \Omega$ for A, B, and R.

~ 11 μ A_{PP} sinusoidal signals

HEIDENHAIN encoders with ~ 11 μ A_{PP} interface provide current signals. These encoders are intended for connection to ND digital readouts or EXE signal converters from HEIDENHAIN.

The sinusoidal **incremental signals** I_1 and I_2 are phase-shifted by 90° elec. and have signal levels of typically 11 μ A_{PP}. The illustrated sequence of output signals—with I_2 lagging I_1 —applies to the direction of motion indicated in the dimension drawing (or to plunger retraction in the case of length gauges).

The **reference mark signal** I_0 has a usable component G of approx. 5.5 μ A.

The **signal amplitude** is valid when the supply voltage stated in the specifications is applied at the encoder. It is based on a differential measurement between the associated outputs. The signal amplitude decreases when the frequency increases. The **cutoff frequency** is the frequency up to which a certain percentage of the original signal amplitude is maintained:

- -3 dB cutoff frequency: 70% of the signal amplitude
- -6 dB cutoff frequency: 50% of the signal amplitude

Interpolation/resolution/measuring step

The output signals of the 11 μ A_{PP} interface are usually interpolated in the downstream electronics (ND digital readouts or EXE signal converters from HEIDENHAIN) in order to attain sufficiently high resolutions.

Interface	~ 11 μ A _{PP} sinusoidal current signals
Incremental signals	Two approximately sinusoidal signals I_1 and I_2 Signal amplitude M: 7 to 16 μ A _{PP} ; typ. 11 μ A _{PP} Asymmetry $ P - N /2M$: ≤ 0.065 (equivalent to 15°) Amplitude ratio M_A/M_B : 0.8 to 1.25 Phase angle $ \varphi_1 + \varphi_2 /2$: $90^\circ \pm 10^\circ$ elec.
Reference mark signal	One or more signal peaks I_0 Usable component G: 2 μ A to 8.5 μ A Signal-to-noise ratio E, F: ≥ 0.4 μ A Zero crossovers K, L: $180^\circ \pm 90^\circ$ elec.
Connecting cable	HEIDENHAIN shielded cable PUR $[3(2 \times 0.14 \text{ mm}^2) + (2 \times 1 \text{ mm}^2)]$
Cable length	Max. 30 m
Signal propagation time	6 ns/m

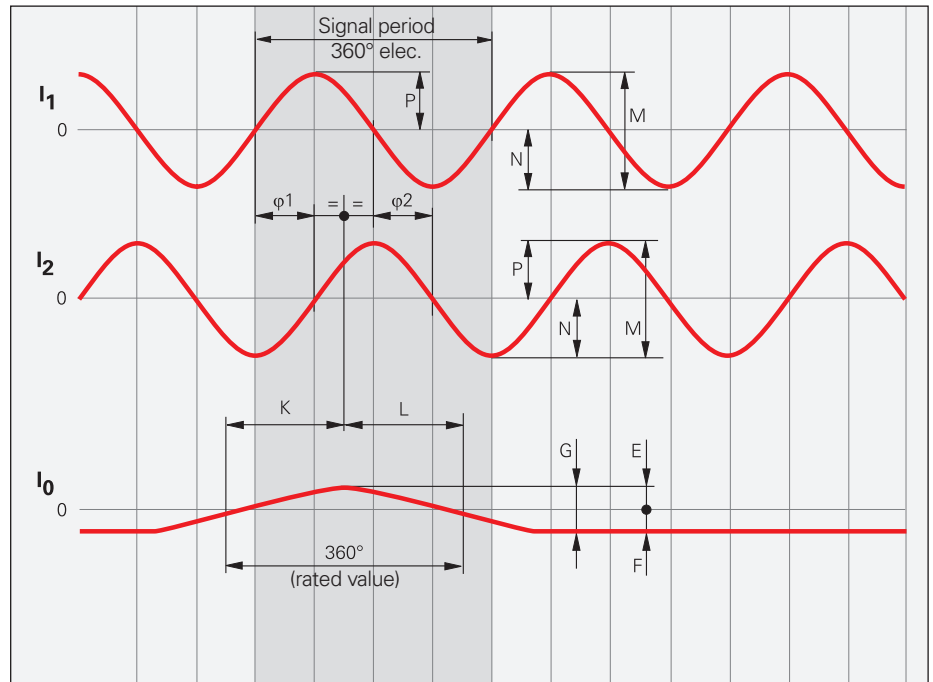

□TTL square-wave signals

HEIDENHAIN encoders with the □TTL interface contain electronics that digitize sinusoidal scanning signals either with or without interpolation.

The **incremental signals** are transmitted as the square-wave pulse trains U_{a1} and U_{a2} , phase-shifted by 90° elec. The **reference mark signal** consists of one or more reference pulses U_{a0} , which are gated with the incremental signals. In addition, the integrated electronics produce their **inverted signals** $\overline{U_{a1}}$, $\overline{U_{a2}}$, and $\overline{U_{a0}}$ for noise-proof transmission. The illustrated sequence of output signals—with U_{a2} lagging U_{a1} —applies to the direction of motion shown in the dimension drawing.

The **fault-detection signal** $\overline{U_{aS}}$ indicates malfunctions such as breakage of the power lines or failure of the light source. In automated manufacturing, for example, it can be used for machine switch-off.

The distance between two successive edges of the incremental signals U_{a1} and U_{a2} through 1-fold, 2-fold, or 4-fold evaluation is one **measuring step**.

The downstream electronics must be designed to detect each edge of the square-wave pulse. The minimum **edge separation a** stated in the specifications is valid for the input circuit shown, in conjunction with a cable length of 1 m, and is based on a measurement at the output of the differential line receiver. For the evaluation of the reference mark signal, the level of the reference mark signal is usually checked when signals U_{a1} and U_{a2} are at HIGH level and are gated with the edge change at U_{a1} or U_{a2} .

Note:

Not all encoders output a reference-mark signal, fault-detection signal, and inverted signals. Please see the pin layout for this.

Interface	□TTL square-wave signals	
Incremental signals	Two TTL square-wave signals U_{a1} , U_{a2} and their inverted signals $\overline{U_{a1}}$, $\overline{U_{a2}}$	
Reference mark signal Pulse width Delay time	One or more TTL square-wave pulses U_{a0} and their inverse pulses $\overline{U_{a0}}$ 90° elec. (other widths upon request) $ t_d \leq 50$ ns	
Fault-detection signal Pulse width	One TTL square-wave pulse $\overline{U_{aS}}$ Fault detection: LOW (upon request: high-impedance U_{a1}/U_{a2}) Proper functioning: HIGH $t_s \geq 20$ ms	
Signal amplitude	Differential line driver as per EIA standard RS-422	
Permissible load	$Z_0 \geq 100 \Omega$ Between associated outputs $ I_L \leq 20$ mA Max. load per output $C_{load} \leq 1000$ pF To 0 V Outputs are protected against a short to 0 V	
Switching times (10% to 90%)	$t_+/t_- \leq 30$ ns (typ. 10 ns) with 1 m cable and specified input circuit	
Connecting cable Cable length Signal propagation time	HEIDENHAIN shielded cables; e.g., PUR [4(2 × 0.14 mm ²) + (4 × 0.5 mm ²)] Max. 100 m ($\overline{U_{aS}}$ max. 50 m) Typ. 6 ns/m	

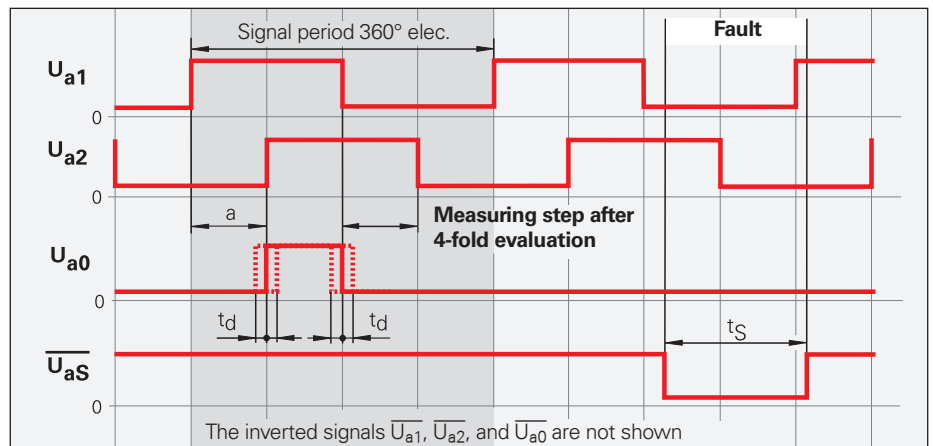

Clocked output signals are typical of encoders and signal converters with 5-fold interpolation (or higher). The edge separation a of these signals is derived from an internal clock source. At the same time, the clock frequency determines the permissible input frequency of the incremental signals ($1 V_{PP}$ or $11 \mu A_{PP}$) and thus the resulting maximum permissible shaft speed or traversing speed:

$$a_{nom} = \frac{1}{4 \cdot IPF \cdot fe_{nom}}$$

a_{nom} Nominal edge separation
 IPF Interpolation factor
 fe_{nom} Nominal input frequency

The tolerances of the internal clock source have an influence on the edge separation a of the output signal and the input frequency f_e , thereby influencing the traversing speed or shaft speed.

For the stated edge separation, these tolerances are already taken into account at 5%; in each case, it is not the nominal edge separation that is stated, but rather the minimum edge separation a_{min} .

For the maximum permissible input frequency, however, a tolerance of at least 5% must be taken into account. This means that the maximum permissible traversing speed or shaft speed is also reduced accordingly.

As a rule, encoders and signal converters without interpolation have **unclocked output signals**. The minimum edge separation a_{min} occurring at the maximum permissible input frequency is stated in the specifications. If the input frequency is reduced, then the edge separation correspondingly increases.

Cable-dependent differences in the propagation time additionally reduce the edge separation by 0.2 ns per meter of cable. In order to avoid counting errors, a safety margin of 10% must be taken into account. The downstream electronics are designed such that they can still process 90% of the resulting edge separation.

Please note:

The maximum permissible **shaft speed** or **traversing speed** must not be exceeded—even temporarily—because this will cause irreversible counting errors.

Example calculation 1

LIDA 400 linear encoder

Requirements: display step: 0.5 μ m; traversing speed: 1 m/s; output signals: TTL; cable length to downstream electronics: 25 m.

What is the minimum edge separation that the downstream electronics must be able to process?

Selection of the interpolation factor

20 μ m grating period : 0.5 μ m display step =	40-fold subdivision
Evaluation of the downstream electronics	4-fold
Interpolation	10-fold

Selection of the edge separation

Traversing speed	60 m/min (equivalent to 1 m/s)
+ tolerance value: 5%	63 m/min

Select in the specifications:

Next LIDA 400 version	120 m/min (from the specifications)
-----------------------	-------------------------------------

Minimum edge separation 0.22 μ s (from the specifications)

Determining the edge separation that the downstream electronics must process

Subtract cable-dependent differences in the propagation time	0.2 ns per meter
For cable length of 25 m	5 ns
Resulting edge separation	0.215 μ s
Subtract 10% safety margin	0.022 μ s

Minimum edge separation for the downstream electronics 0.193 μ s

Example calculation 2

ERA 4000 angle encoder with 32 768 lines

Requirements: measuring step of 0.1"; TTL output signals (IBV external signal converter required); cable length from IBV to downstream electronics: 20 m; minimum edge separation that the downstream electronics can process: 0.5 μ s (input frequency: 2 MHz).

What shaft speed is possible?

Selection of the interpolation factor

32 768 lines corresponds to	a signal period of 40"
Signal period of 40": measuring step of 0.1" =	400-fold subdivision
Evaluation of the downstream electronics	4-fold
Interpolation in the IBV	100-fold

Calculation of the edge separation

Permissible edge separation of the downstream electronics	0.5 μ s
<i>This corresponds to 90% of the resulting edge separation</i>	
Therefore: resulting edge separation	0.556 μ s
Subtract cable-dependent differences in the propagation time	0.2 ns per meter
For cable length of 20 m	4 ns
Minimum edge separation IBV 102	$\geq 0.56 \mu$s

Selecting the input frequency

With the IBV 102, the input frequencies and thus the edge separation a are adjustable as per the Product Information document.

Next suitable edge separation	0.585 μ s
Input frequency at 100-fold interpolation	4 kHz

Calculating the permissible shaft speed

Subtract 5% tolerance	3.8 kHz
-----------------------	---------

This is 3800 signals per second, or 228 000 signals per minute.

With the 32 768 lines of the ERA 4000, the following applies:

Maximum permissible shaft speed 6.95 rpm

The permissible **cable length** for the transmission of the TTL square-wave signals to the downstream electronics depends on the edge separation a . The maximum cable length is 100 m or 50 m for the fault detection signal. The required supply voltage must be applied at the encoder (see the specifications). Over the sense lines, the voltage at the encoder can be monitored and adjusted as needed by a suitable regulating device (remote sense power supply).

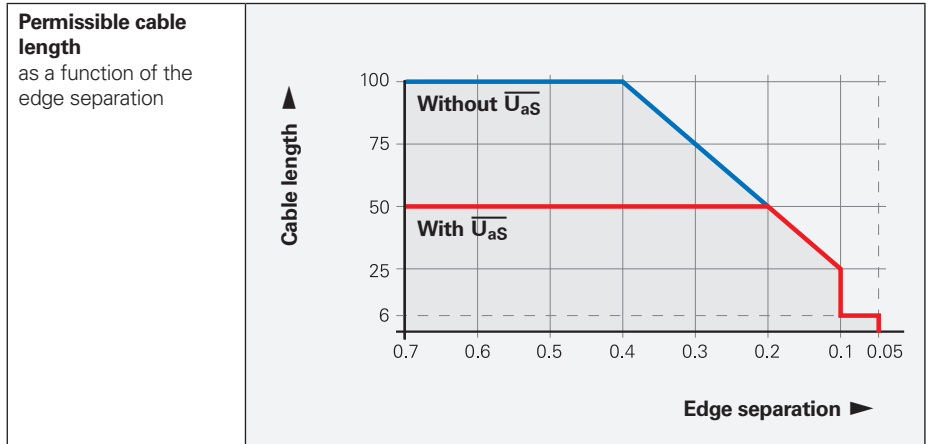

Input circuit design of the downstream electronics

Dimensioning

IC_1 = Recommended differential line receiver:

- DS 26 C 32 AT
- Only for $a > 0.1 \mu s$:
- AM 26 LS 32
- MC 3486
- SN 75 ALS 193

$R_1 = 4.7 \text{ k}\Omega$

$R_2 = 1.8 \text{ k}\Omega$

$Z_0 = 120 \Omega$

$C_1 = 220 \text{ pF}$ (serves to improve noise immunity)

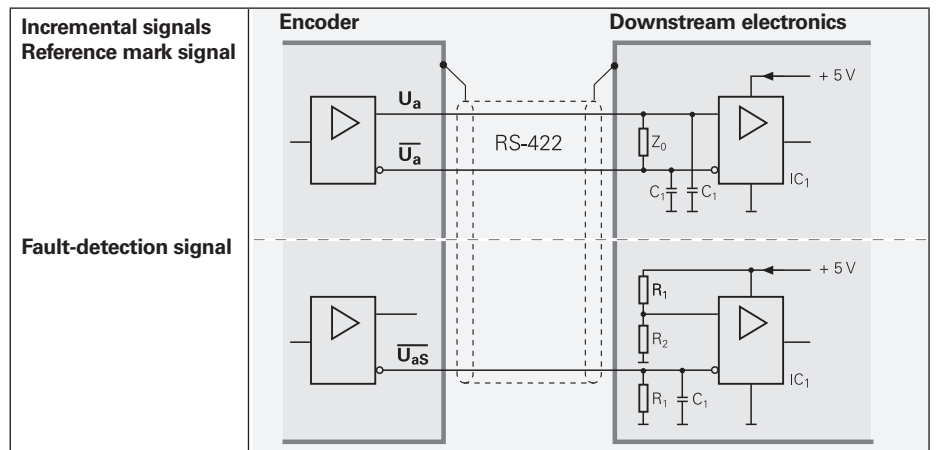

HTL square-wave signals

HEIDENHAIN encoders with the HTL interface incorporate electronics that digitize sinusoidal scanning signals with or without interpolation.

The **incremental signals** are transmitted as the square-wave pulse trains U_{a1} and U_{a2} , phase-shifted by 90° elec. The **reference mark signal** consists of one or more reference pulses U_{a0} , which are gated with the incremental signals. In addition, the integrated electronics generate the **inverted signals** $\overline{U_{a1}}$, $\overline{U_{a2}}$, and $\overline{U_{a0}}$ for noise-immune transmission (not with HTLs). The illustrated sequence of output signals—with U_{a2} lagging U_{a1} —applies to the direction of motion shown in the dimension drawing.

The **fault-detection signal** $\overline{U_{aS}}$ indicates malfunctions such as a failure of the light source. In automated manufacturing, for example, it can be used for machine switch-off.

The distance between two successive edges of the incremental signals U_{a1} and U_{a2} through 1-fold, 2-fold, or 4-fold evaluation is one **measuring step**.

The downstream electronics must be designed to detect each edge of the square-wave pulse. The minimum **edge separation a** stated in the specifications refers to a measurement at the output of the stated differential input circuit. To prevent counting errors, the downstream electronics should be designed to still be able to process 90% of the edge separation a .

The maximum permissible **shaft speed** or **traversing speed** must never be exceeded.

The permissible **cable length** for incremental encoders with HTL signals is dependent on the output frequency, the supply voltage being applied, and the operating temperature of the encoder.

The **current consumption** of encoders with HTL output signals depends on the output frequency and the cable length to the downstream electronics.

Interface	HTL, HTLs square-wave signals	
Incremental signals	Two HTL square-wave signals U_{a1} , U_{a2} and their inverted signals $\overline{U_{a1}}$, $\overline{U_{a2}}$ (HTLs without $\overline{U_{a1}}$, $\overline{U_{a2}}$)	
Reference mark signal Pulse width Delay time	One or more HTL square-wave pulses U_{a0} and their inverse pulses $\overline{U_{a0}}$ (HTLs without $\overline{U_{a0}}$) 90° elec. (other widths upon request) $ t_d \leq 50$ ns	
Fault-detection signal Pulse width	One HTL square-wave pulse $\overline{U_{aS}}$ Malfunction: LOW Proper functioning: HIGH $t_s \geq 20$ ms	
Signal level	$U_H \geq 21$ V at $-I_H = 20$ mA $U_L \leq 2.8$ V at $I_L = 20$ mA	With supply voltage $U_P = 24$ V, without cable
Permissible load	$ I_L \leq 100$ mA $C_{load} \leq 10$ nF	Max. load per output, (except $\overline{U_{aS}}$) With respect to 0 V Outputs can tolerate a short to 0 V and U_P for a maximum of 1 min (except $\overline{U_{aS}}$)
Switching times (10% to 90%)	$t_+/t_- \leq 200$ ns (except $\overline{U_{aS}}$) with 1 m cable and specified input circuit	
Connecting cable Cable length Signal propagation time	HEIDENHAIN shielded cables; e.g., PUR [4(2 × 0.14 mm ²) + (4 × 0.5 mm ²)] Max. 300 m (HTLs max. 100 m) 6 ns/m	

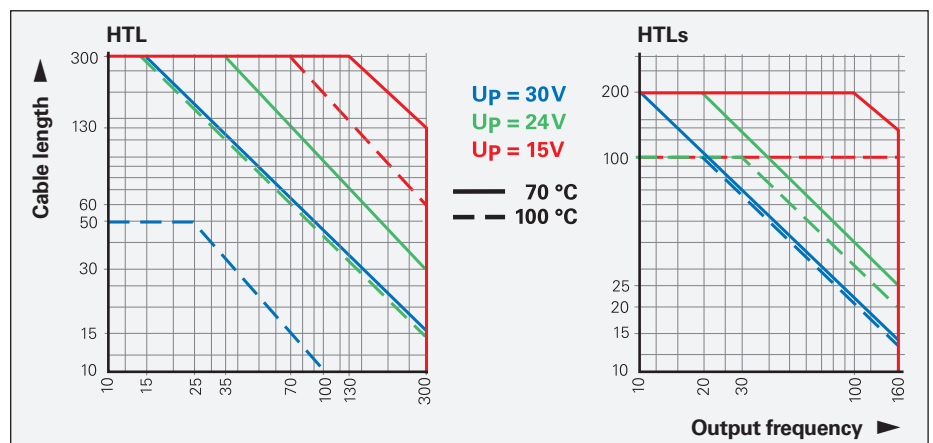
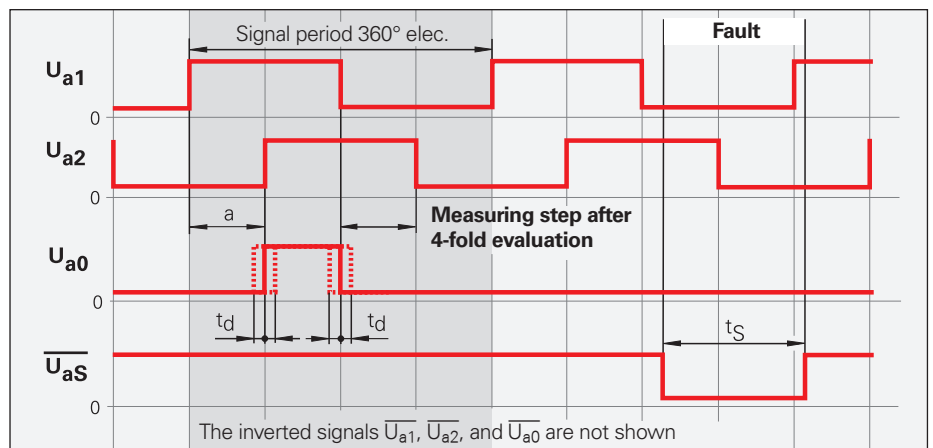

Input circuit design of the downstream electronics HTL

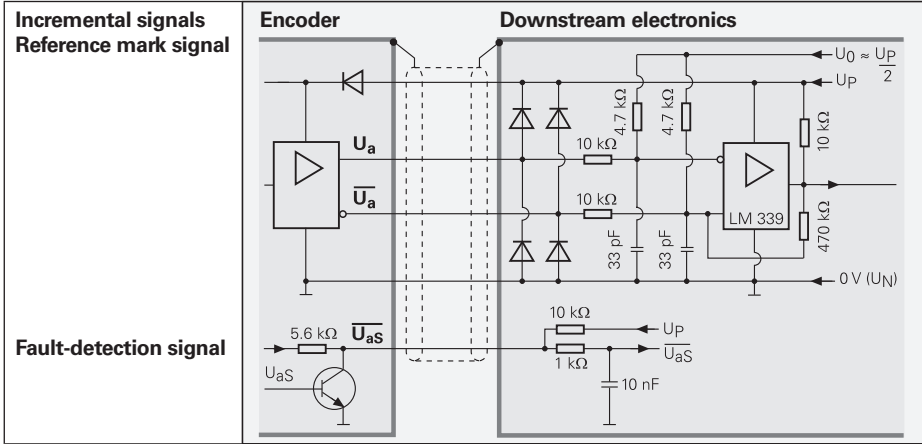

HTLs

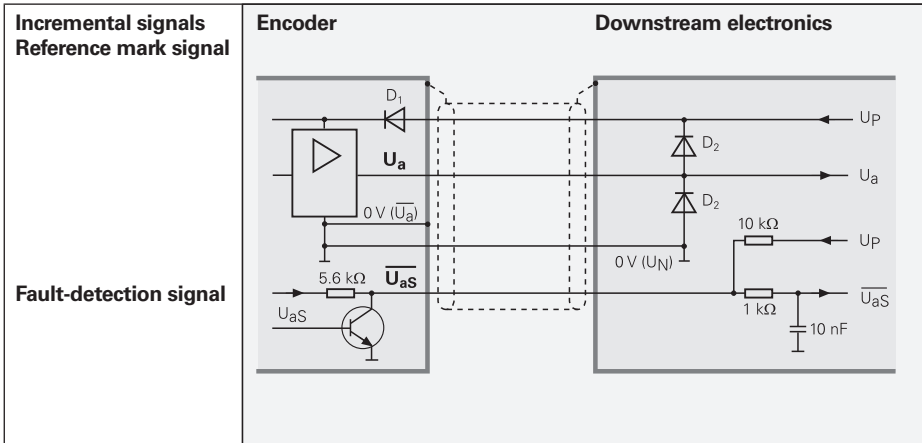

Other signals

Commutation signals for block commutation

The **block commutation signals U, V, and W** are derived from three separate tracks. They are transmitted as square-wave signals in TTL levels.

Interface	□ TTL square-wave signals
Commutation signals Width Signal level	Three square-wave signals U, V, W and their inverted signals $\bar{U}, \bar{V}, \bar{W}$ 2x180° mech., 3x120° mech., or 4x90° mech. (others upon request) See <i>Incremental signals</i> □ TTL
Incremental signals	See <i>Incremental signals</i> □ TTL
Connecting cable Cable length Signal propagation time	HEIDENHAIN shielded cables; e.g., PUR [6(2 x 0.14 mm ²) + (4 x 0.5 mm ²)] Max. 100 m 6 ns/m

Commutation signals

(values in mechanical degrees)

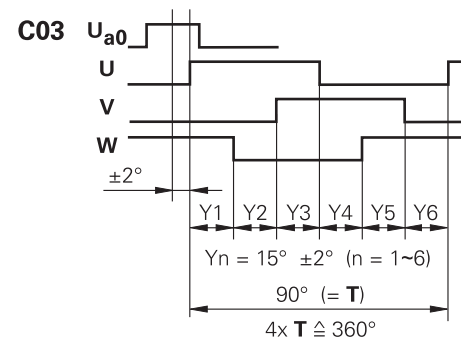
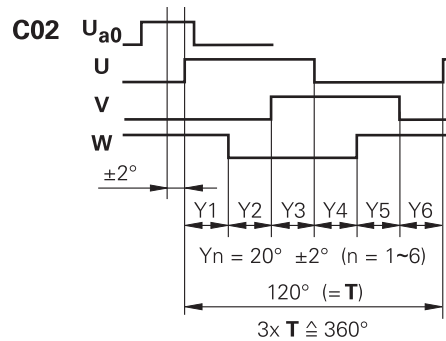
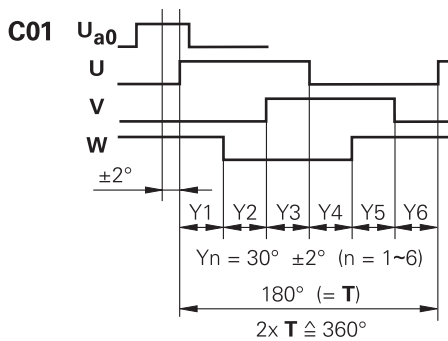

Commutation signals for sine commutation

The **commutation signals C and D** are obtained from the Z1 track and are equivalent to one sine or cosine period per revolution. They have a signal amplitude of typically $1 V_{PP}$ at $1 k\Omega$. The input circuit design of the downstream electronics is the same as for the $\sim 1 V_{PP}$ interface. The required terminating resistance Z_0 , however, is $1 k\Omega$ instead of 120Ω .

Interface	$\sim 1 V_{PP}$ sinusoidal voltage signals
Commutation signals	Two nearly sinusoidal signals C and D For the signal level, see <i>Incremental signals</i> $\sim 1 V_{PP}$
Incremental signals	See <i>Incremental signals</i> $\sim 1 V_{PP}$
Connecting cable	HEIDENHAIN shielded cables; e.g., PUR [4(2 x 0.14 mm ²) + (4 x 0.14 mm ²) + (4 x 0.5 mm ²)] Max. 150 m 6 ns/m
Cable length Signal propagation time	

Electronic commutation with Z1 track

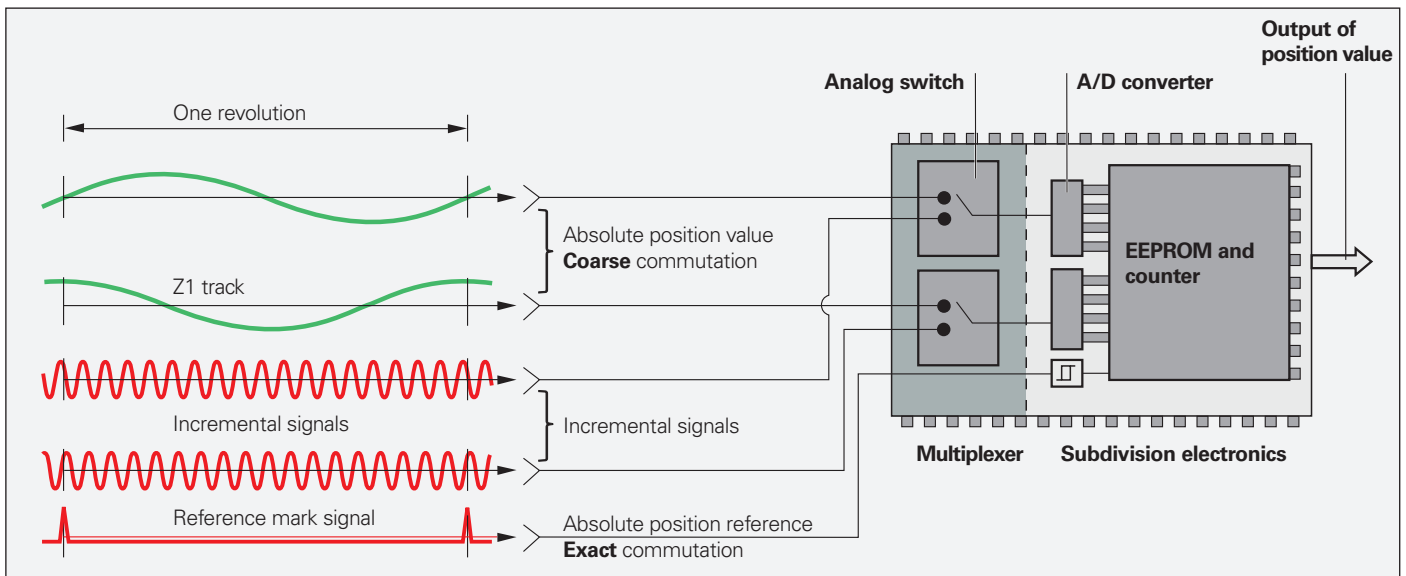

Limit switches

Encoders with limit switches, such as LIDA 400, are equipped with two limit switches that make limit-position detection and the formation of homing tracks possible. The limit switches are activated by differing adhesive magnets, thereby permitting precise switching of the right or left limit switches. The magnets can be configured in series for the creation of homing tracks.

The signals from the limit switches are output over separate lines and are thus directly available.

		LIDA 4xx
Output signals		HIGH/LOW level for each 1 TTL square-wave pulse for limit switches L1 and L2
Signal amplitude		Collector stage with load resistance of 10 kΩ against 5 V
Permissible load		$I_{aL} \leq 4 \text{ mA}$ $I_{aH} \leq 4 \text{ mA}$
Switching times (10% to 90%)	Rise time Fall time	$t_+ \leq 10 \mu\text{s}$ $t_- \leq 3 \mu\text{s}$ Measured with 3 m cable and recommended input circuit design
Permissible cable length		Max. 20 m

mm

 Tolerancing ISO 8015
 ISO 2768 - m H
 $\leq 6 \text{ mm}$: $\pm 0.2 \text{ mm}$

L1/L2 = Output signals of limit switches 1 and 2
 Tolerance of the switching edge: $\pm 2 \text{ mm}$

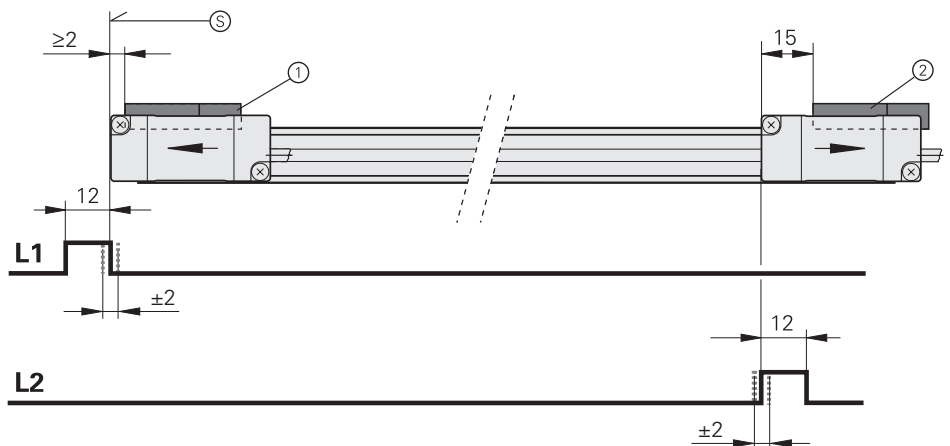
⊙ = Beginning of measuring length ML
 1 = Magnet N for limit switch 1
 2 = Magnet S for limit switch 2



Input circuit design of the downstream electronics

Dimensioning
 IC_3 (e.g., 74AC14)
 $R_3 = 1.5 \text{ k}\Omega$

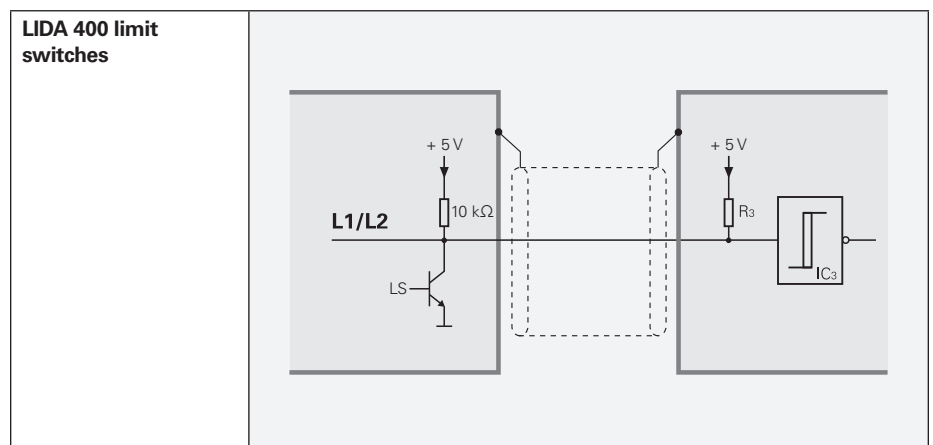

Position detection

In addition to having an incremental graduation, encoders with position detection, such as the LIF 4x1/LIP 60x1, feature a homing track and limit switches for limit position detection.

The signals are output in TTL levels over the separate lines H and L, and are therefore directly available.

With the LIP 60x1, fine adjustment of the limit/homing position can also be performed with the PWM 21.

	LIF 4x1/LIP 60x1
Output signals	One TTL pulse each for homing track H and limit switch L
Signal amplitude	TTL $U_H \geq 3.8\text{ V}$ at $-I_H = 8\text{ mA}$ $U_L \leq 0.45\text{ V}$ at $I_L = 8\text{ mA}$
Permissible load	$R \geq 680\ \Omega$ $ I_L \leq 8\text{ mA}$
Permissible cable length	Max. 10 m; for LIP 60x1 during adjustment with PWM 21, max. 3 m

LIP 60x1

mm

 Tolerancing ISO 8015
 ISO 2768 - m H
 $\leq 6\text{ mm}$: $\pm 0.2\text{ mm}$

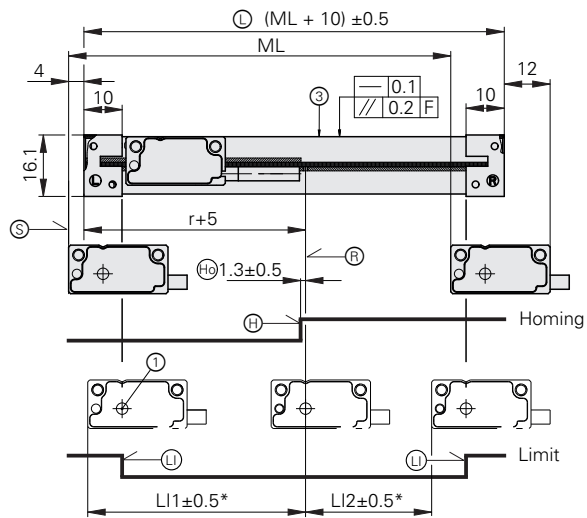
- Ⓜ = Reference mark position
- Ⓢ = Beginning of measuring length ML
- Ⓣ = Limit mark, adjustable
- Ⓤ = Switch for homing track
- Ⓥ = Trigger point for homing



LIF 4x1

mm

 Tolerancing ISO 8015
 ISO 2768 - m H
 ≤ 6 mm: ±0.2 mm

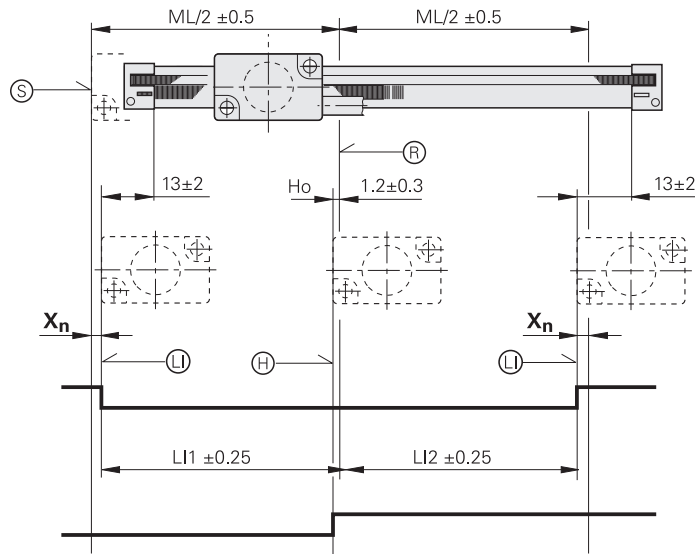
- Ⓜ = Reference mark position
- Ⓢ = Beginning of measuring length ML
- Ⓛ = Limit mark, adjustable
- Ⓜ = Switch for homing track
- Ho = Trigger point for homing



X_n =
 Var. 01 **X₁** = 2 mm
 Var. 02 **X₂** = 14 mm
 Var. 03 **X₃** = 22 mm

Input circuit design of the downstream electronics

Dimensioning
 IC₃ (e.g., 74AC14)
 R₃ = 4.7 kΩ

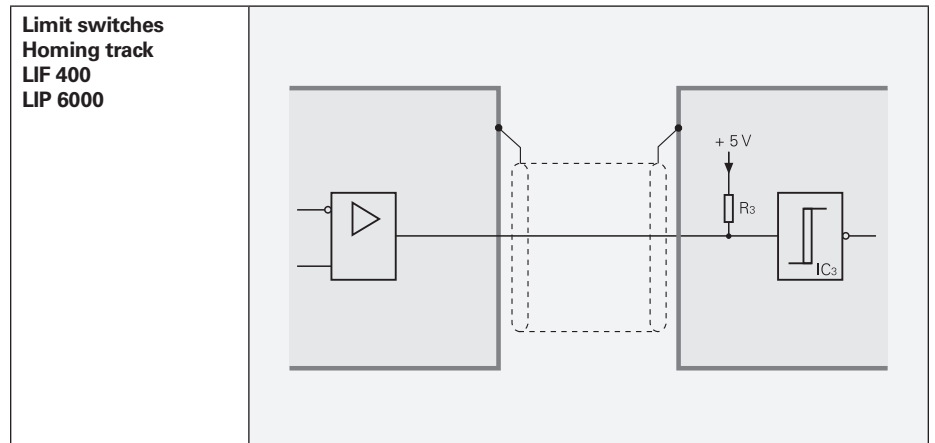

Further information

Signal converters

Signal converters from HEIDENHAIN enable the flexible adaptation of interfaces for encoder signals to the requirements of your application. Depending on the application, additional signals (such as temperature-sensor signals) may be processed and transmitted to the downstream electronics.

Input signals of the signal converters

HEIDENHAIN signal converters can be connected to encoders with 1 V_{PP} sinusoidal signals (voltage signals) or 11 μA_{PP} sinusoidal signals (current signals). Encoders with the EnDat or SSI serial interface can be connected to various signal converters as well.

Output signals of the signal converters

The signal converters are available with the following interfaces to the downstream electronics:

- TTL square-wave pulse trains
- EnDat 2.2
- DRIVE-CLiQ
- Fanuc Serial Interface
- Mitsubishi high speed interface
- Yaskawa Serial Interface
- PROFIBUS

Interpolation of the sinusoidal input signals

In addition to performing signal conversion, the signal converter also interpolates the sinusoidal encoder signals. This permits finer measuring steps, resulting in higher control quality and superior positioning behavior.

Generation of a position value

Various signal converters feature an integrated counter function. Starting from the last set reference point, an absolute position value is generated and output to the downstream electronics when the reference mark is crossed.

Box design



Plug design



Cable design



Top-hat rail design



Outputs		Inputs		Design – IP rating	Interpolation ¹⁾ or subdivision	Model
Interface	Quantity	Interface	Quantity			
□ TTL	1	~ 1 V _{PP}	1	Box design – IP65	5/10-fold	IBV 101
					20/25/50/100-fold	IBV 102
					Without interpolation	IBV 600
					25/50/100/200/400-fold	IBV 660B
				Plug design – IP40	5/10-fold	IBV 3171
					20/25/50/100-fold	IBV 3271
		~ 11 μA _{PP}	1	Box design – IP65	5/10-fold	EXE 101
					20/25/50/100-fold	EXE 102
□ TTL/ ~ 1 V _{PP} (adjustable)	2	~ 1 V _{PP}	1	Box design – IP65	2-fold	IBV 6072
					5/10-fold	IBV 6172
					5/10-fold and 20/25/50/100-fold	IBV 6272
EnDat 2.2	1	~ 1 V _{PP}	1	Box design – IP65	≤ 16384-fold subdivision	EIB 192
				Plug design – IP40	≤ 16384-fold subdivision	EIB 392
			2	Box design – IP65	≤ 16384-fold subdivision	EIB 1512
DRIVE-CLiQ	1	EnDat 2.2	1	Box design – IP65	–	EIB 2391 S
				Cable design – IP65	–	EIB 3392 S
Fanuc Serial Interface	1	~ 1 V _{PP}	1	Box design – IP65	≤ 16384-fold subdivision	EIB 192F
				Plug design – IP40	≤ 16384-fold subdivision	EIB 392F
			2	Box design – IP65	≤ 16384-fold subdivision	EIB 1592F
Mitsubishi high speed interface	1	~ 1 V _{PP}	1	Box design – IP65	≤ 16384-fold subdivision	EIB 192M
				Plug design – IP40	≤ 16384-fold subdivision	EIB 392M
			2	Box design – IP65	≤ 16384-fold subdivision	EIB 1592M
Yaskawa Serial Interface	1	EnDat 2.2	1	Plug design – IP40	–	EIB 3391Y
PROFIBUS DP	1	EnDat 2.2	1	Top-hat rail design	–	PROFIBUS gateway
PROFINET IO	1	EnDat 2.2	1	Top-hat rail design	–	PROFINET gateway

¹⁾ Switchable

Testing and inspection devices, and diagnostics

HEIDENHAIN encoders provide all of the information needed for initial setup, monitoring, and diagnostics. The type of information available depends on whether the encoder is incremental or absolute and on which interface is being used.

Incremental encoders have 1 V_{PP} TTL, or HTL interfaces. TTL and HTL encoders monitor their signal amplitudes internally and generate a simple fault detection signal. With 1 V_{PP} signals, an analysis of the output signals is possible only with external testing devices or through the use of computation resources in the downstream electronics (**analog diagnostics interface**).

Absolute encoders use serial data transmission. Depending on the interface, additional 1 V_{PP} incremental signals can be output. The signals are extensively monitored within the encoder. The monitoring results (particularly valuation numbers) can be transmitted to the downstream electronics along with the position values via the serial interface (**digital diagnostics interface**).

The following information is available:

- Error message: position value is not reliable
- Warning: an internal functional limit of the encoder has been reached
- Valuation numbers:
 - Detailed information about the encoder's function reserve
 - Identical scaling for all HEIDENHAIN encoders
 - Cyclic reading capability

This enables the downstream electronics to evaluate the current status of the encoder with little effort, even in closed loop mode.

For the analysis of these encoders, HEIDENHAIN offers the appropriate PWM inspection devices and PWT testing devices. Based on how these devices are integrated, a distinction is made between two types of diagnostics:

- Encoder diagnostics: the encoder is connected directly to the testing or inspection device, thereby enabling a detailed analysis of encoder functions.
- Monitoring mode: the PWM inspection device is inserted into the closed control loop (via suitable testing adapters as needed). This enables real-time diagnosis of the machine or equipment during operation. The available functions depend on the interface.

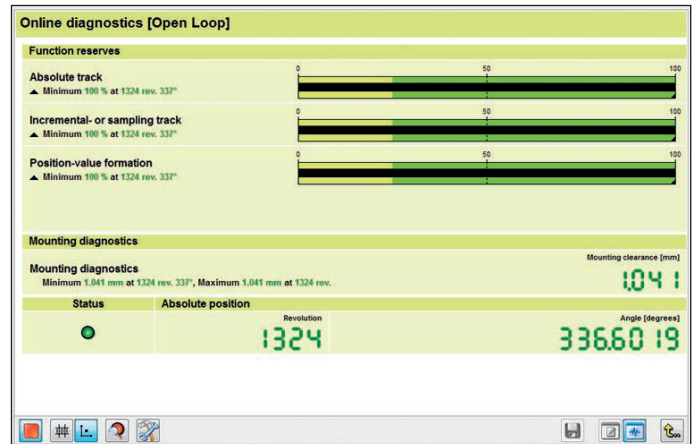

Diagnostics with the PWM 21 and ATS software

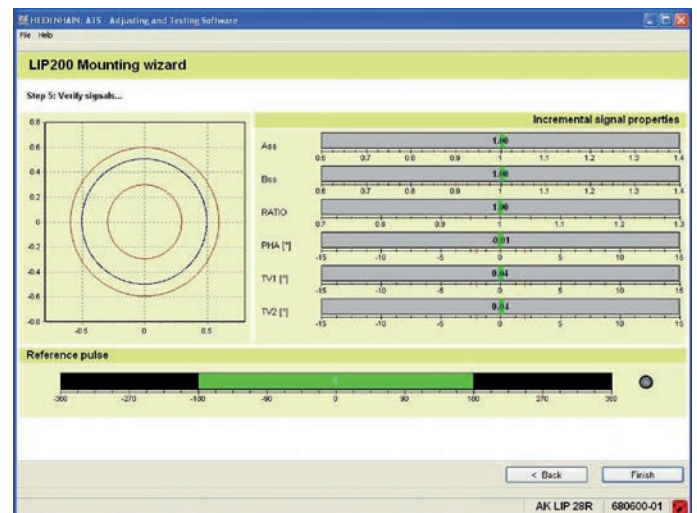

Initial setup with the PWM 21 and ATS software

Overview		PWM 21		PWT 101
Interface	Output signals (selection)	Encoder diagnostics	Monitoring mode	Encoder diagnostics
EnDat 2.1 (with incremental signals)	Position value Incremental signals	Yes Yes	No Yes	Yes Yes
EnDat 2.2 (without incremental signals)	Position value Valuation numbers	Yes Yes	Yes Yes ¹⁾	Yes Yes
DRIVE-CLiQ	Position value Valuation numbers	Yes Yes	No No	No ⁷⁾ No ⁷⁾
Fanuc	Position value Valuation numbers	Yes Yes	Yes Yes	Yes ⁸⁾ Yes ⁸⁾
Mitsubishi	Position value Valuation numbers	Yes Yes ⁵⁾	Yes Yes ^{1) 5)}	Yes ⁸⁾ Yes ⁸⁾
Panasonic	Position value Valuation numbers	Yes Yes	Yes Yes ¹⁾	Yes ⁸⁾ Yes ⁸⁾
Yaskawa	Position value Valuation numbers	Yes Yes ⁶⁾	No ⁷⁾ No ⁷⁾	Yes ⁸⁾ Yes ⁸⁾
SSI	Position value Incremental signals	Yes Yes	No Yes	No No
1 V_{PP}	Incremental signals	Yes	Yes	Yes
11 μA_{PP}	Incremental signals	Yes	Yes	Yes
TTL	Incremental signals Scanning signals	Yes Yes ⁴⁾	Yes No	Yes Yes ⁴⁾
HTL	Incremental signals	Yes ²⁾	No	No ⁷⁾
Commutation	Block commutation Sinusoidal commutation	Yes ²⁾ Yes	No Yes	Yes ³⁾ Yes

¹⁾ Information must be requested and transferred by the control

²⁾ Via the appropriate signal adapter

³⁾ Only for encoders with block commutation (see encoder documentation)

⁴⁾ If supported by the encoder (PWT function)

⁵⁾ Not available for encoders with the ordering designation Mitsu01

⁶⁾ Not available for the EIB 3391Y

⁷⁾ Function not yet available

⁸⁾ Two-pair transmission is required (for more information, see the documentation for the PWT 100/PWT 101)

PWT 101

The PWT 101 is a testing device for the functional testing and adjustment of incremental and absolute HEIDENHAIN encoders. Thanks to its compact and rugged design, the PWT 101 is ideal for portable use.



	PWT 101
Encoder input only for HEIDENHAIN encoders	<ul style="list-style-type: none"> • EnDat 2.1 or EnDat 2.2 (with or without incremental signals) • Fanuc Serial Interface • Mitsubishi high speed interface • Panasonic Serial Interface • Yaskawa Serial Interface • 1 V_{PP} • 11 μA_{PP} • TTL
Display	4.3-inch touchscreen
Supply voltage	DC 24 V Power consumption: max. 15 W
Operating temperature	0 °C to 40 °C
Protection EN 60529	IP20
Dimensions	Approx. 145 mm x 85 mm x 35 mm

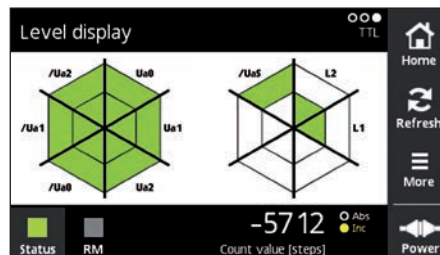

Level display



PWT display

Mounting wizard

The PWM 21, together with the adjusting and testing software (ATS), is recommended for the mounting of exposed or multi-section linear encoders or modular angle encoders. If supported by the encoder interface, the PWT 101 can be used as well to a limited extent.

Encoders*	Suitability of PWT 101
LIC 21xx, LIC 31xx, LIF 4xx, LIF 1xx, LIDA 4xx, LIDA 2xx, ERM 2xxx	✓
LIC 41xx, LIP 3xx, LB 3xx, LC 2xx, PP 281, ECA 4xxx, ECM 24xx, ERA 4xxx, ERA 7xxx, ERA 8xxx, ERP 880	Limited suitability: for optimal mounting quality, please use the PWM 21 with the ATS adjusting and testing software
LIP 2xx, LIP 6xxx, ERP 1xxx, ERO 2xxx	PWM 21 and ATS adjusting and testing software required

*Please read the notes in the encoder documentation

PWM 21

The PWM 21 phase angle measuring unit, in conjunction with the included ATS adjustment and testing software, provides an adjustment and testing package for the diagnosis and adjustment of HEIDENHAIN encoders.



For more information, see the *PWM 21, ATS Software* Product Information document.

	PWM 21
Encoder input	<ul style="list-style-type: none"> • EnDat 2.1 or EnDat 2.2 (with or without incremental signals) • EnDat 3 (signal adapter may be needed) • DRIVE-CLiQ • Fanuc Serial Interface • Mitsubishi high speed interface • Yaskawa Serial Interface • Panasonic serial interface • SSI • 1 V_{PP}/TTL/11 μA_{PP} • HTL (via signal adapter)
Interface	USB 2.0
Supply voltage	AC 100 V to 240 V or DC 24 V
Dimensions	258 mm × 154 mm × 55 mm

	ATS
Languages	German, English, French, Italian, Spanish, Korean, Chinese (simplified), Chinese (traditional)
Functions	<ul style="list-style-type: none"> • Position display • Connection dialog • Diagnostics • Mounting wizard for EBI/ECI/EQI, LIP 200, LIC 4000 and others • Additional functions (if supported by the encoder) • Memory contents
System requirements and recommendations	PC (dual-core processor > 2 GHz) RAM > 2 GB Operating system: Windows 7, 8, and 10 (32-bit/64-bit) 500 MB of free hard drive space

DRIVE-CLiQ is a registered trademark of Siemens AG.

Measuring principles

Incremental measuring method

With the incremental measuring method, the graduation consists of a periodic grating structure. The position information is obtained by counting the individual increments (measuring steps) from a chosen datum. The shaft speed or traversing speed is mathematically derived based on the change in position over time. Since an absolute position is needed in order to determine the absolute reference, the measuring standards feature an additional track that bears one or more reference marks. The measuring standard's absolute position, as defined by the reference mark, is assigned to exactly one measuring step or signal period. As a result, the reference mark must be scanned in order to establish an absolute reference or in order to find the most recently selected datum. In suboptimal cases, this may require machine movements over large sections of the measuring range. To make this easier,

many HEIDENHAIN encoders feature distance-coded reference marks: the reference mark track contains multiple reference marks at different defined distances. After two neighboring reference marks have been crossed without a change in direction, the downstream electronics can determine the absolute reference in less distance travelled. Scale drums or encoders with distance-coded reference marks are designated with the letter "C" at the end of the model designation (e.g., for the TTR ERM 2200C and ERA 4200C angle encoders, and the LS 487C linear encoder). With distance-coded reference marks, the absolute reference is calculated by counting the increments between two reference marks and using the formulas shown below.

Absolute measuring method

In the **absolute measuring method**, the position value is available immediately upon encoder switch-on and can be requested by the downstream electronics at any time. There is therefore no need to search for the reference position by jogging the axes. This absolute position information is read **from the measuring standard**, which features a serial code structure. To obtain the position value, a separate incremental track is interpolated.

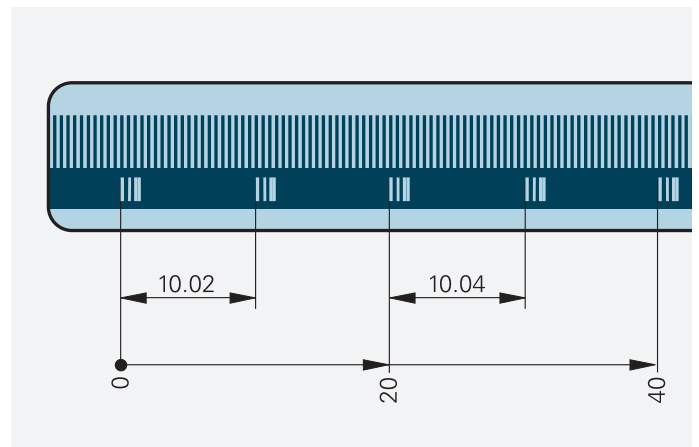
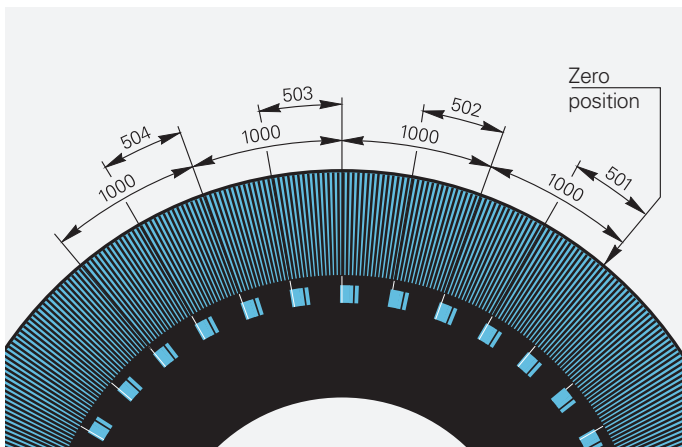

Angle encoders:

$$\alpha_1 = (\text{abs } A - \text{sgn } A - 1) \times \frac{N}{2} + (\text{sgn } A - \text{sgn } D) \times \frac{\text{abs } M_{RR}}{2}$$

and:

$$A = \frac{2 \times \text{abs } M_{RR} - N}{GP}$$

Definitions:

- α_1 = Absolute angular position of the first reference mark traversed relative to the zero position in degrees
- abs = Absolute value
- sgn = Algebraic sign function (= "+1" or "-1")
- M_{RR} = Measured value between the traversed reference marks in degrees
- N = Nominal increment between two fixed reference marks (see tables)
- GP = Graduation period ($\frac{360^\circ}{\text{Line count}}$)
- D = Direction of rotation (+1 or -1)
The rotation as per mating dimensions result in "+1"

Linear encoders:

$$P_1 = (\text{abs } R - \text{sgn } R - 1) \times \frac{N}{2} + (\text{sgn } R - \text{sgn } D) \times \frac{\text{abs } M_{RR}}{2}$$

and:

$$R = 2 \times M_{RR} - N$$

Definitions:

- P_1 = Position of the first traversed reference mark in signal periods
- abs = Absolute value
- sgn = Algebraic sign function (" +1 " or " -1 ")
- M_{RR} = Number of signal periods between the traversed reference marks
- N = Nominal increment between two fixed reference marks in signal periods (see table below)
- D = Direction of travel (+1 or -1). Traverse of scanning unit to the right (when properly installed) equals +1

General electrical information

Scope

The *General electrical information* applies to HEIDENHAIN encoders, signal converters, and cables. For any deviating information, see the specifications. Throughout the General electrical information chapter, the term "encoders" refers to HEIDENHAIN encoders and HEIDENHAIN signal converters.

Power supply

Connect HEIDENHAIN encoders only to downstream electronics whose supply voltage comes from PELV systems (for a definition of terminology, see EN 60204-1).

Encoders meet the requirements of the IEC 61010-1 standard if power is supplied from a secondary circuit with limited energy (low voltage, limited energy) as per IEC 61010-1^{3rd Ed.}, Section 9.4, or from a Class 2 secondary circuit as per UL1310.¹⁾

When indicated in the certificate, encoders that are certified for functional safety also meet the requirements of the IEC 61800-5-3 standard if power is supplied from a secondary circuit with the relevant DVC A volt class.

A **stabilized DC voltage U_P** is required for powering the encoders. Information on voltage and current consumption or power consumption can be obtained from the

respective specifications. Regarding the ripple voltage of the DC power, the following parameters apply:

- High-frequency interference signal $U_{PP} < 250 \text{ mV}$ with $dU/dt > 5 \text{ V}/\mu\text{s}$
- Low-frequency fundamental ripple $U_{PP} < 100 \text{ mV}$

However, the limits of the supply voltage must not be violated by the ripple content.

The voltage values must be complied with at the encoder. For encoders with an integrated cable assembly, the voltage drop in this cable assembly must be taken into account. Further information (e.g., the cross section of the supply wires) must be taken from the encoder documentation as needed. The voltage applied to the encoder can be monitored and adjusted via the **sense lines**, if present. If a variable power supply unit is not available, then the voltage drop can be reduced by connecting the sense lines in parallel with the corresponding supply wires.

When designing the power supply, use the maximum current or power consumption according to the specifications.

For the sake of comparison and for inspection purposes, the typical current consumption and power consumption at typical ambient and operating conditions without load (only supply voltage connected) are specified for the typical supply voltage or rated voltage. This information is non-binding and subject to change without notice.

The voltage U_P actually applied at the encoder is to be considered when **calculating the current consumption and power consumption of the encoder**. This voltage consists of the supply voltage U_E provided by the downstream electronics minus the **voltage drop ΔU** on the supply wires.

The required supply voltage depends on the encoder interface. A distinction is made between encoders without an extended supply voltage range (e.g., DC 5.0 V \pm 0.25 V) and those with an extended supply voltage range (e.g., DC 3.6 V to 14 V).

Encoders with an extended supply voltage range

For encoders with an extended supply voltage range, the relationship between the current consumption and the supply voltage is non-linear. However, the power consumption of the encoder exhibits a nearly linear curve (see power consumption and current consumption graph).

¹⁾ In place of IEC 61010-1^{3rd Ed.}, Section 9.4, the corresponding sections of the standards DIN EN 61010-1, EN 61010-1, UL 61010-1, and CAN/CSA-C22.2 No. 61010-1, can be used as well.

Current consumption and power consumption as a function of the supply voltage (example)

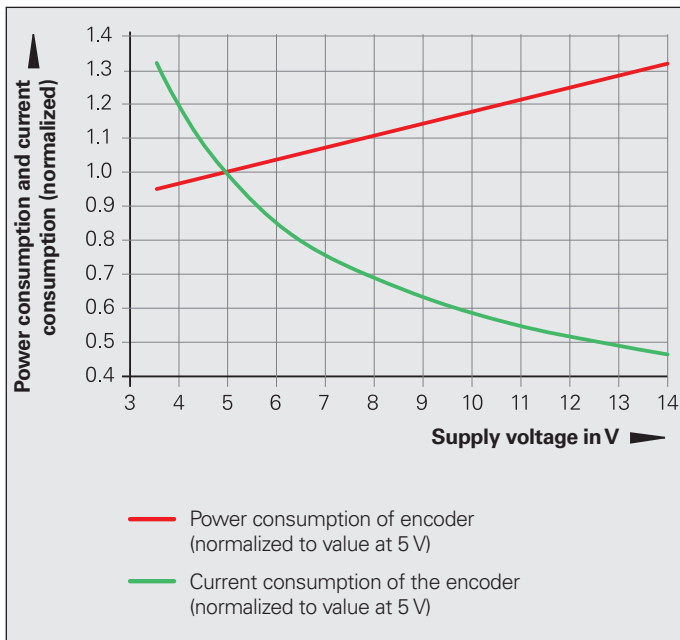

Influence of the cable length on the power output of the downstream electronics (example)

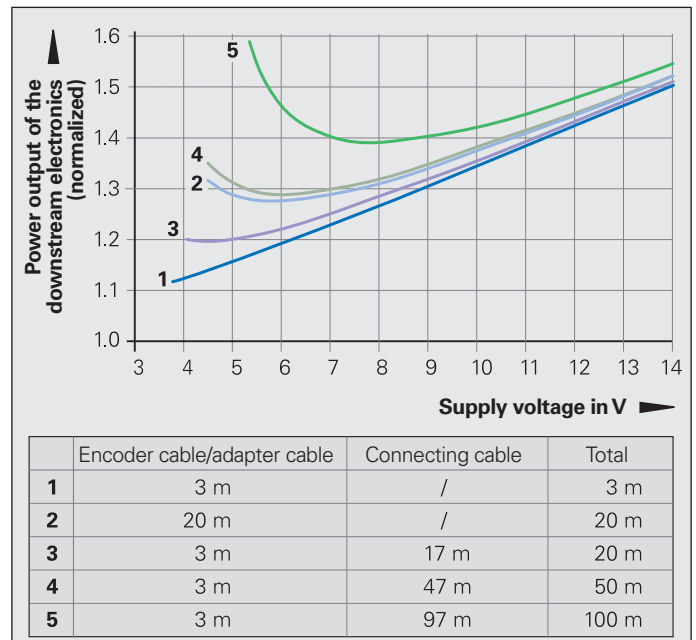

For this reason, the specifications provide the maximum power consumption at the minimum and maximum supply voltage. The maximum power consumption takes the following factors into account:

- The recommended receiver circuit
- A cable length of 1 m
- Age and temperature influences
- Proper use of the encoder with respect to the clock frequency and cycle time

For **encoders with an extended supply voltage range**, the calculation of the voltage drop ΔU on the supply wires must take the non-linear current consumption into account. This occurs in three steps:

Step 1: Resistance of the supply wires

The resistance of the supply wires (adapter cable and connecting cable) can be calculated with the following formula:

$$R_L = 2 \cdot \frac{1.05 \cdot L_C}{56 \cdot A_P}$$

Step 2: Coefficients for calculation of the voltage drop

$$b = R_L \cdot \frac{P_{Mmax} - P_{Mmin}}{U_{Pmax} - U_{Pmin}} + U_E$$

$$c = P_{Mmin} \cdot R_L + \frac{P_{Mmax} - P_{Mmin}}{U_{Pmax} - U_{Pmin}} \cdot R_L \cdot (U_E - U_{Pmin})$$

Step 3: Voltage drop based on the coefficients b and c

$$\Delta U = 0.5 \cdot (b - \sqrt{b^2 - 4 \cdot c})$$

Encoders without an extended supply voltage range

For encoders without an extended supply voltage range (typical supply voltage: DC 5 V), the voltage drop ΔU on the supply wires is calculated as follows:

$$\Delta U = 2 \cdot \frac{1.05 \cdot L_C}{56 \cdot A_P} \cdot I_M \cdot 10^{-3}$$

If the value for the voltage drop ΔU is known, then the following parameters can be calculated for the encoder and downstream electronics: voltage at the encoder, current consumption of the encoder, power consumption of the encoder, and the power to be provided by the downstream electronics.

Voltage at the encoder:

$$U_P = U_E - \Delta U$$

Current consumption of the encoder:

$$I_M = \frac{\Delta U}{R_L}$$

Power consumption of the encoder:

$$P_M = U_P \cdot I_M$$

Power output of the downstream electronics:

$$P_E = U_E \cdot I_M$$

If a HEIDENHAIN encoder is operated on a downstream device via a **HEIDENHAIN signal converter**, then the power consumption of the encoder and the power consumption of the signal converter must be added to determine the resulting power consumption.

Depending on the signal converter, a compensation factor for the efficiency of the interface signal converter's switching power supply may have to be taken into account (see the respective Product Information document).

Definitions:

U_P	Voltage at the encoder in V
I_M	Current consumption of the encoder in mA
P_M	Power consumption of the encoder in W
U_E	Supply voltage at the downstream electronics in V
P_E	Power output of the downstream electronics in W
ΔU	Voltage drop over the cable in V
L_C	Cable length in meters
A_P	Cross section of the supply wires in mm^2 (see cables)
2	Outgoing and incoming lines

1.05	Length factor due to twisted wires
56	Electrical conductivity of copper
R_L	Resistance of the supply wires (for both directions) in ohms
P_{Mmin}	Maximum power consumption in W at the minimum or maximum supply voltage
P_{Mmax}	
U_{Pmin}	Minimum or maximum supply voltage in V of the encoder
U_{Pmax}	

Encoder M to the downstream electronics E:

$$U_P = U_E - \Delta U_1$$

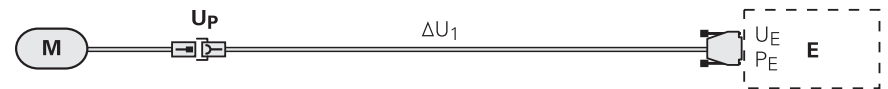
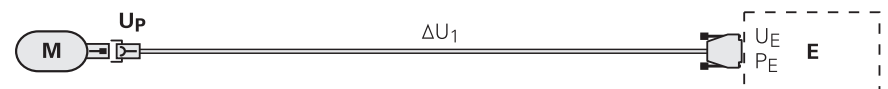

Signal converter between encoder M and downstream electronics E:

$$U_P = U_{P2} - \Delta U_2$$

$$U_{P1} = U_E - \Delta U_1$$

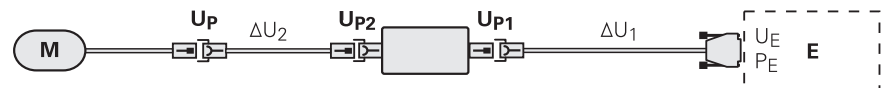
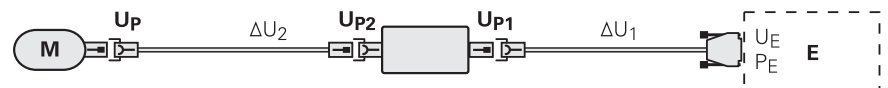

Cable lengths

Maximum cable lengths

The cable lengths in the specifications apply only to HEIDENHAIN cables and the recommended input circuit designs for the downstream electronics. The maximum attainable cable length is limited by the following key factors:

- Compliance with the supply voltage at the encoder
- Restrictions arising from the transmission technology (e.g., protocol design for purely serial interfaces and manufacturer specifications for proprietary interfaces)

Please note: These restrictions must be checked independently from each other and complied with.

The maximum overall length of the pre-assembled cables is provided in the table below.

EnDat 3	100 m
HMC 2	100 m
EnDat 2.2	100 m
HMC 6	100 m
DRIVE-CLiQ	100 m
Fanuc, Panasonic	30 m ¹⁾
Mitsubishi, Yaskawa	30 m
EnDat 2.1	150 m
SSI	100 m
1 V _{PP}	150 m
11 μA _{PP}	30 m
TTL	100 m

¹⁾ Lengths of up to 50 m are possible depending on the encoder

Please consider the specifications of the given encoder.

Compliance with the supply voltage at the encoder

The voltage drop may cause the supply voltage to fall below its minimum permissible level, particularly in the case of long cable lengths and encoders with high current requirements, such as absolute linear and angle encoders. The highest possible supply voltage U_P should therefore be selected in the downstream electronics. The voltage drop can be mitigated through the following measures:

- Keep thin cables with small wire cross-sections as short as possible
- For large cable lengths, select a wider wire cross section
- For downstream electronics without a variable power supply unit, connect the sense lines in parallel with the supply lines. This doubles the available cross-section

Data transfer technology

The transmission characteristics of the pre-assembled cables, protocol properties of the interfaces, and other specifications impose limitations on the design of the cable lengths.

Purely serial interfaces with transmission frequencies of up to 16 MHz, in combination with large cable lengths, place high technological demands on the cable. Thanks to a design that is specially adapted to these applications, HEIDENHAIN cables are highly suitable for meeting these requirements. For this reason, HEIDENHAIN recommends using original HEIDENHAIN cables.

An adapter cable connected directly to the encoder is limited in terms of its length. To implement larger cable lengths, an adapter cable and an additional connecting cable with a larger cross section can be used.

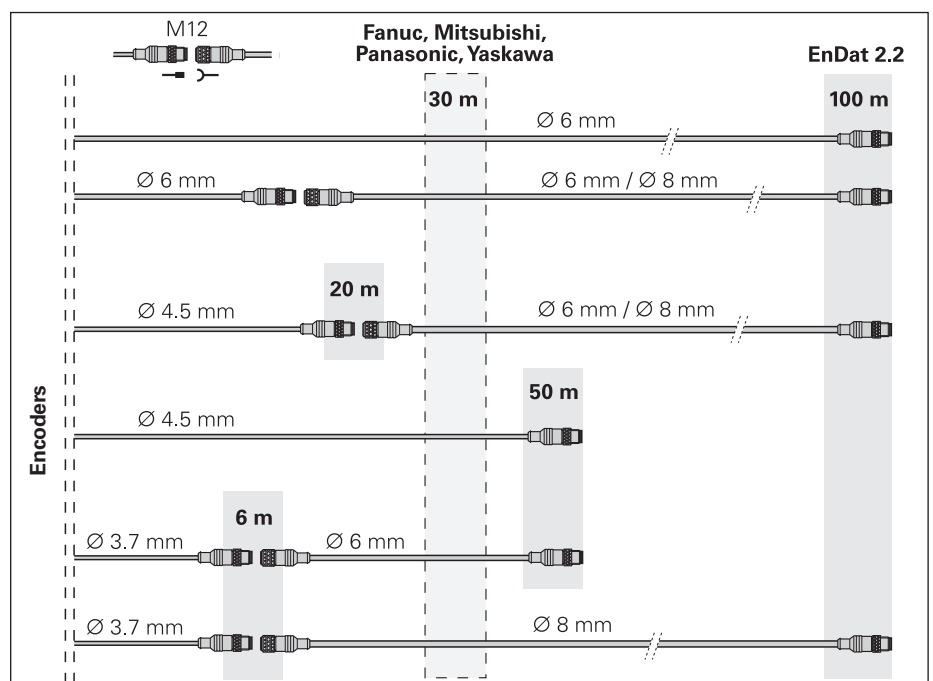

Cable lengths for purely serial interfaces

Encoder	Power consumption at $U_P = 3.6\text{ V}$ or 14 V	Additional connecting cable			
		Adapter cable $\varnothing 4.5\text{ mm}$ $A_P = 2 \times 0.16\text{ mm}^2$	Pre-assembled cable $\varnothing 6\text{ mm}$ $A_P = 2 \times 0.16\text{ mm}^2$	Pre-assembled cable $\varnothing 8\text{ mm}$ $A_P = 2 \times 0.35\text{ mm}^2$	
LC/RCN/ ROC	$3.6\text{ V} \leq 1100\text{ mW}$ $14\text{ V} \leq 1300\text{ mW}$	20 m 6 m 1 m	15 m 29 m 34 m	35 m 66 m 77 m	
ECN 1325	$3.6\text{ V} \leq 600\text{ mW}$ $14\text{ V} \leq 700\text{ mW}$	0.3 m	Output cable inside the motor housing	65 m	
EQN 1337	$3.6\text{ V} \leq 700\text{ mW}$ $14\text{ V} \leq 800\text{ mW}$	0.3 m			55 m
AK LIC 41x	$3.6\text{ V} \leq 950\text{ mW}$ $14\text{ V} \leq 1050\text{ mW}$	3 m 1 m	Output cable on the encoder	37 m 39 m	85 m 89 m

Maximum cable length for purely serial interfaces (determined based on a supply voltage of DC 4.9 V)

A major factor influencing the attainable maximum cable length is the supply voltage of the downstream electronics. At a supply voltage of DC 12 V ($\pm 10\%$), overall lengths of 100 m can be realized with HEIDENHAIN connecting cables for the encoders in the table. The value selected for the table, 4.9 V, represents the lower limit of the supply voltage of commercially available downstream electronics. The table shows examples of adapter cable length combinations ($\varnothing 4.5\text{ mm}$) for various encoders and the resulting maximum cable lengths of the connecting cable. The values in the table apply to a parallel connection of the sense lines and the supply lines. The attainable overall length is the sum of the lengths of the adapter cable and connecting cable.

Remarks:

- These values apply to the supply voltage $U_P = 4.9\text{ V}$ of the downstream electronics
- Cable lengths may be limited depending on the interface version of the encoder (see encoder data in the respective brochure; maximum value = 100 m)

- The stated power consumption values apply only to the current edition of the *Interfaces of HEIDENHAIN Encoders* brochure. For the currently valid power consumption values, please refer to the specifications in the relevant product brochure.
- Please also consider the information of the downstream electronics manufacturer regarding the supply voltage for the encoder and the maximum permissible cable lengths.

Note:

Depending on the encoder, other length limitations may apply. For more information, see the brochure and Product Information document of the encoder in question.

Switch-on/off behavior of the encoders

Valid output signals are available after the switch-on time t_{SOT} . During the time t_{SOT} , the output signals reach the maximum voltage values stated in the table. The duration of the switch-on time t_{SOT} depends on the interface.

Interface	Switch-on time	Maximum voltage	
1 V _{PP}	1.3 s	5.5 V	
11 μA _{PP}			
TTL			
HTL			
EnDat			U _{Pmax}
SSI			5.5 V
PROFIBUS DP	2 s	5.5 V	
PROFINET	10 s	U _{Pmax}	

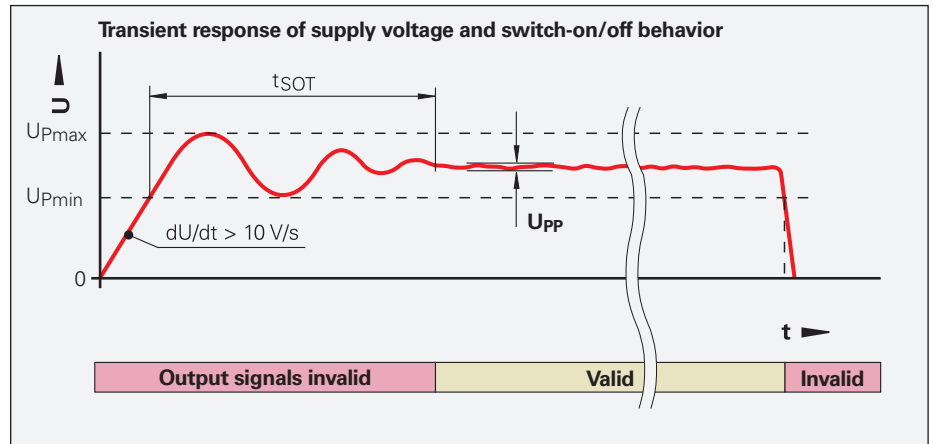

If the power supply is switched off, or if the supply voltage falls below U_{Pmin} , then the output signals are invalid as well. Furthermore, the interface-specific switch-on/off characteristics must be taken into account. If the HEIDENHAIN encoder is operated through an interposing HEIDENHAIN signal converter, then the signal converter's switch-on and switch-off conditions must also be taken into consideration.

Other proprietary interfaces supported by HEIDENHAIN are not dealt with here.

Design information regarding the power pack of the downstream electronics

Selecting the power supply of the downstream electronics

Select a power supply that is as close as possible to the upper tolerance limit. Consider the voltage drop ΔU resulting from the cable length. The power supply should lie within the upper tolerance range, particularly in the case of encoders with a supply voltage of DC 5 V ± 0.25 V and DC 5 V ± 0.5 V. For encoders with a supply voltage of DC 3.6 V to 14 V and functional safety, a supply voltage of DC 12 V is recommended.

Power output of the downstream electronics

For encoders with an extended supply voltage range, the maximum power consumption stated in the specifications must be taken into account. Particularly in the case of encoders with a supply voltage of DC 5 V, be sure to note that the power for the current consumption is indicated **without load**. Therefore, keep in mind that the current consumption values will be higher depending on the design of the receiver circuit. Losses in the adapter and connecting cables must also be taken into account.

Maximum current consumption at the moment of switch-on

The increased current consumption must be considered for the dimensioning of the power pack. HEIDENHAIN therefore recommends that the power pack be equipped with a current limit. The recommended value for the limit is 400 mA, but at least 1.2 times the value of the maximum current consumption of the encoder in steady state.

When dimensioning the current monitor with switch-off (especially trigger threshold and trigger speed), ensure that the increased current consumption can be tolerated at the moment of switch-on.

Data age

Due to signal propagation times, deviations from the current physical position of the encoder may arise

- in the encoder (for serial interfaces) and
- in the downstream electronics (for incremental interfaces).

The sum of the different signal propagation times is referred to as the data age. It causes a speed-dependent deviation of the determined position from the current physical position of the encoder.

Data age is determined by the signal propagation times in the analog and digital signal processing path of the encoder and the downstream electronics, as well as the propagation times in the transmission path. Due to the characteristics of the interface, the data age can be positive or negative.

For more information, refer to the encoder's specifications as needed (please consult with HEIDENHAIN as needed).

Electrically permissible shaft speed or traversing speed

The maximum permissible shaft speed or traversing speed of an encoder is derived from:

- the mechanically permissible shaft speed or traversing speed and
- the electrically permissible shaft speed or traversing speed.

In the case of incremental encoders with sinusoidal output signals, the electrically permissible shaft speed or traversing speed is limited by the $-3\text{dB}/-6\text{dB}$ cutoff frequency or the permissible input frequency of the downstream electronics.

For incremental encoders with square-wave signals, the electrically permissible shaft speed or traversing speed is limited by:

- the maximum permissible scanning/output frequency f_{max} of the encoder and
- the minimum permissible edge separation a for the downstream electronics.

For angle or rotary encoders

$$n_{\text{max}} = \frac{f_{\text{max}}}{z} \cdot 60 \cdot 10^3$$

For linear encoders

$$v_{\text{max}} = f_{\text{max}} \cdot \text{SP} \cdot 60 \cdot 10^{-3}$$

Definitions:

n_{max}	Electrically permissible shaft speed in rpm
v_{max}	Electrically permissible traversing speed in m/min
f_{max}	Maximum scanning frequency / output frequency of the encoder or the input frequency of the downstream electronics in kHz
z	Signal periods of the angle encoder or rotary encoder per 360°
SP	Signal periods of the linear encoder in μm

Scope

As a supplement to the *General electrical information*, the following sections apply to HEIDENHAIN encoders with a proprietary interface. For any deviating information, see the specifications.

Encoders with the DRIVE-CLiQ interface

Power supply

Encoders with the DRIVE-CLiQ interface are designed for a nominal voltage of DC 24 V. The manufacturer of the downstream electronics specifies DC 20.4 V to 28.8 V as the tolerance for the supply voltage.

Encoders with the DRIVE-CLiQ interface permit a larger voltage range (see the specifications). Operation at up to DC 36.0 V is briefly permissible. In the range of DC 28.8 V to 36.0 V, higher power consumption is to be expected.

Switch-on/off behavior

Encoders with the DRIVE-CLiQ interface are designed for the switch-on/switch-off behavior shown in the upper-right diagram.

Cable lengths

The cable lengths indicated in the specifications apply only in the case of HEIDENHAIN cables and the recommended input circuit designs for the downstream electronics.

The DRIVE-CLiQ interface permits a maximum cable length of 100 m, but this value is reduced by a number of factors:

- Number of dividing points with DRIVE-CLiQ couplings
- Length factor of the adapter or connecting cable
- Pluggable adapter cable at the encoder
- Length of the HEIDENHAIN adapter cable with compensation factor

The maximum permissible cable length for DRIVE-CLiQ is determined as follows:

$$n_{MG} \cdot 5 \text{ m} + \frac{4}{3} \cdot L_{AC} + \sum_i k_i \cdot L_i + n_C \cdot 5 \text{ m} \leq 100 \text{ m}$$

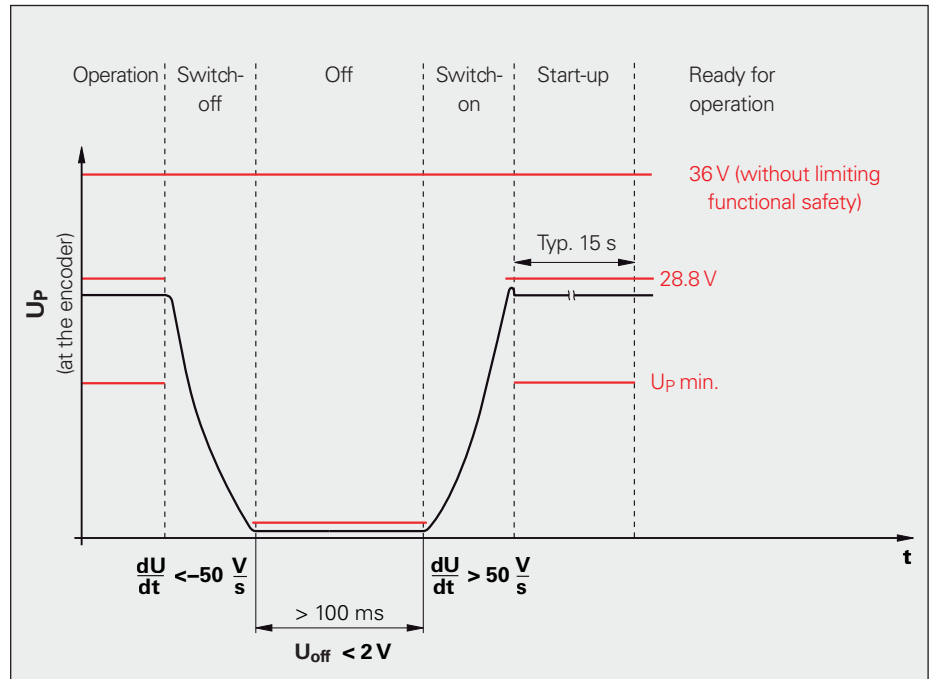

Switch-on/switch-off conditions for HEIDENHAIN encoders with the DRIVE-CLiQ interface

Definitions:

- n_{MG} : Influence of the encoder via a connectable adapter cable, for example; $n_{MG} = 1$
- 4/3: Length compensation factor for HEIDENHAIN adapter cables
- L_{AC} : Length of the HEIDENHAIN adapter cable in m
- k_i : Length compensation factor¹⁾ of the signal line i (4/3: for cables from HEIDENHAIN)
- L_i : Overall length¹⁾ of the signal line i in m
- n_C : Number of dividing points

Encoders with the DRIVE-CLiQ interface that are connected via an output cable (AGK) have an additional length limitation. Due to the transmission characteristics of the output cables, a 40 m limit applies to the formula for calculating the maximum permissible cable length. This limit applies to all output cables that have the designation "DQ01" in the "Use with" column of the cable overview list.

¹⁾ See the specifications of the manufacturer of the downstream electronics

Note:

Depending on the encoder, further length restrictions may apply. For more information, see the brochure or Product Information document of the given encoder.

DRIVE-CLiQ is a registered trademark of Siemens AG.

Electrical safety

HEIDENHAIN encoders must be supplied from PELV systems (for an explanation of terminology, see EN 60204-1); they are certified in accordance with IEC 61010-1, UL 61010-1, and CAN/CSA-C22.2 No. 61010-1.

When indicated in the certificate, encoders that are certified for functional safety also meet the requirements of the IEC 61800-5-3 standard if power is supplied from a secondary circuit with the relevant DVC A voltage class.

The housing of the encoders does not exhibit an electrical connection to internal electric circuits. Encoders with exposed electronics must be protected from damage and the ingress of outside contamination and liquids by means of a cover.

Electromagnetic compatibility

Sources of electrical interference

Electrical interference is primarily caused by capacitive or inductive couplings. Inductive couplings can arise on lines, as well as at device inputs and outputs.

Typical sources of electrical interference include the following:

- Strong magnetic fields from transformers, brakes, and electric motors
- Relays, contactors, and solenoid valves
- High-frequency equipment, pulse devices, and stray magnetic fields from switching power supplies
- Power cables and supply lines to the abovementioned devices

Conformity

If the measures listed below are complied with, then HEIDENHAIN encoders fulfill EMC Directive 2014/30/EU with regard to the generic standards for the given area of application:

• Immunity

Specifically, the following standards:

- ESD EN 61000-4-2
- Electromagnetic fields EN 61000-4-3
- Burst EN 61000-4-4
- Surge EN 61000-4-5
- Conducted disturbances EN 61000-4-6
- Power frequency magnetic fields EN 61000-4-8
- Voltage dips, short interruptions EN 61000-4-11

• Emission

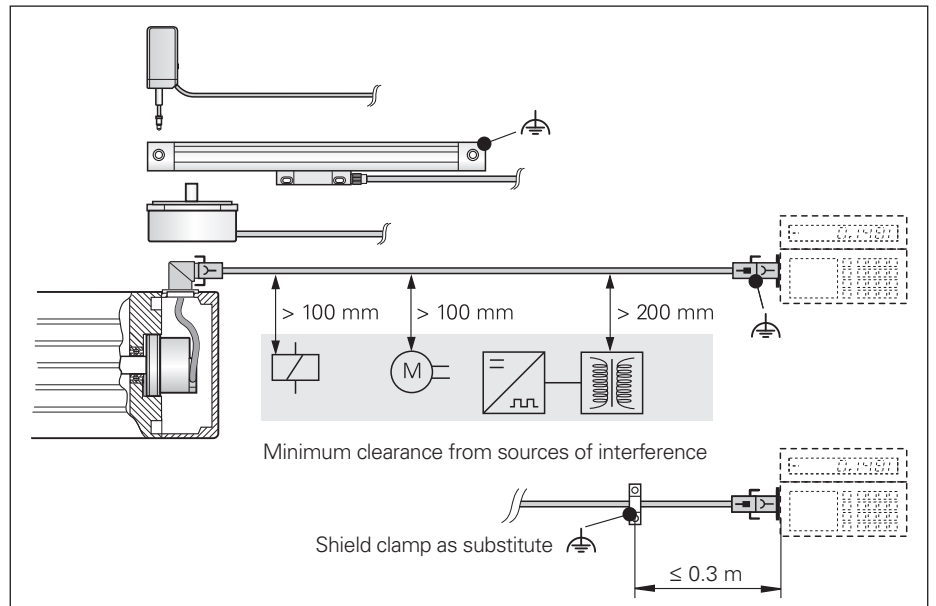

Measures

The EMC Directive requires the attainment of interference-free operation without the need for EMC expertise. The following measures serve to ensure this level of interference-free operation (please consult with HEIDENHAIN as needed):

- Properly install or mount encoders in accordance with the mounting instructions.
- Use only original HEIDENHAIN cables. Comply with the maximum permissible cable lengths for the respective interface. For usage that deviates from standard usage (assignment of signals and connectors), the manufacturer of the complete system must ensure conformity.
- Do not install cables in the immediate vicinity of interference sources (inductive consumers such as contactors, motors, frequency inverters, solenoid valves, etc.)
 - Sufficient decoupling from interference-signal-conducting cables can usually be achieved by an air clearance of 100 mm or, when cables are in metal ducts, by a grounded partition.
 - A minimum clearance of 200 mm from storage reactors in switching power supplies is required.
- Prevent accidental contact between the shield (e.g., connector) and other metal parts.
- For cables with an internal shield and external shield, connect the internal shield to 0 V on the downstream electronics (exception: the hybrid motor cable from HEIDENHAIN; see the documentation on the hybrid motor cable). Do not connect the internal shield with the external shield.
- Use connecting elements (e.g., connectors or terminal boxes) with metal housings. These connecting elements may be used only for the signals and supply voltage of the connected encoder (exception: the hybrid motor cable from HEIDENHAIN).
- Connect the encoder housing, connecting elements, and downstream electronics with each other by means of the cable shield. Connect the shield over a large area along the complete circumference (360°). For encoders with more than one electrical connection, refer to the documentation of the respective product.
- Install encoders with exposed electronics or a plastic housing in an enclosed metal housing. If other signals and sources of interference will pass through the housing, then EMC expertise is required, and the manufacturer of the complete system must ensure conformity.
- Connect the (external) shield with functional earth in accordance with the mounting instructions.
- For devices and cable assemblies with plastic connectors or connectors without a large-area shield connection, connect the (external) shield with functional earth over a large area just a short distance before the connector (shield clamp; see figure). There must be no source of interference in the immediate vicinity.
- For encoders that optionally enable the connection of an external sensor (e.g., a temperature sensor), conformity with the EMC Directive applies only to operation without an external sensor. For operation with an external sensor (e.g., temperature sensor) strong EMC expertise is required for interference-free operation, and the manufacturer of the overall system must ensure conformity:
 - Interference-free operation is possible in most applications because the disturbances acting on the sensor are low.
 - In addition, the requirements for the electrical insulation of the sensor must be considered because electrical hazards can arise from such systems.
- If compensating currents are to be expected within the complete system, then a separate equipotential bonding conductor must be provided. The shield is not meant to serve as an equipotential bonding conductor.
- For encoders, provide high-frequency, low-resistance grounding (see the EMC chapter in EN 60204-01).

HEIDENHAIN

Mastering nanometer accuracy



HEIDENHAIN

DR. JOHANNES HEIDENHAIN GmbH

Dr.-Johannes-Heidenhain-Straße 5

83301 Traunreut, Germany

☎ +49 8669 31-0

☎ +49 8669 32-5061

✉ info@heidenhain.de

www.heidenhain.com



HEIDENHAIN
worldwide