

Für Funktionale Sicherheit und Mechanischen Fehlerausschluss obligatorisch  
Obligatory for functional safety and mechanical fault exclusion

Materialvorgaben nach den allgemeinen mechanischen Hinweisen  
im aktuellen Drehgeberkatalog (D349529)  
Material requirements according to "General mechanical information"  
in the current "Rotary Encoders" brochure (ID D349529)

	Kundenwelle Customer shaft	Kundenstator Mating stator
Material Material	Kein Fehlerausschluss für die Wellenanbindung von HEIDENHAIN No fault exclusion from HEIDENHAIN for the shaft connection	Stahl / Steel (H3) oder / or Aluminium / Aluminium (H2)
		Anzugsmoment Tightening torque
(H1)	M4 - 8.8	2.65 Nm ±0.1 Nm

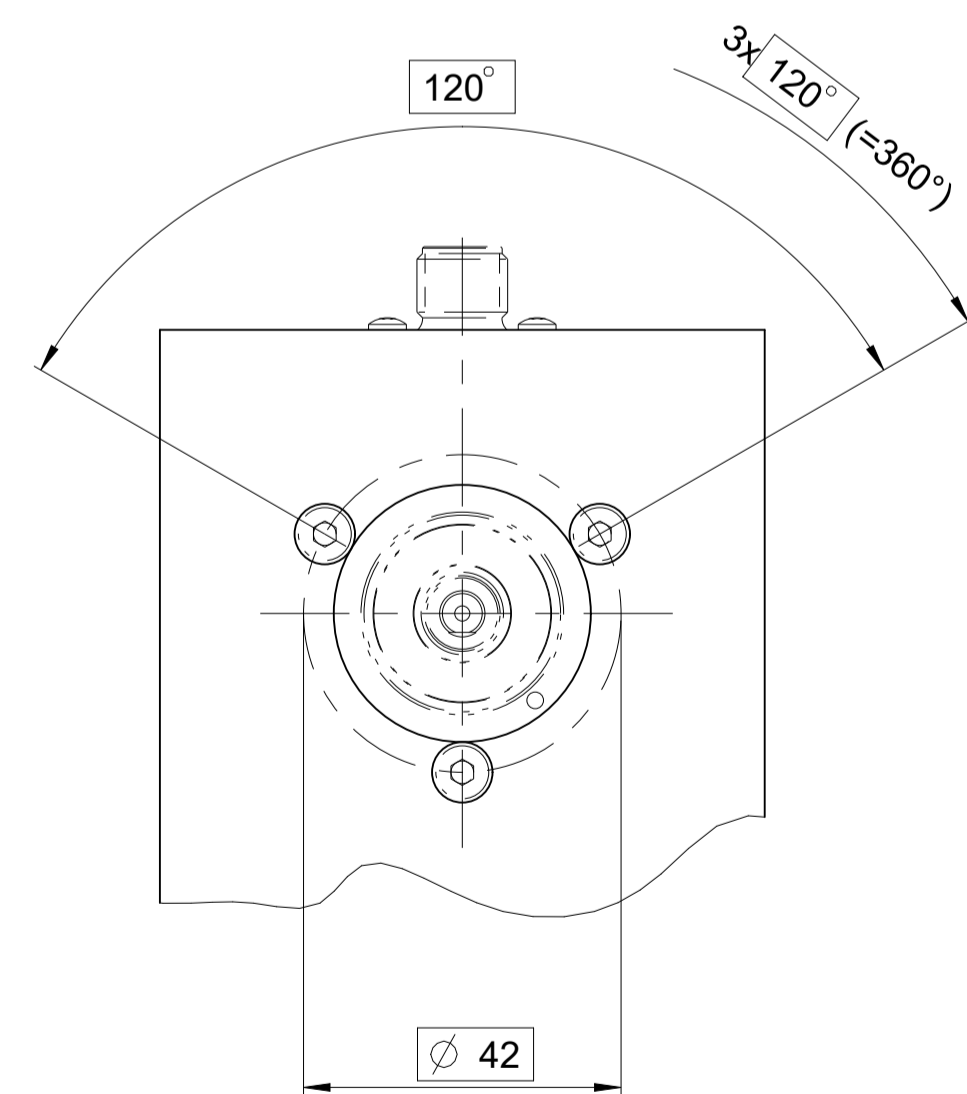
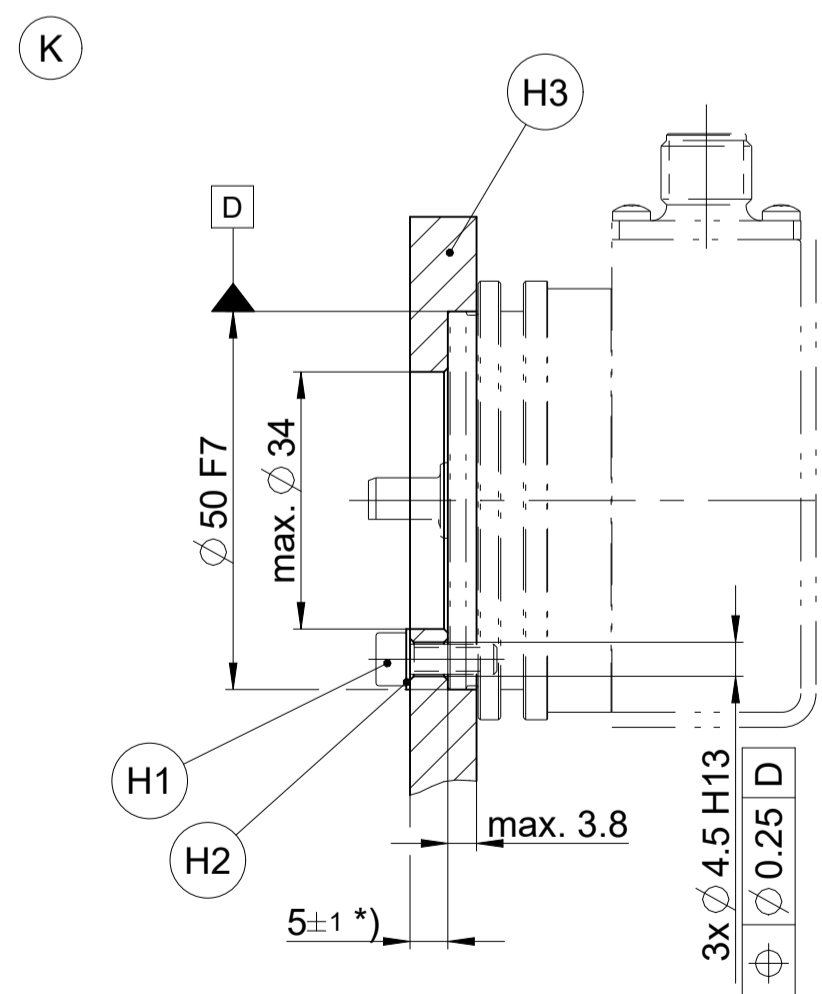

- (A) = Lagerung Geber
- (M1) = Messpunkt Arbeitstemperatur
- (M2) = Messpunkt Vibration
- (K) = Kundenseitige Anschlußmaße
- (H1) = Schrauben M4 - 8.8 mit geeigneter, mindestens mittelfester stoffschlüssiger Losdrehicherung  
Aushärtezeit der stoffschlüssigen Losdrehicherung beachten  
Anzugsmoment 2,65±0,1Nm, Mindestschraubtiefe 6mm  
Zur Fehlerausschlussberechnung wurde eine stoffschlüssige Losdrehicherung mit einer Gewindereibungszahl zwischen 0,1 und 0,16 zugrunde gelegt.
- (H2) = bei zul. Grenzflächenpressung  $p_G \leq 280\text{N/mm}^2$  Scheibe verwenden
- (H3) = \*) bei Wahl eines Materials mit einem spez. Wärmeausdehnungskoeffizienten von  $\alpha = 10 \times 10^{-6}\text{K}^{-1}$  bis  $14 \times 10^{-6}\text{K}^{-1}$  (Stahl), kann die max. Plattendicke bis zu 20mm betragen
- (H4) = Drehrichtung der Welle für steigende Positionswerte

- Rotary encoder bearing
- Measuring point for operating temperature
- Measuring point for vibration
- Required mating dimensions
- Screws: M4 - 8.8, with suitable material bonding anti-rotation lock (at least medium strength); comply with the curing time of the material bonding anti-rotation lock; tightening torque: 2.65 Nm ±0.1 Nm; minimum engagement depth of screw: 6 mm  
Fault exclusion was calculated based on a material bonding anti-rotation lock with a thread friction coefficient of between 0.1 and 0.16.
- If permissible interface pressure  $p_G < 280\text{N/mm}^2$  use washer
- \*) If a material with a coefficient of linear thermal expansion between  $\alpha = 10 \times 10^{-6}\text{K}^{-1}$  and  $14 \times 10^{-6}\text{K}^{-1}$  (steel) is chosen, the thickness can be up to 20 mm
- Direction of shaft rotation for ascending position values

92A	01C	ID number:
WELLA1	FLANA1	Change No. C198361-05
		Phase: Serie
Original drawing	Scale	Format
Dimensions in mm	1:1	A1
ROC/ROQ 4xx ROC/ROQ 4xx Anschlußmaße / Mating Dimensions		Tolerances as per ISO 8015
The reproduction, distribution and utilization of this document as well as the communication of its contents to others without express authorization is prohibited. Offenders will be held liable for the payment of damages. All rights reserved in the event of the grant of a patent, utility model or design. (ISO 18015)		General Tolerances ISO 2768-1:2008-mH ±0.2
Released	Version   Revision   Sheet   Page	
29.05.2026	D1038377-04 - A-01	1 of 1
HEIDENHAIN DR. JOHANNES HEIDENHAIN GmbH 83301 Traunreut, Germany		Document number